

# Multiprocessor OS



COMP9242 – Advanced Operating Systems  
Ihor Kuz (Kry10, UNSW) [Ihor.kuz@unsw.edu.au](mailto:Ihor.kuz@unsw.edu.au)  
2022 T2 Week 09

# Overview

## Multiprocessor OS (Background and Review)

- How does it work? (Background)
- Scalability (Review)

## Multiprocessor Hardware

- Contemporary systems (Intel, AMD, ARM, Oracle/Sun)
- Experimental (Intel, MS, Polaris)

## OS Design for Multiprocessors

- Guidelines
- Design approaches
  - Divide and Conquer (Disco, Tesselation)
  - Reduce Sharing (K42, Corey, Linux, FlexSC, scalable commutativity)
  - No Sharing (Barrelfish, fos)

# Multiprocessor OS

# Uniprocessor OS

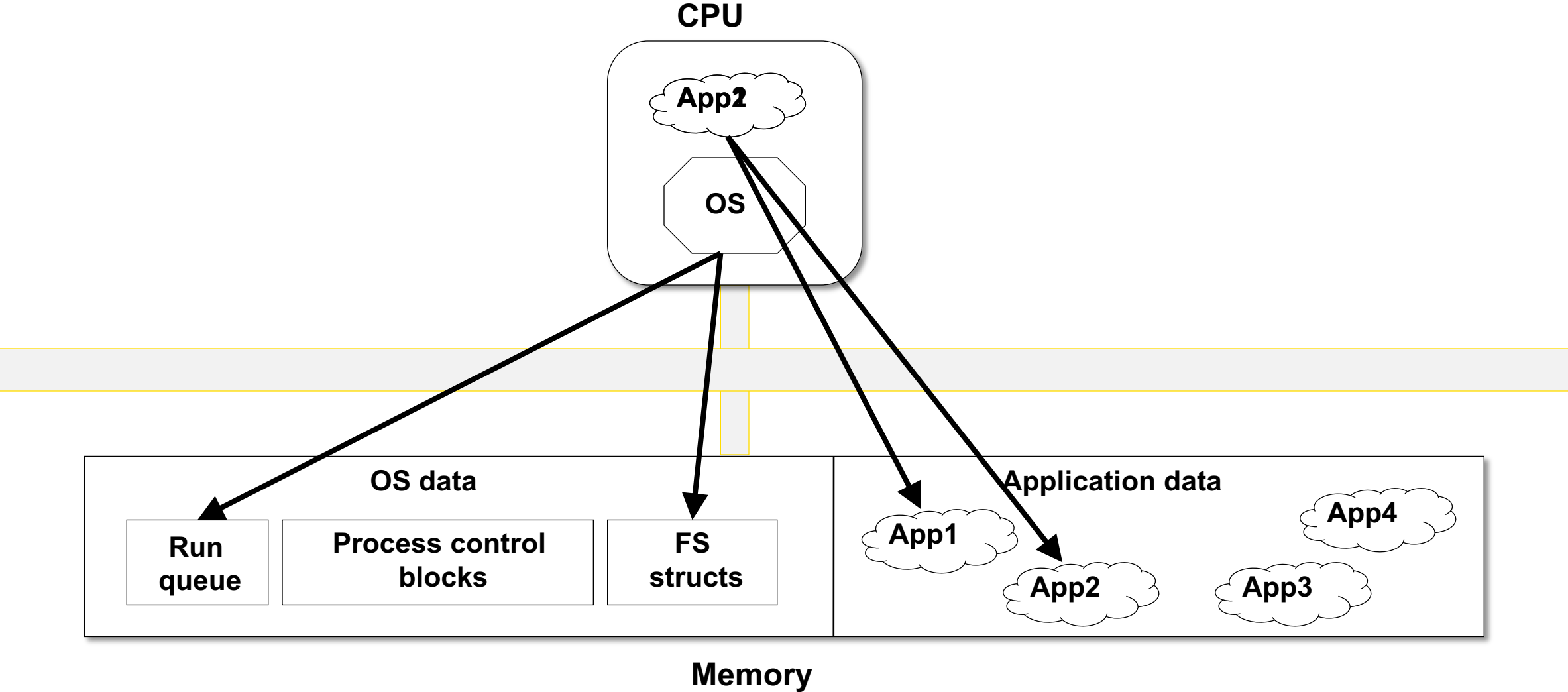

# Multiprocessor OS

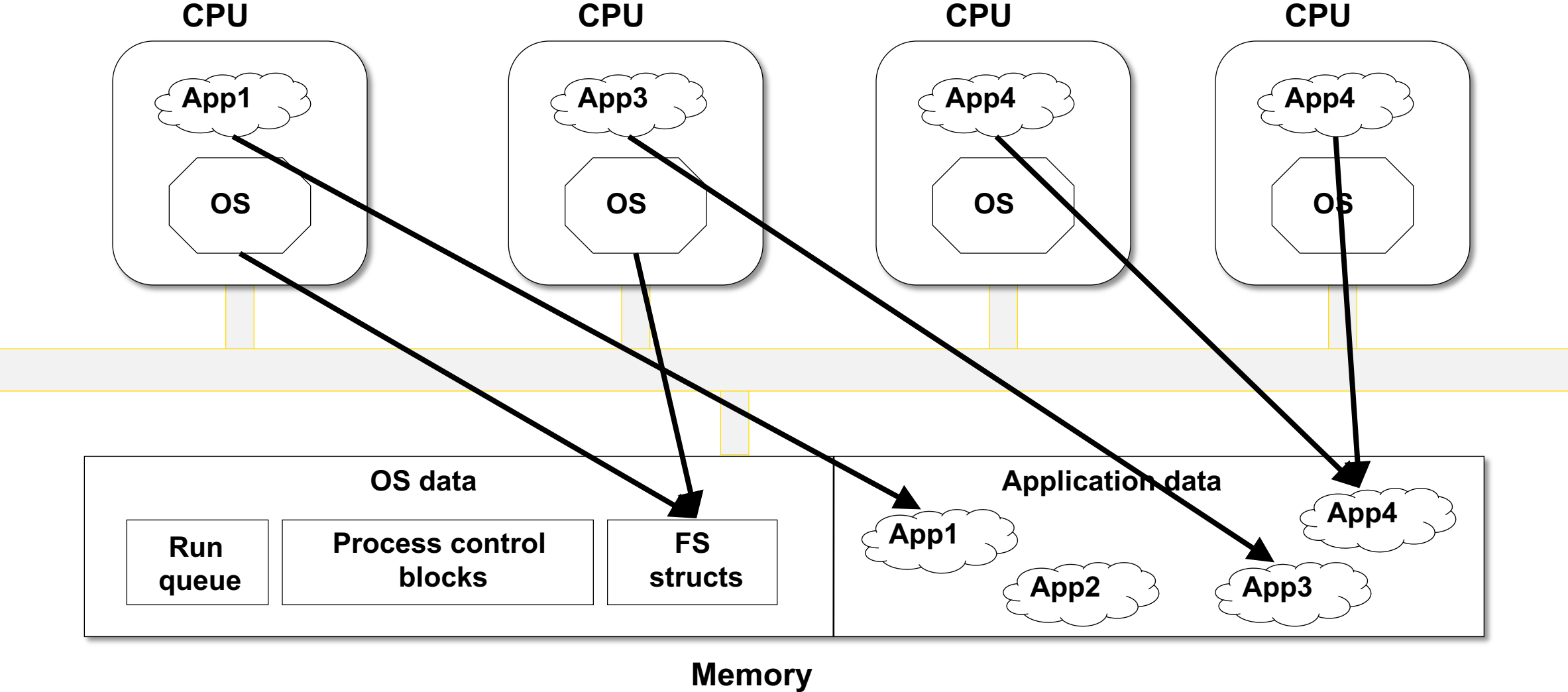

# Multiprocessor OS

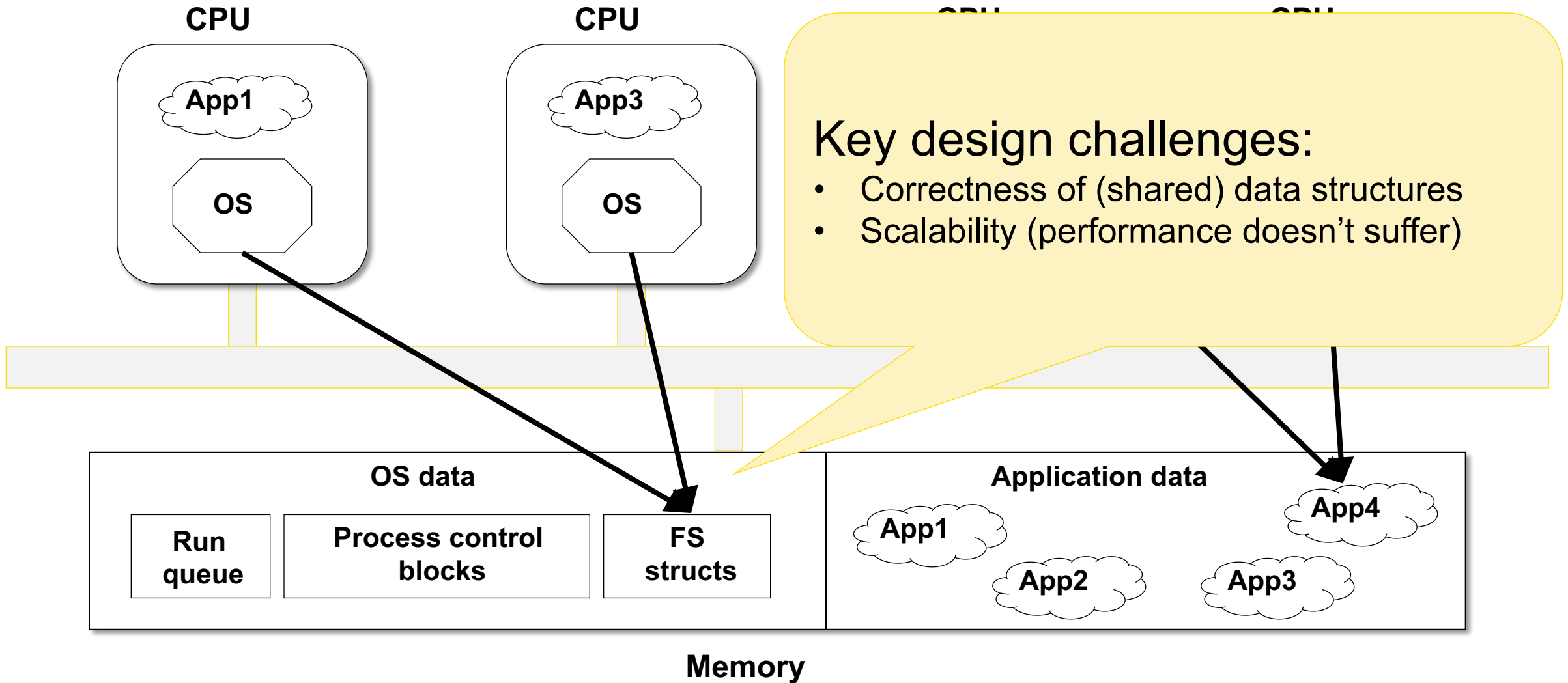

# Correctness of Shared Data

## Concurrency control

- Locks
- Semaphores
- Transactions
- Lock-free data structures

## We know how to do this:

- In the application
- In the OS

# Scalability

Speedup as more processors added

**Ideal**

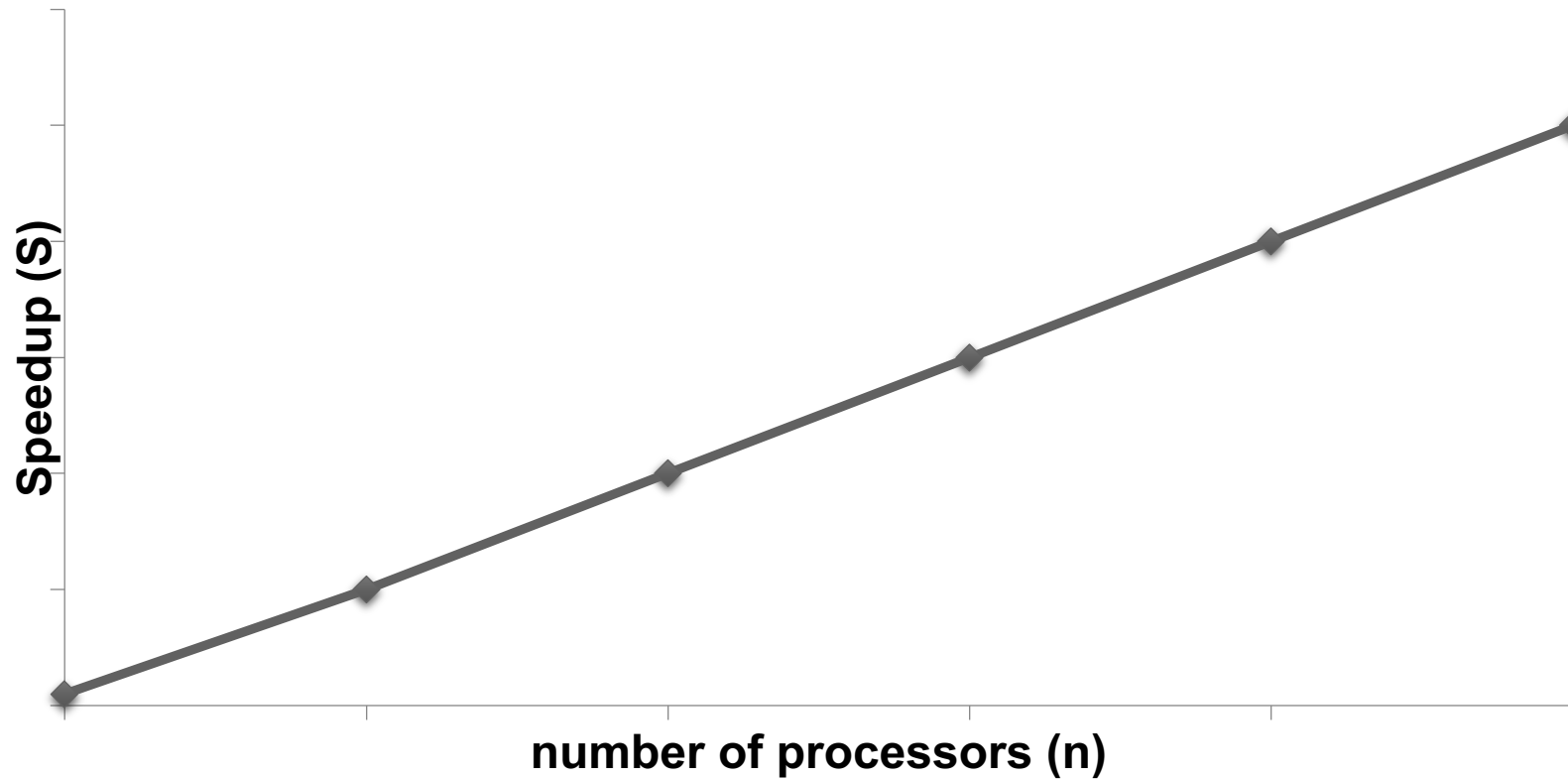

$$S(N) = \frac{T_1}{T_N}$$



# Scalability

Speedup as more processors added  
**Reality**

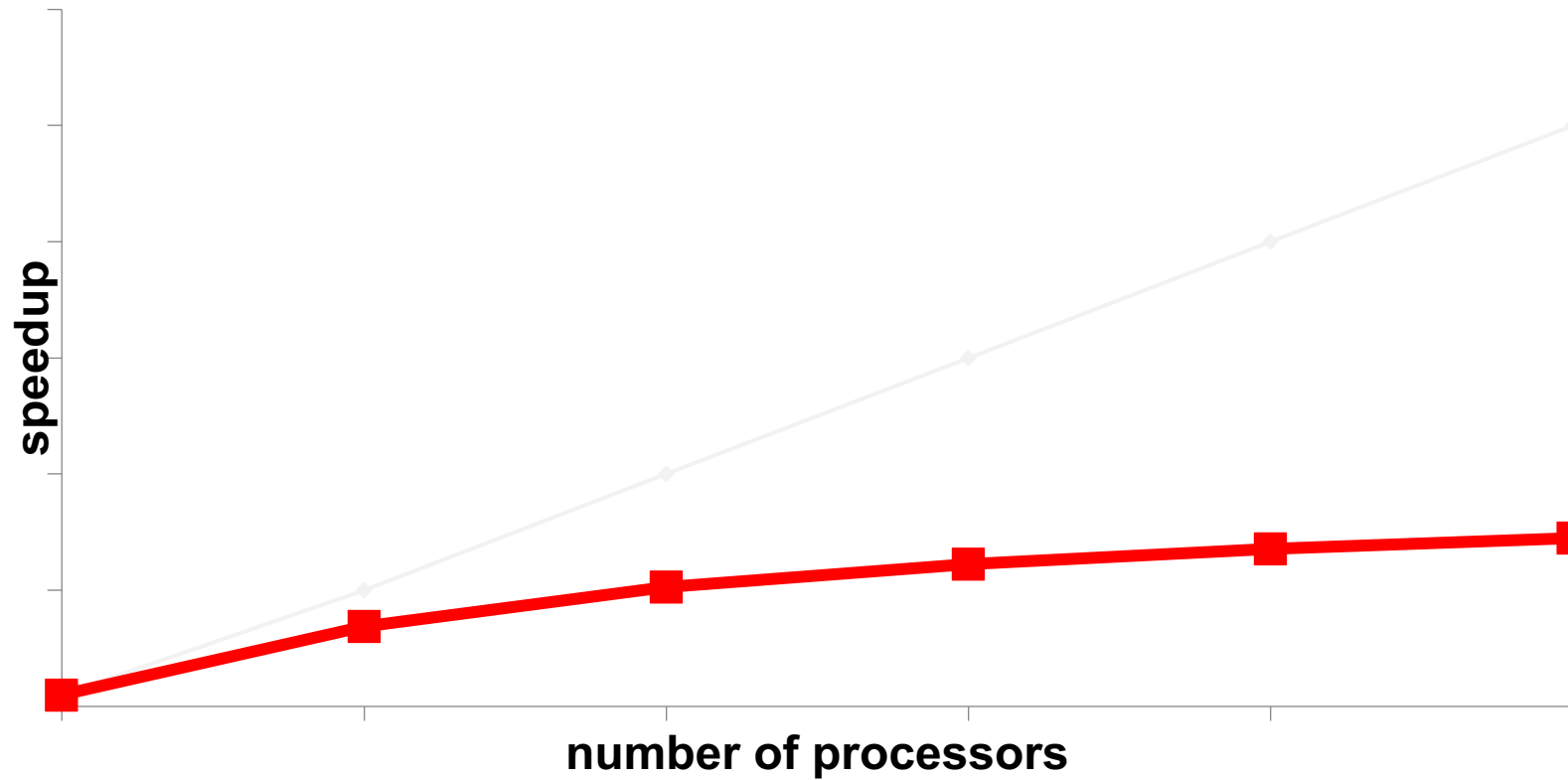

$$S(N) = \frac{T_1}{T_N}$$

# Scalability and Serialisation

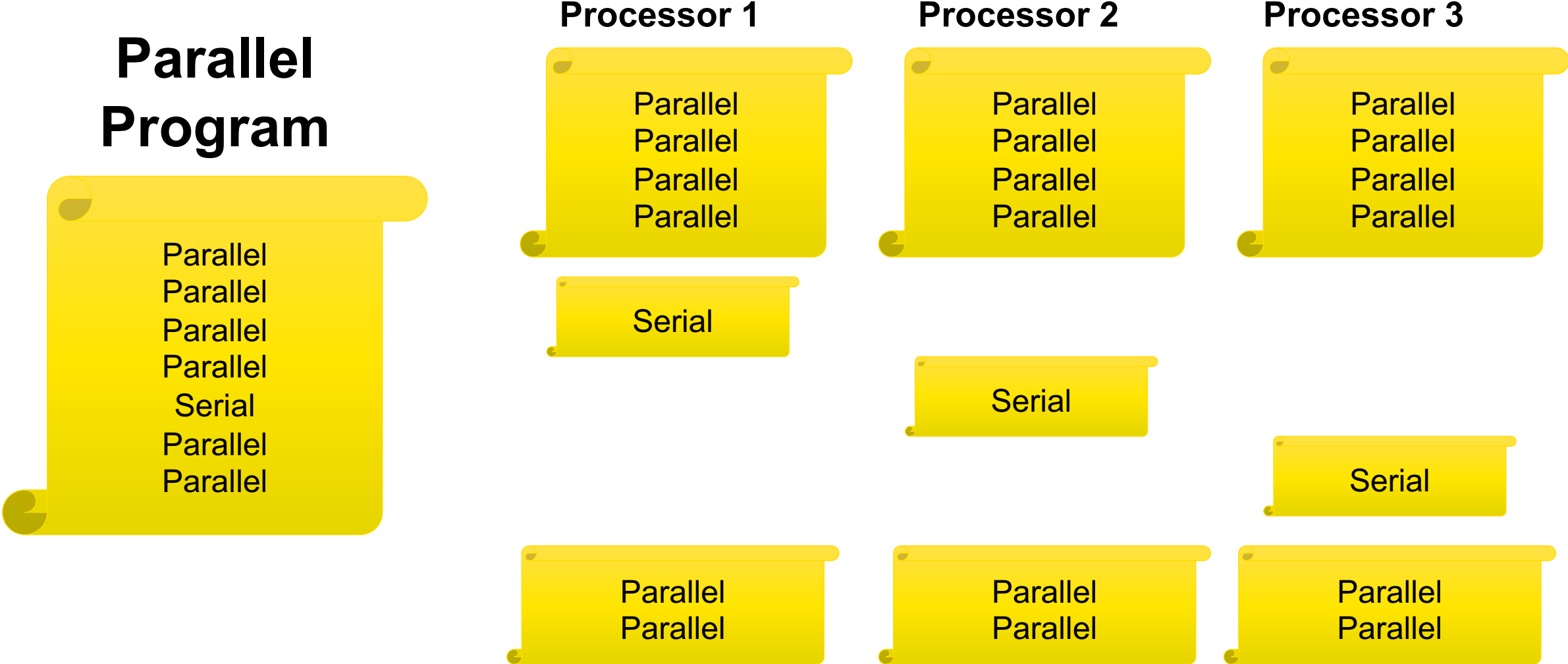

# Scalability and Serialisation

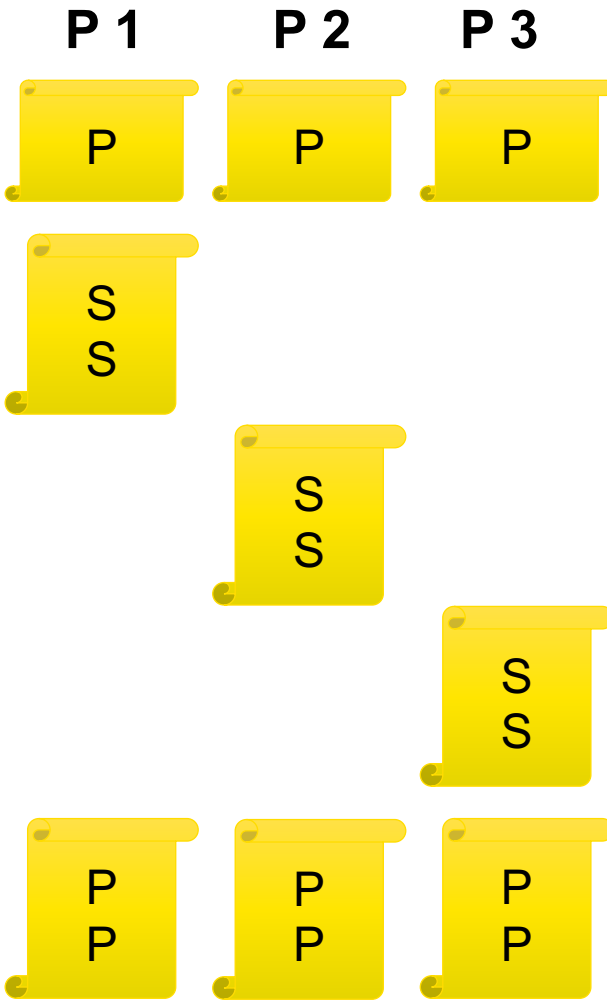
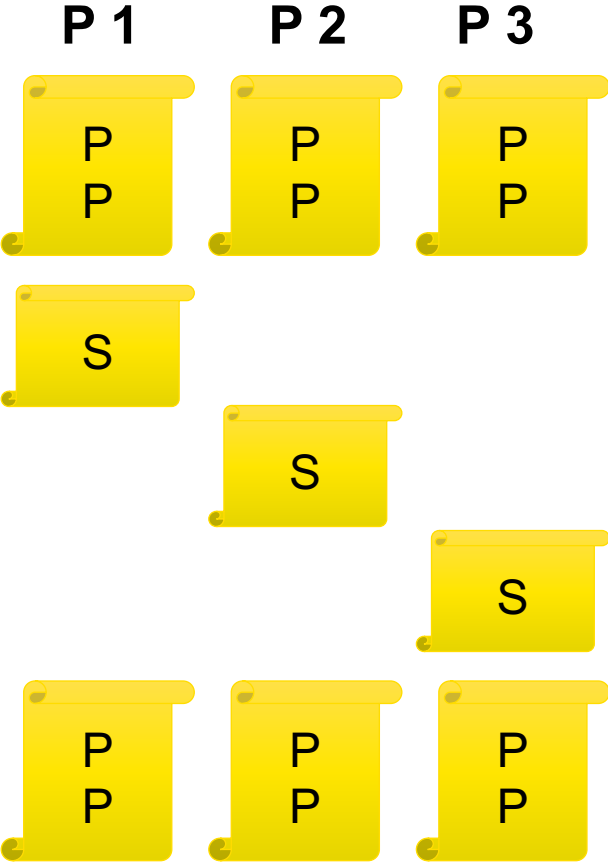
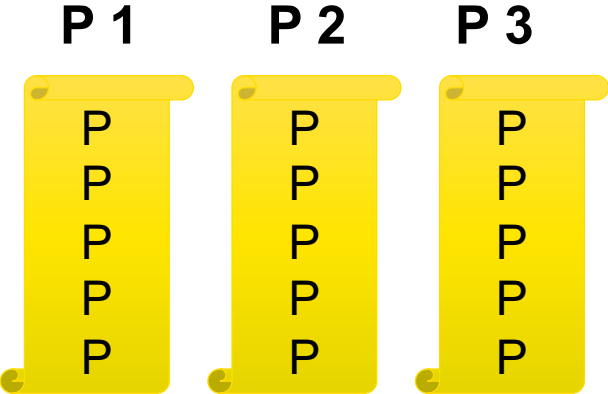

# Scalability and Serialisation

## Remember Amdahl's law

- Serial (non-parallel) portion: when application not running on all cores
- Serialisation prevents scalability

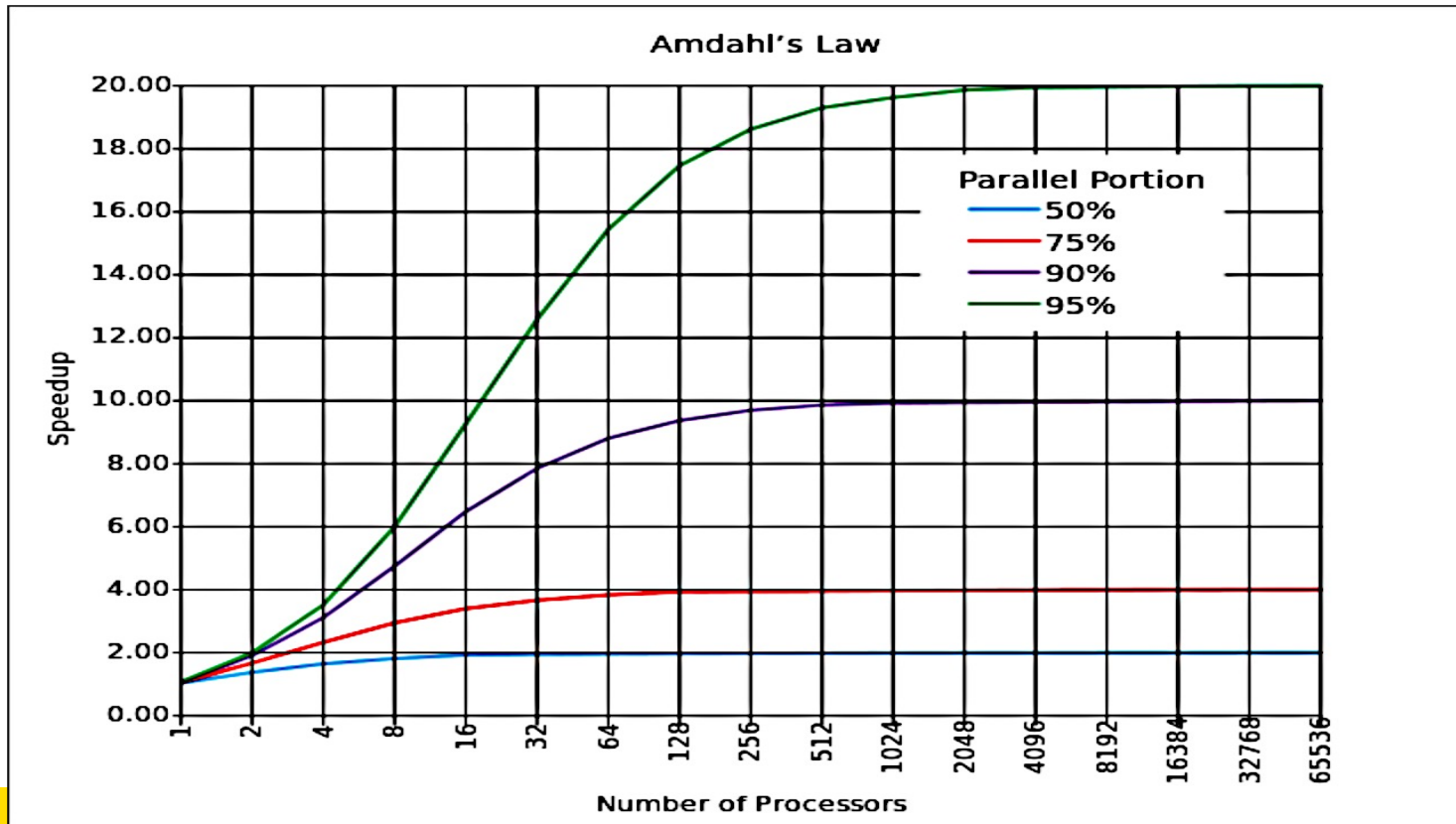

$$T_1 = 1 = (1 - P) + P$$

$$T_N = (1 - P) + \frac{P}{N}$$

$$S(N) = \frac{T_1}{T_N} = \frac{1}{(1 - P) + \frac{P}{N}}$$

$$S(\infty) \rightarrow \frac{1}{(1 - P)}$$

# Serialisation

## Where does serialisation show up?

- Application (e.g. access shared app data)
- OS (e.g. performing syscall for app) **How much time is spent in OS?**

## Sources of Serialisation

### Locking (explicit serialisation)

- Waiting for a lock → **stalls self**
- Lock implementation:
  - Atomic operations lock bus → **stalls everyone waiting for memory**
  - Cache coherence traffic loads bus → **stalls others waiting for memory**

### Memory access (implicit)

- Relatively high latency to memory → **stalls self**

### Cache (implicit)

- **Processor stalled** while cache line is fetched or invalidated
- Affected by latency of interconnect
- Performance depends on data size (cache lines) and contention (number of cores)

# More Cache-related Serialisation

## False sharing

- Unrelated data structs share the same cache line
- Accessed from different processors
- Cache coherence traffic and delay

## Cache line bouncing

- Shared R/W on many processors
- E.g: bouncing due to locks: each processor spinning on a lock brings it into its own cache
- Cache coherence traffic and delay

## Cache misses

- Potentially direct memory access → stalls self
- When does cache miss occur?
  - Application accesses data for the first time, Application runs on new core
  - Cached memory has been evicted
    - Cache footprint too big, another app ran, OS ran

# Multiprocessor Hardware

# Multi-What?

## Terminology:

- core, die (chip), package (module, processor, CPU)

## Multiprocessor, SMP

- >1 separate processors, connected by off-processor interconnect

## Multithread, SMT

- >1 hardware threads in a single processing core

## Multicore, CMP

- >1 processing cores in a single die, connected by on-die interconnect

## Multicore + Multiprocessor

- >1 multicore dies in a package (multi-chip module), on-processor interconnect
- >1 multicore processors, off-processor interconnect

## Manycore

- Lots (>100) of cores

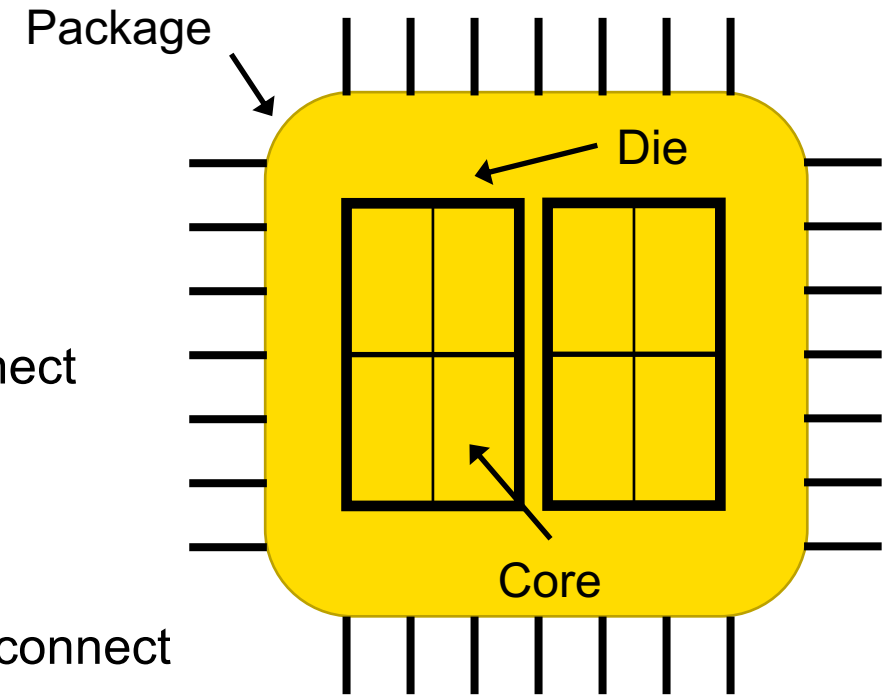



# Contemporary Multiprocessor Hardware

## Intel:

- Nehalem, Westmere: 10 core, QPI
- Sandy Bridge, Ivy Bridge: 5 core, ring bus, integrated GPU, L3, IO
- Haswell (Broadwell): 18+ core, ring bus, transactional memory, slices (EP)
- Skylake (SP): mesh architecture

## AMD:

- K10 (Opteron: Barcelona, Magny Cours): 12 core, Hypertransport
- Bulldozer, Piledriver, Steamroller (Opteron, FX)
  - 16 core, Clustered Multithread: module with 2 integer cores
- Zen: on die NUMA: CPU Complex (CCX) (4 core, private L3)
- Zen 2: chiplets (2xCCX) chiplets, IO die (incl mem controller)

## Oracle (Sun) UltraSparc T1,T2,T3,T4,T5 (Niagara), M5,M7

- T5: 16 cores, 8 threads/core (2 simultaneous), crossbar, 8 sockets,
- M8: 32 core, 8 threads, on chip network, 8 sockets, 5GHz

## ARM Cortex A9, A15 MPCore, big.LITTLE, DynamIQ

- 4 -8 cores, big.LITTLE: A7 + A15, dynamIQ: A75 + A55

# Experimental/Non-mainstream Multiprocessor Hardware

## Microsoft Beehive

- Ring bus, no cache coherence

## Tilera (now Mellanox) Tile64, Tile-Gx

- 100 cores, mesh network

## Intel Polaris

- 80 cores, mesh network

## Intel SCC

- 48 cores, mesh network, no cache coherency

## Intel MIC (Multi Integrated Core)

- Knight's Corner/Landing - Xeon Phi
- 60+ cores, ring bus/mesh

# Interesting Properties of Multiprocessors

## Scale and Structure

- How many cores and processors are there
- What kinds of cores and processors are there (homogeneous vs heterogeneous)

## Memory Locality

- Where is the memory

## Caches

- What is the cache architecture

## Interconnect

- How are the cores and processors connected
- Access to IO, etc.

## Interprocessor Communication

- How do cores and processors send messages to each other

# Scale and Structure

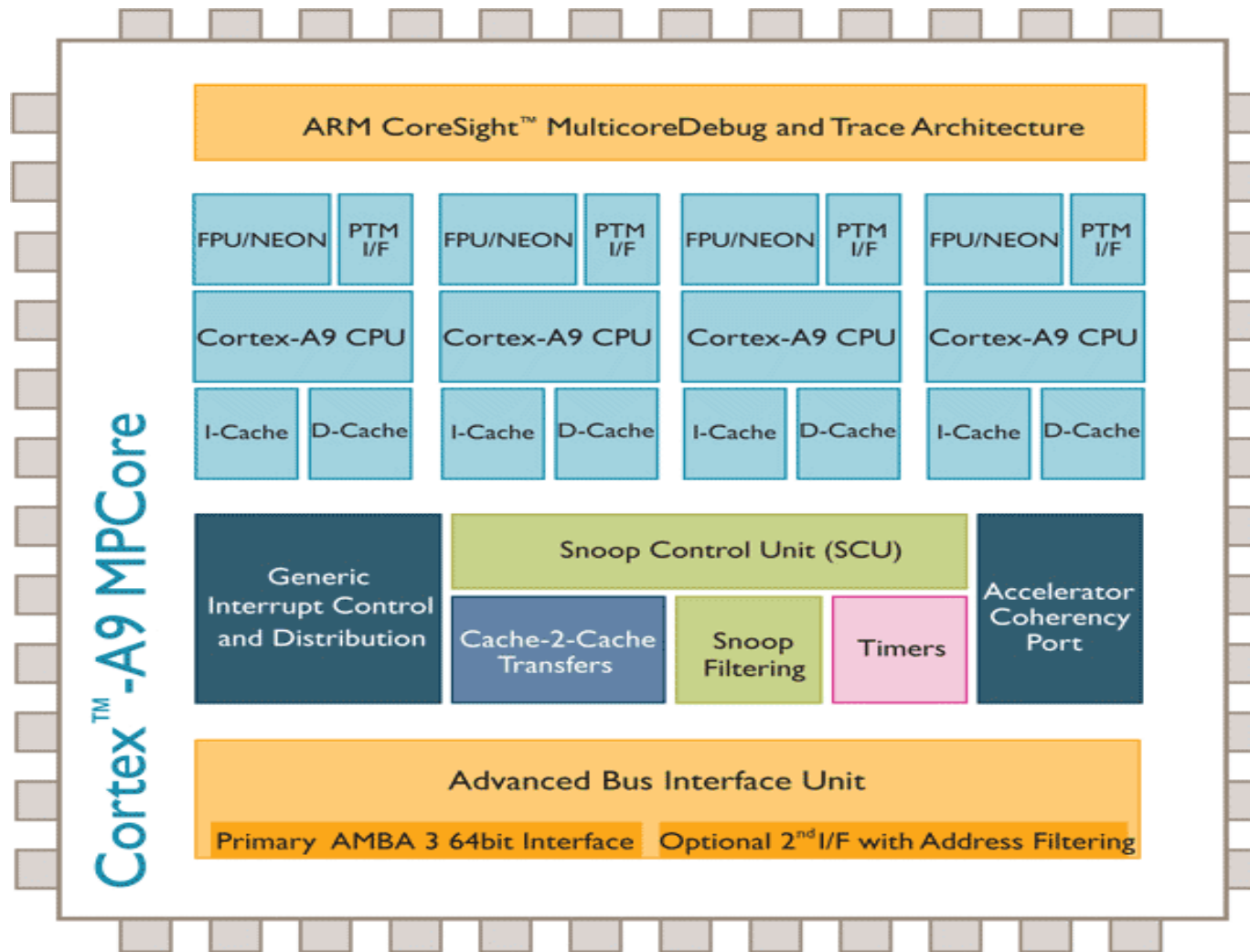

## ARM Cortex A9 MPCore

- basic structure
- single die
- homogeneous cores

# Scale and Structure

## Intel Nehalem – multiprocessor & multicore

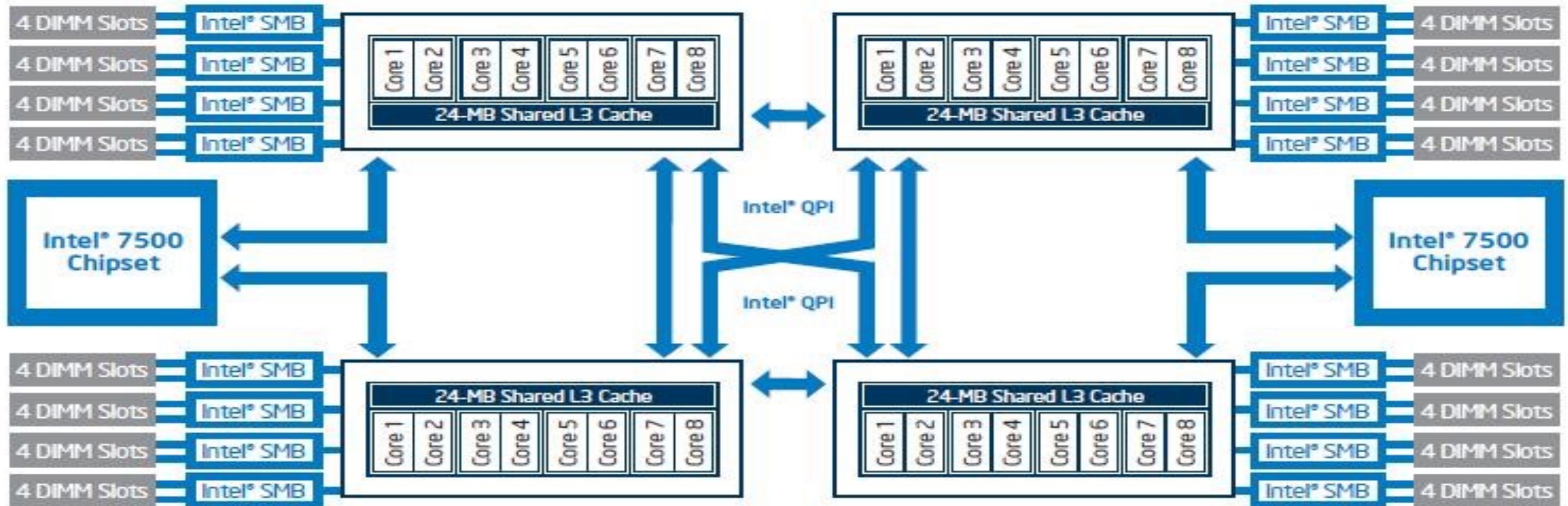

# Scale and Structure

Tilera Tile64, Intel Polaris: manycore – lots of core

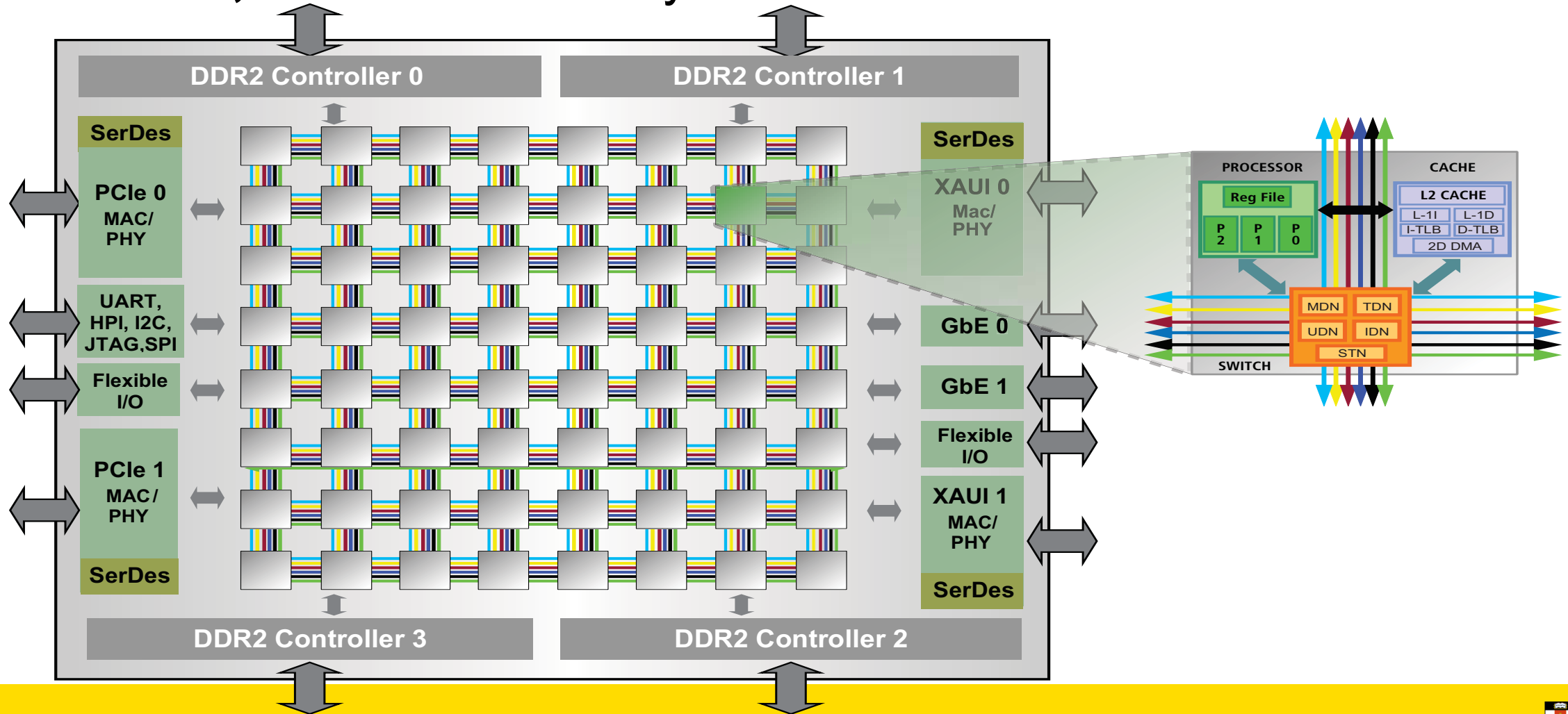

# Scale and Structure

## ARM big.LITTLE

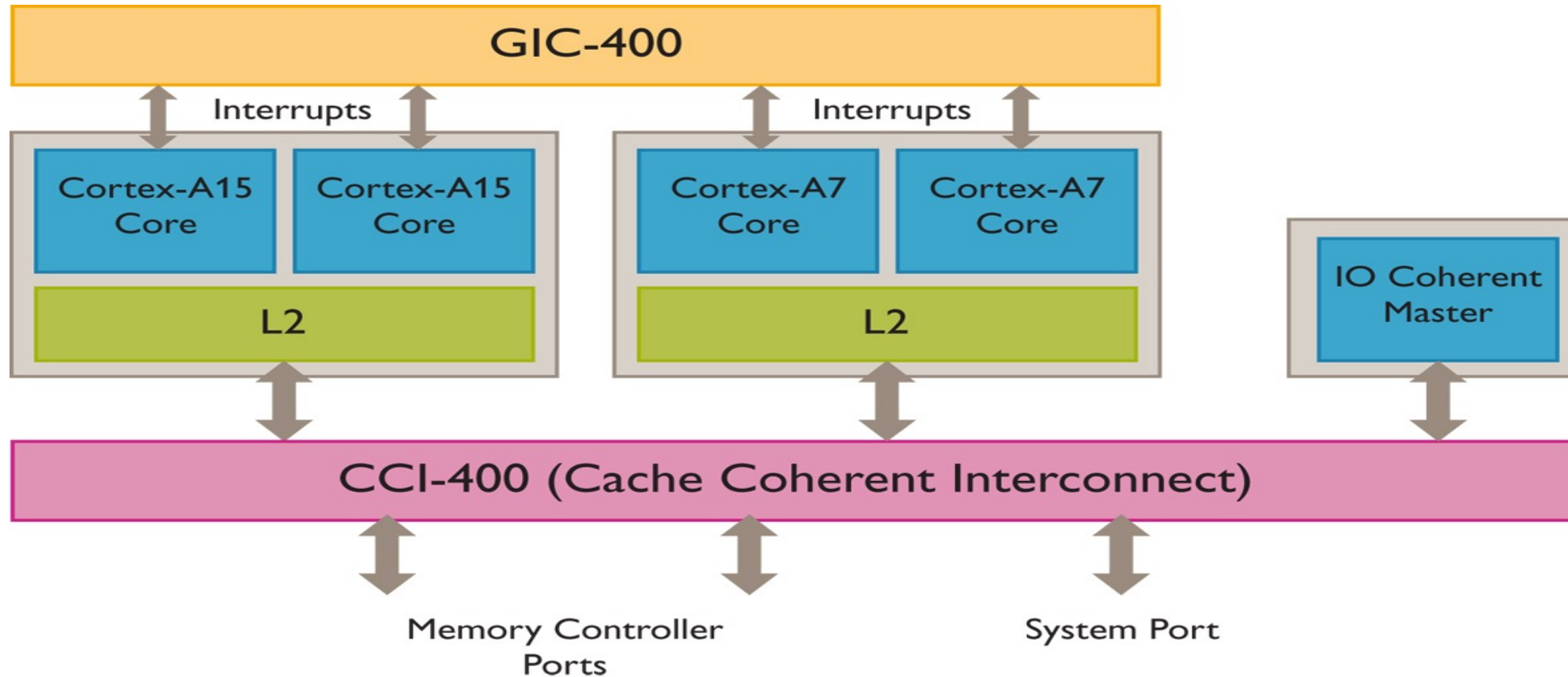

From [http://www.arm.com/images/Fig\\_1\\_Cortex-A15\\_CCI\\_Cortex-A7\\_System.jpg](http://www.arm.com/images/Fig_1_Cortex-A15_CCI_Cortex-A7_System.jpg)

# Scale and Structure

Conventional  
big.LITTLE

DynamiQ  
big.LITTLE



Quad  
Cortex-A53



1b+2L



1b+3L



Octa  
Cortex-A53



1b+4L



1b+7L

From <https://developer.arm.com/-/media/developer/Other%20Images/dynamiq-improvements-over-big-little.png>



# Scale and Structure

## NVIDIA Parker (Tegra X2) SOC

- Heterogeneity
- Application CPUs
- GPUs
- Management CPUs

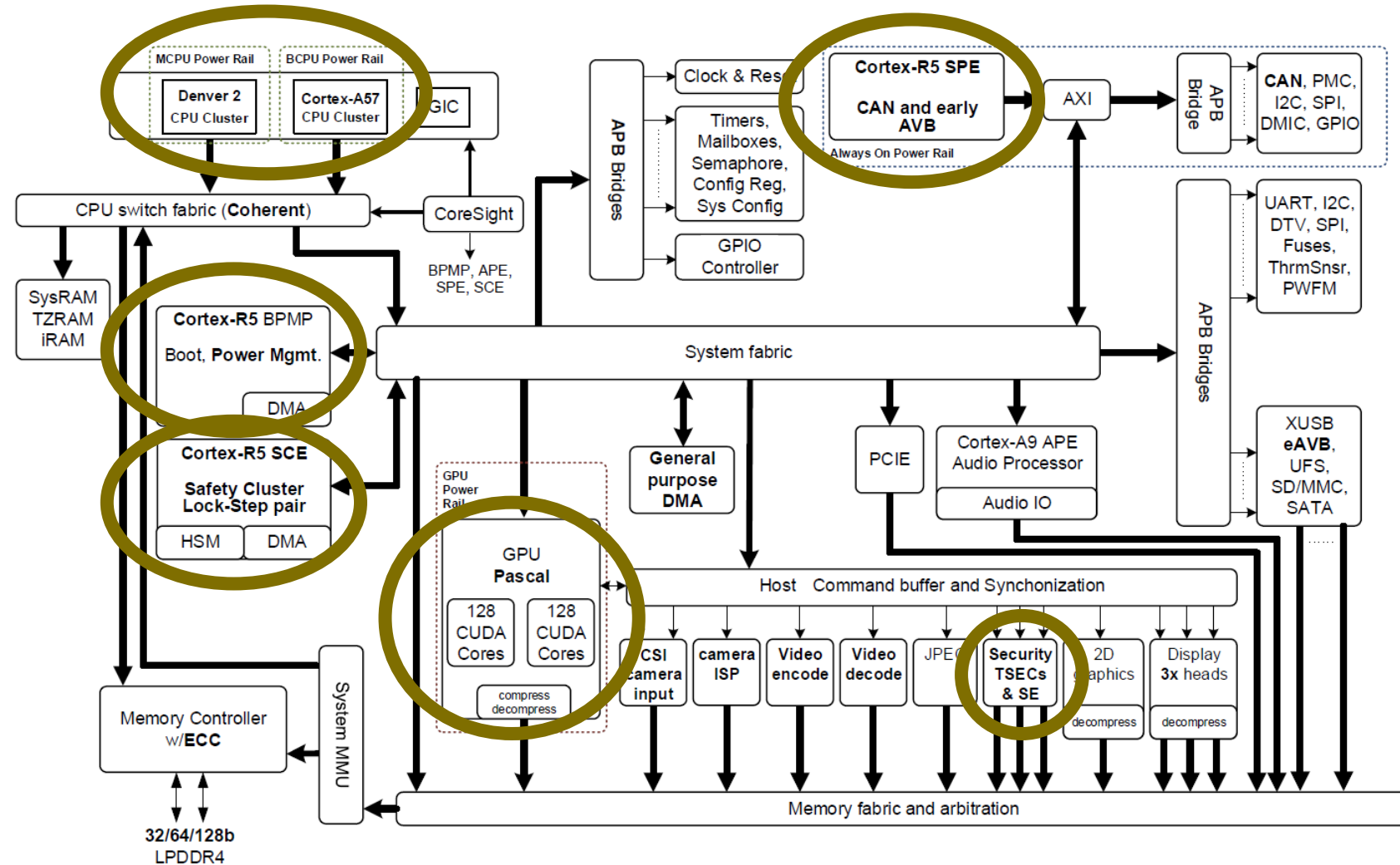

# Memory Locality

## NUMA (Non-Uniform Memory Access)

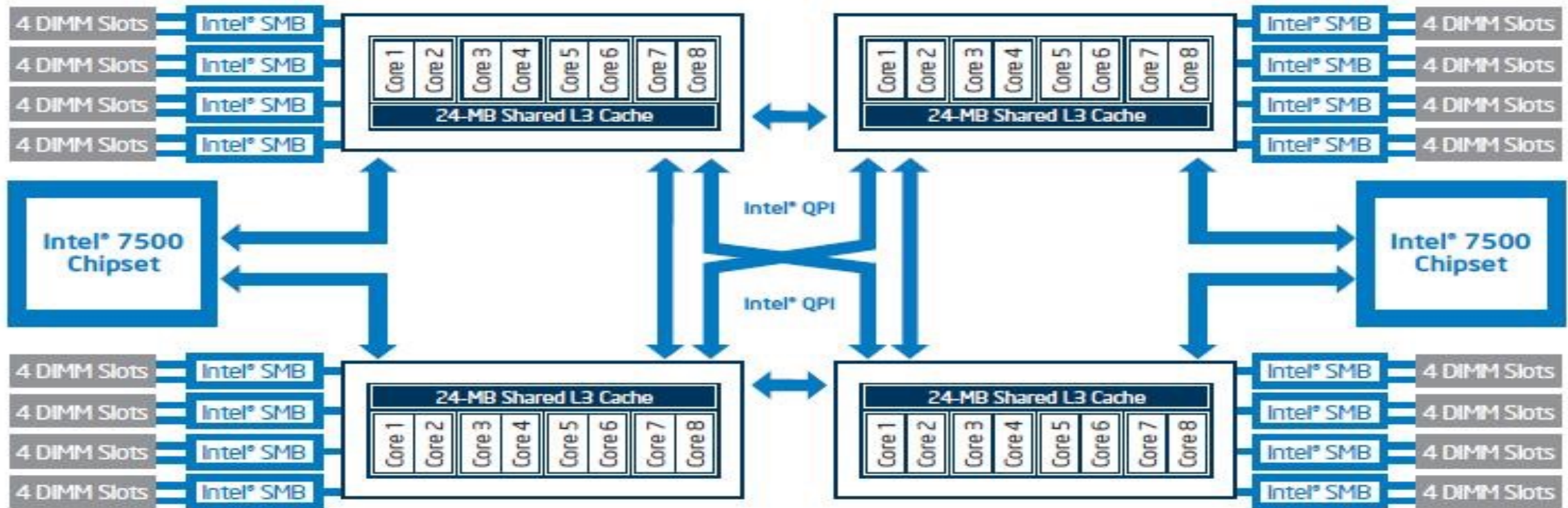

# Cache

## Hierarchy

- L1, L2, L3, ...

## Sharing

- Private – per core
- Shared – all/some cores
- Partitioned – distributed and shared

## Coherence

- No inconsistent values in caches
- At same level, at different levels
- Snooping, directory-based

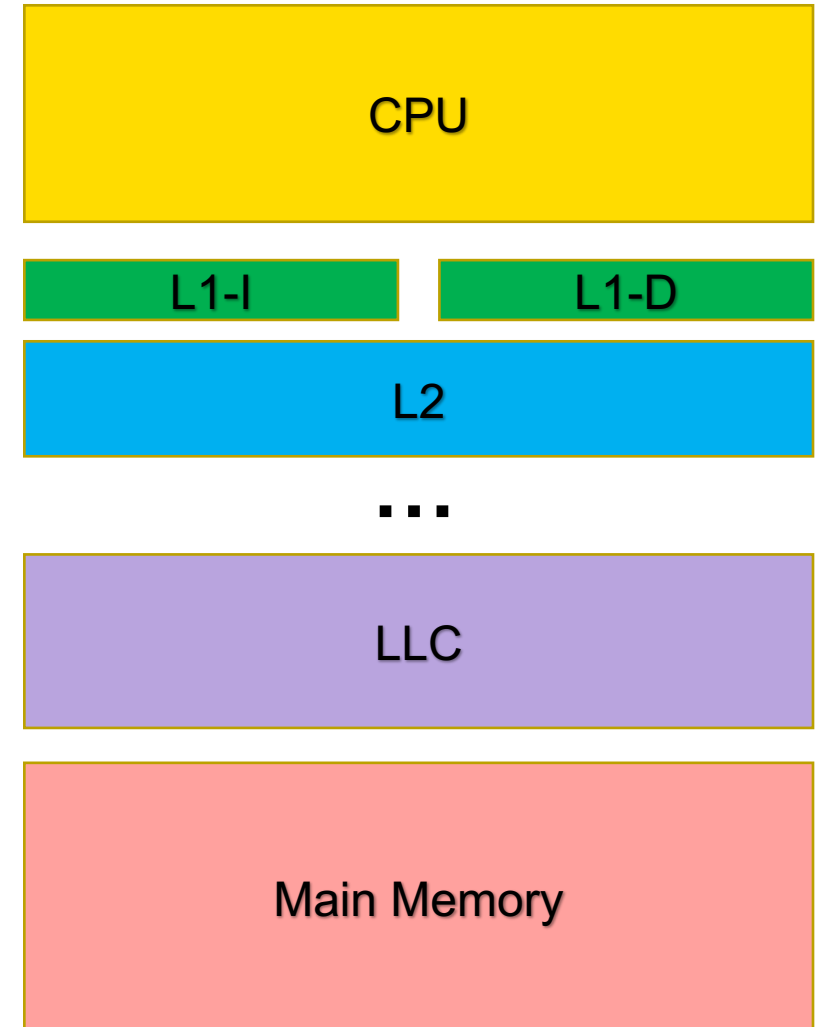

# Cache

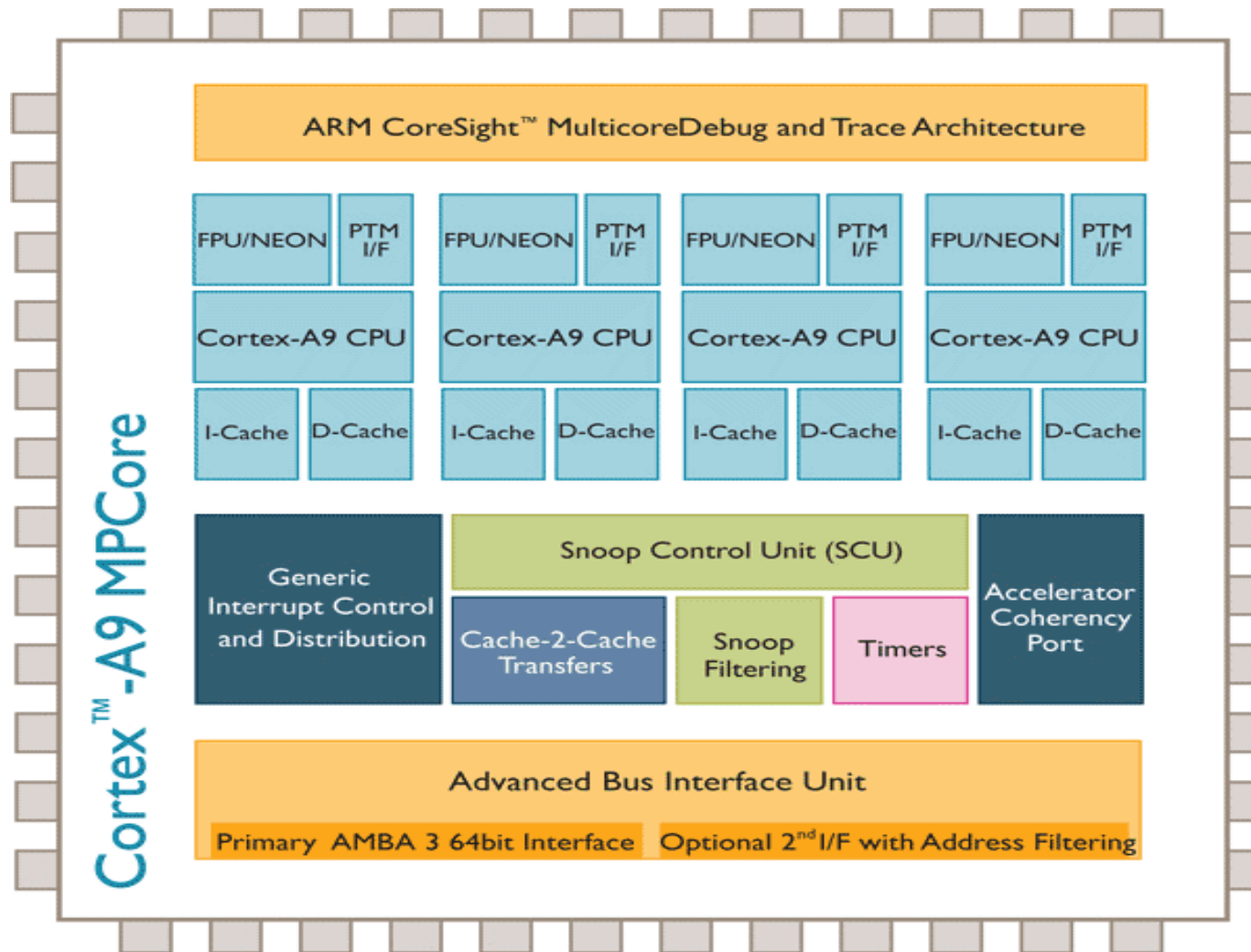

## ARM Cortex A9 MPCore

- L1 – private, split, coherent, optimised MESI
- Optional L2 – shared
- DMA cache coherent with L1 (ACP)

# Cache

Core: L1, L2. Socket: L3. Cache coherent between sockets

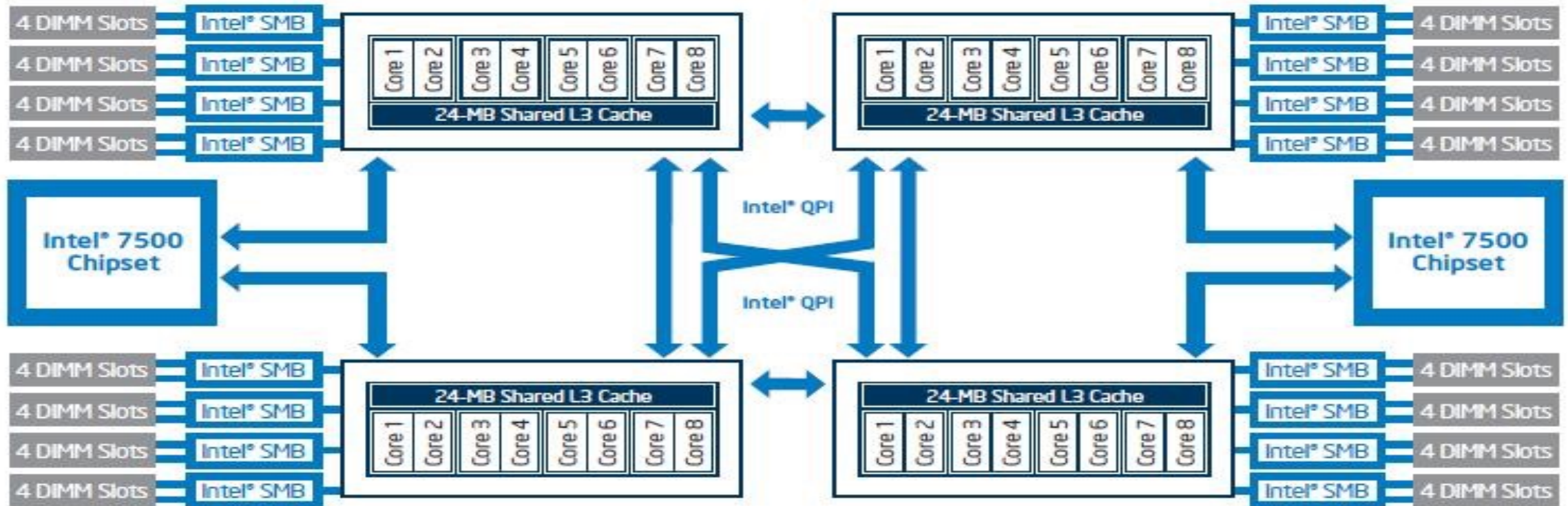

# Cache

## Oracle Sparc T2 (Niagara 2)

- private L1
- partitioned L2
- all cores equal access to L2s

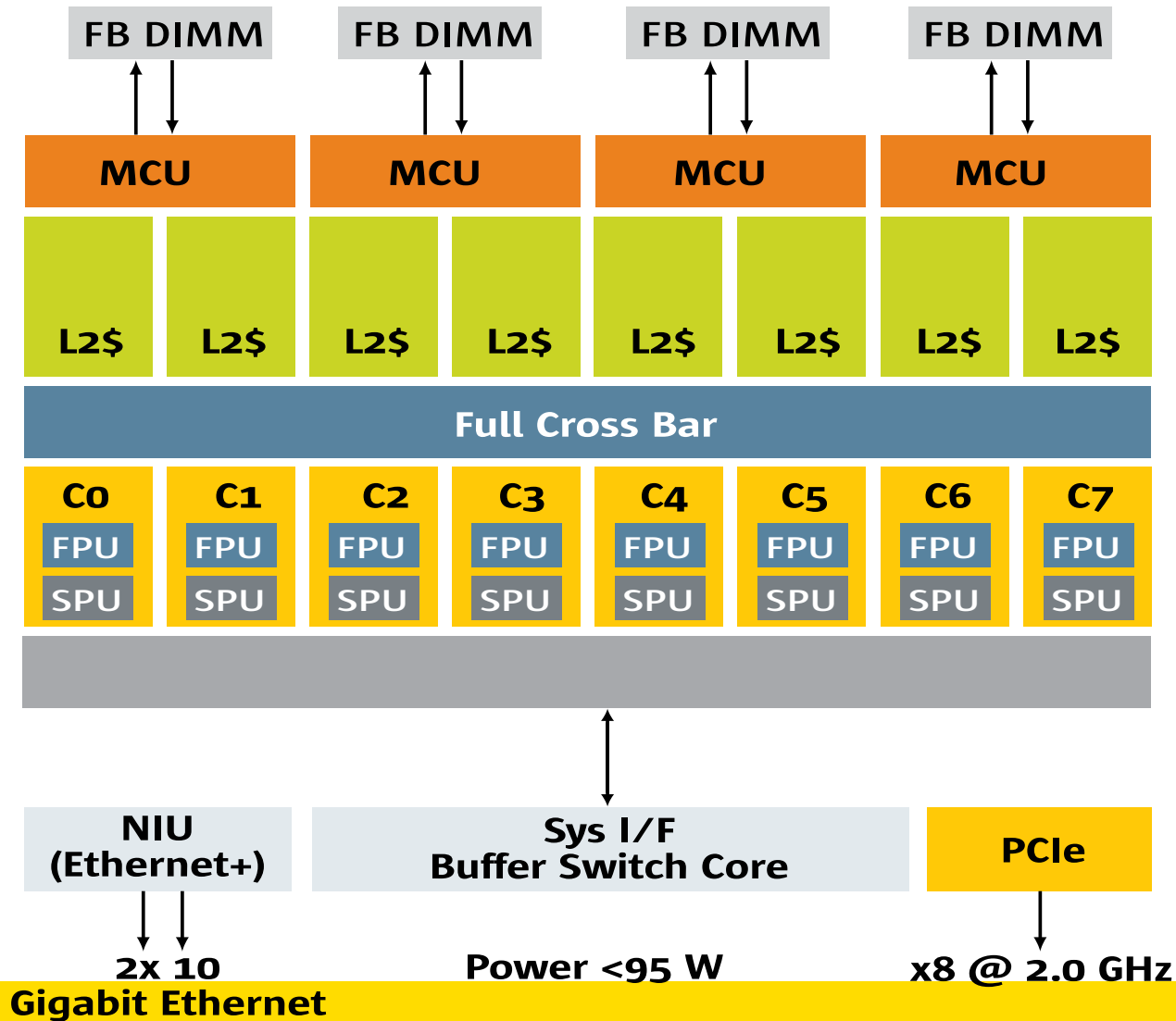

# Cache

Intel MIC (Multi Integrated Core) (Knight's Corner/Landing - Xeon Phi)

- Private L2
  - Tag Directory – info about addresses in other L2s
  - Send messages to other cores to access their L2

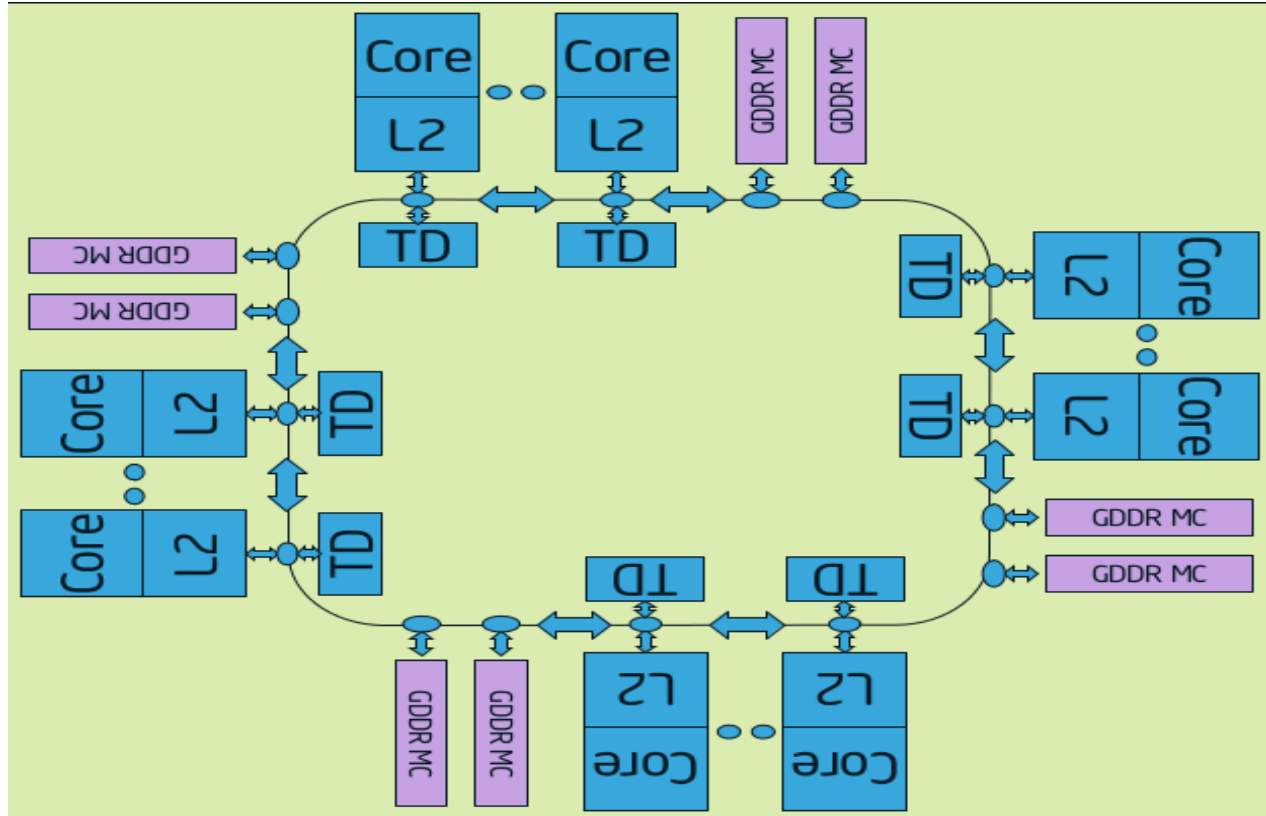

# Cache

Intel SCC – no hardware cache coherence

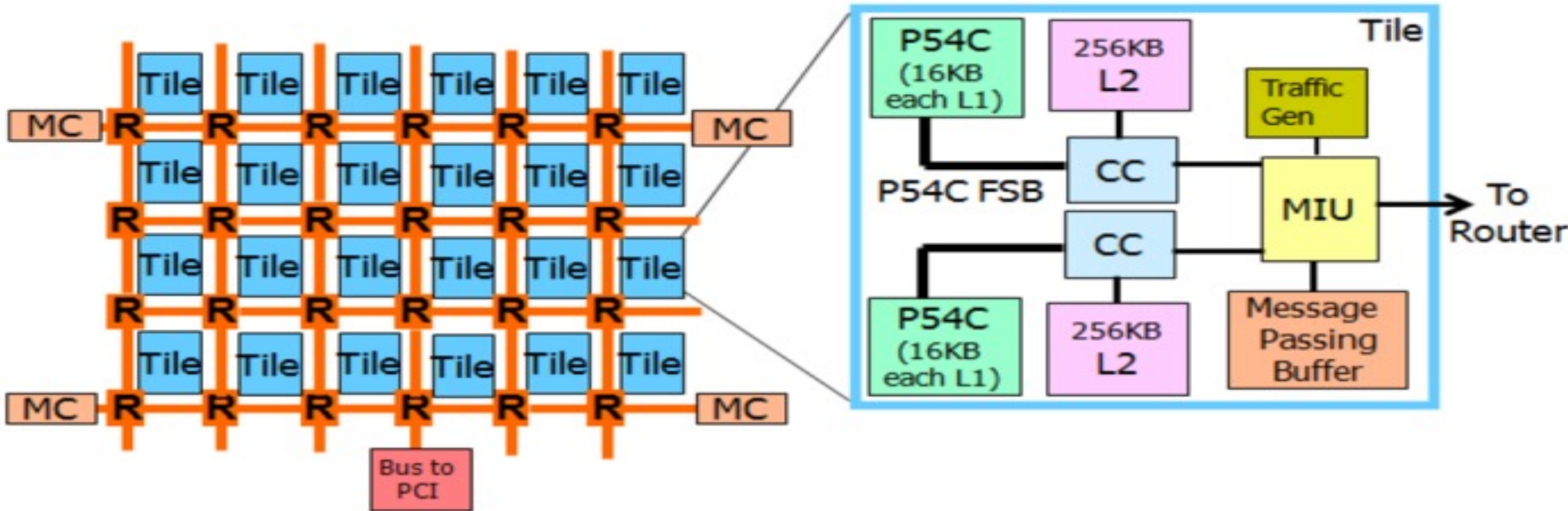



# Interconnect

## Oracle Sparc T2

- Crossbar switch between cores and L2
- Cores have independent access to L2

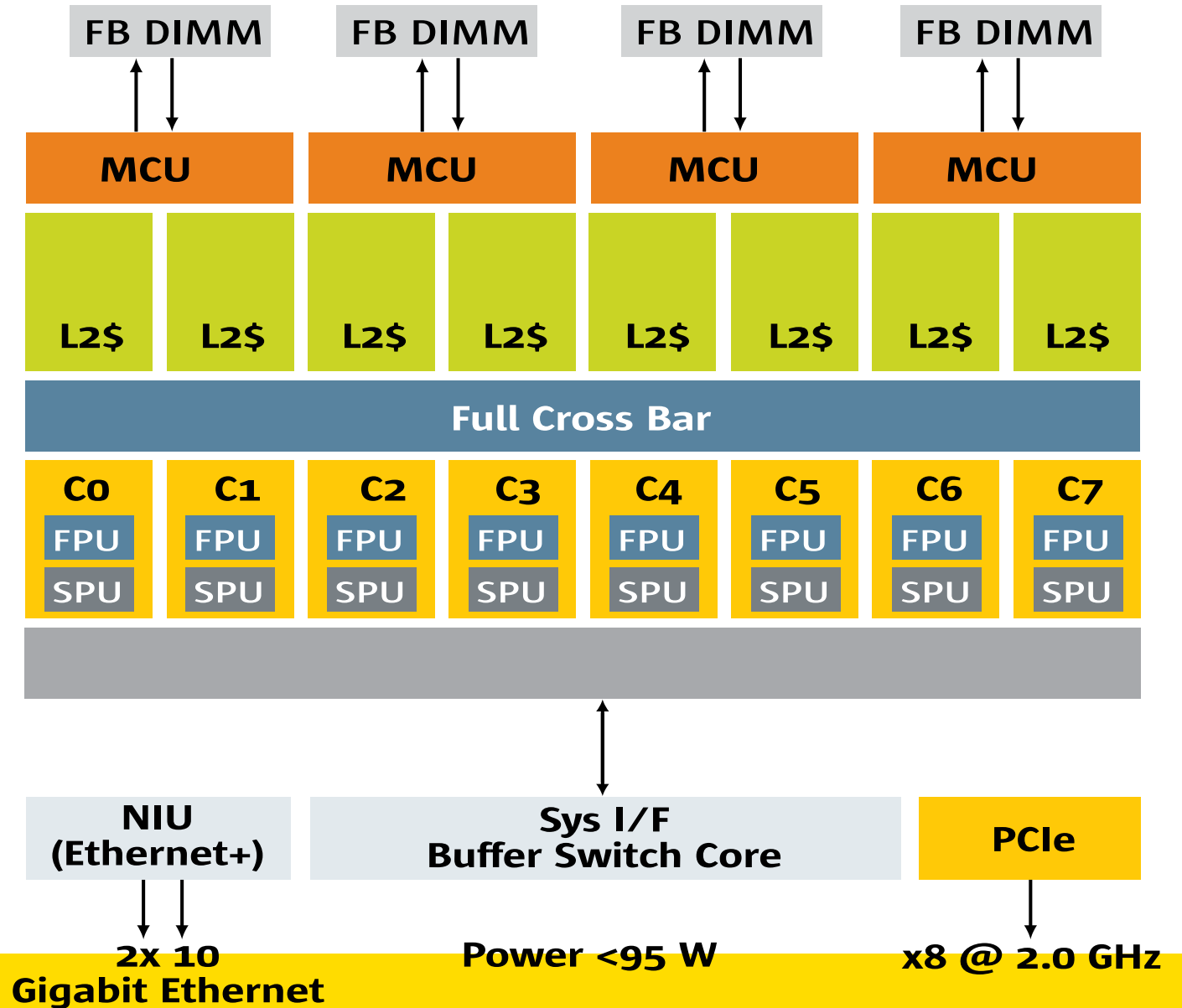

# Interconnect

## AMD Barcelona

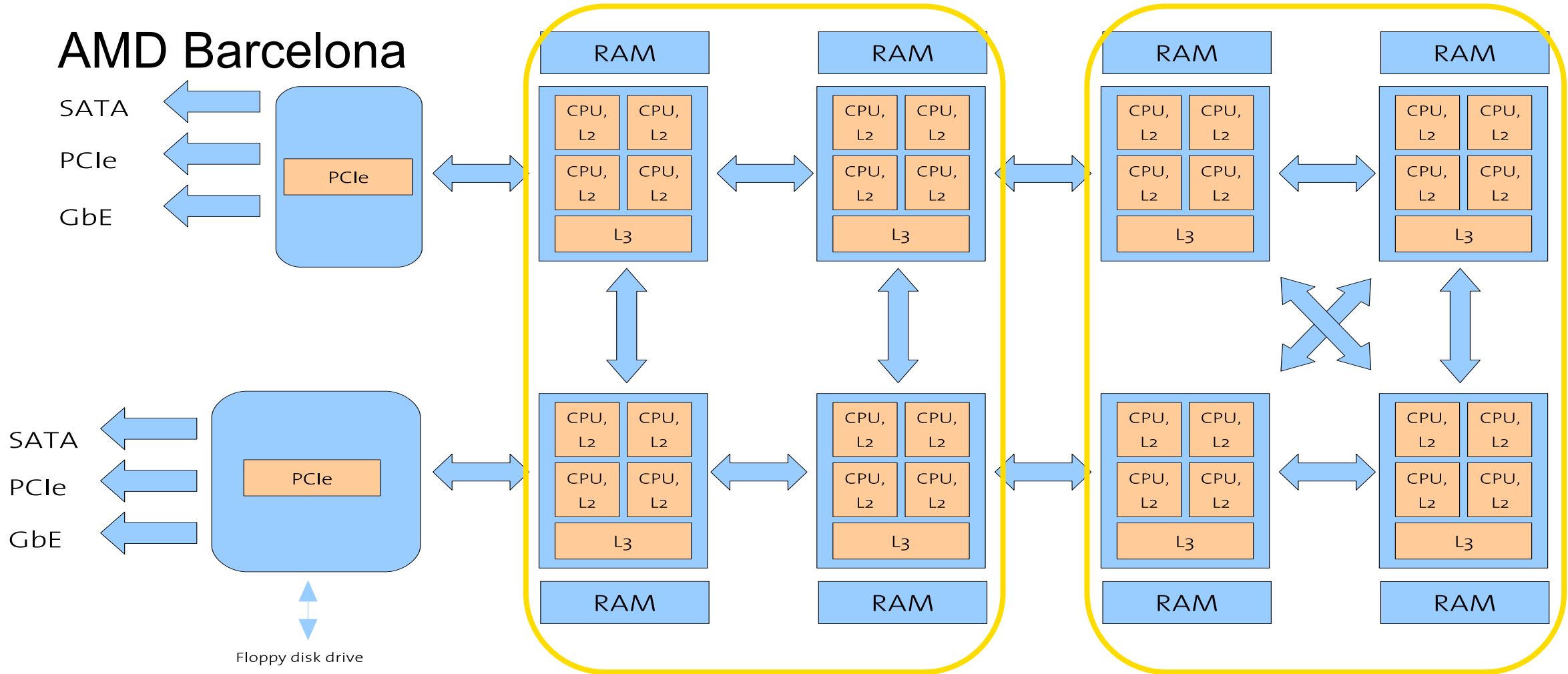

# Interconnect (Latency)

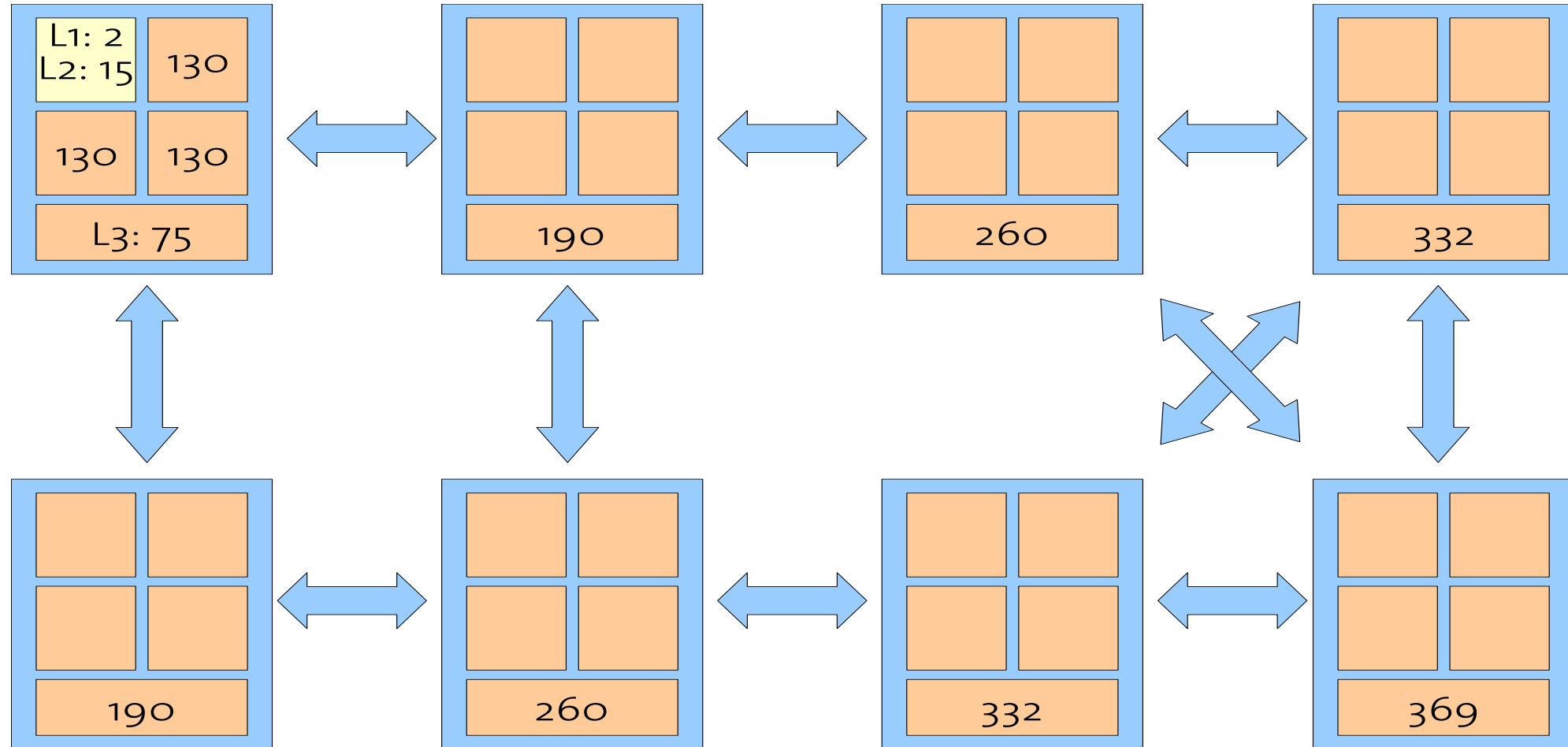



# Interconnect

## Tilera Tile64, Intel Polaris: Mesh network(s)

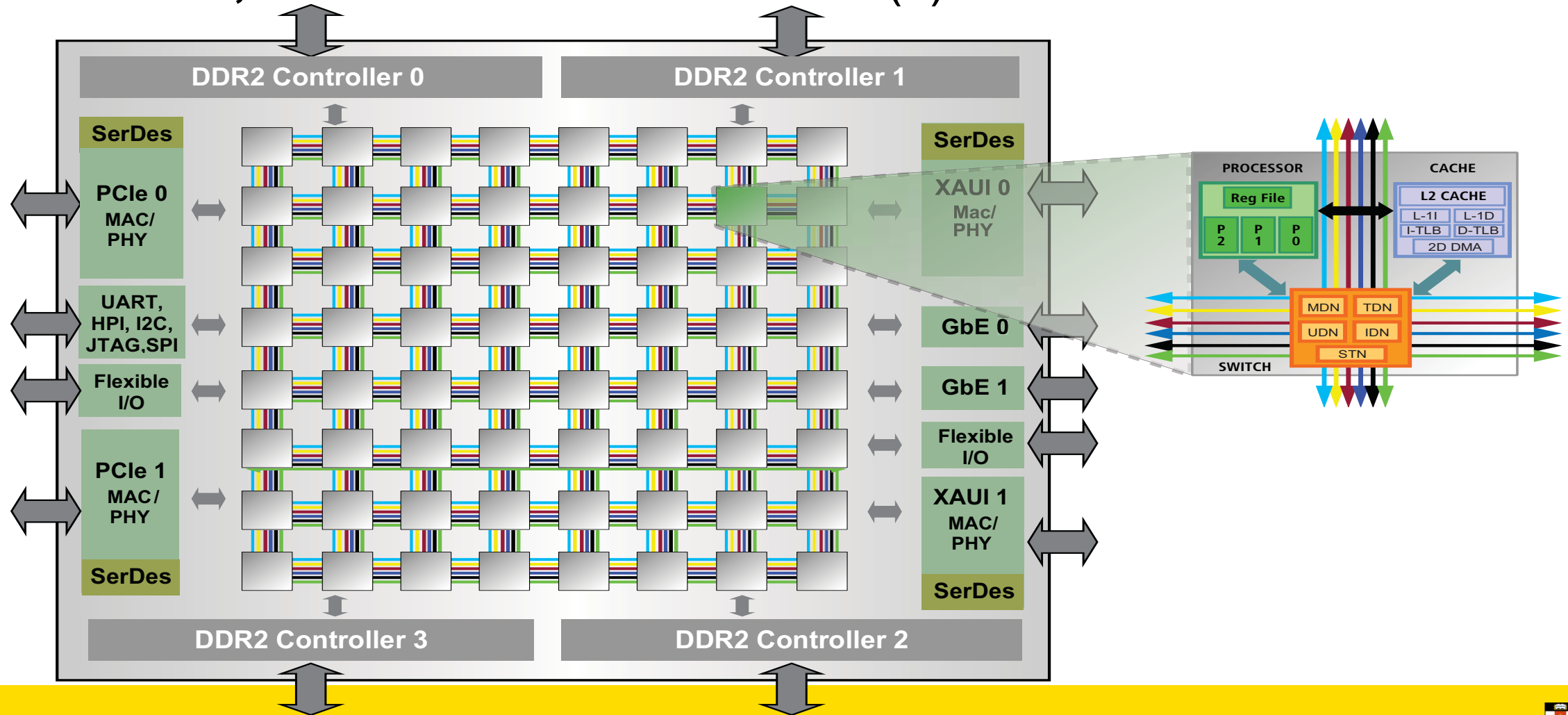

# Interconnect

## Beehive

- Ring
- No hardware cache coherence

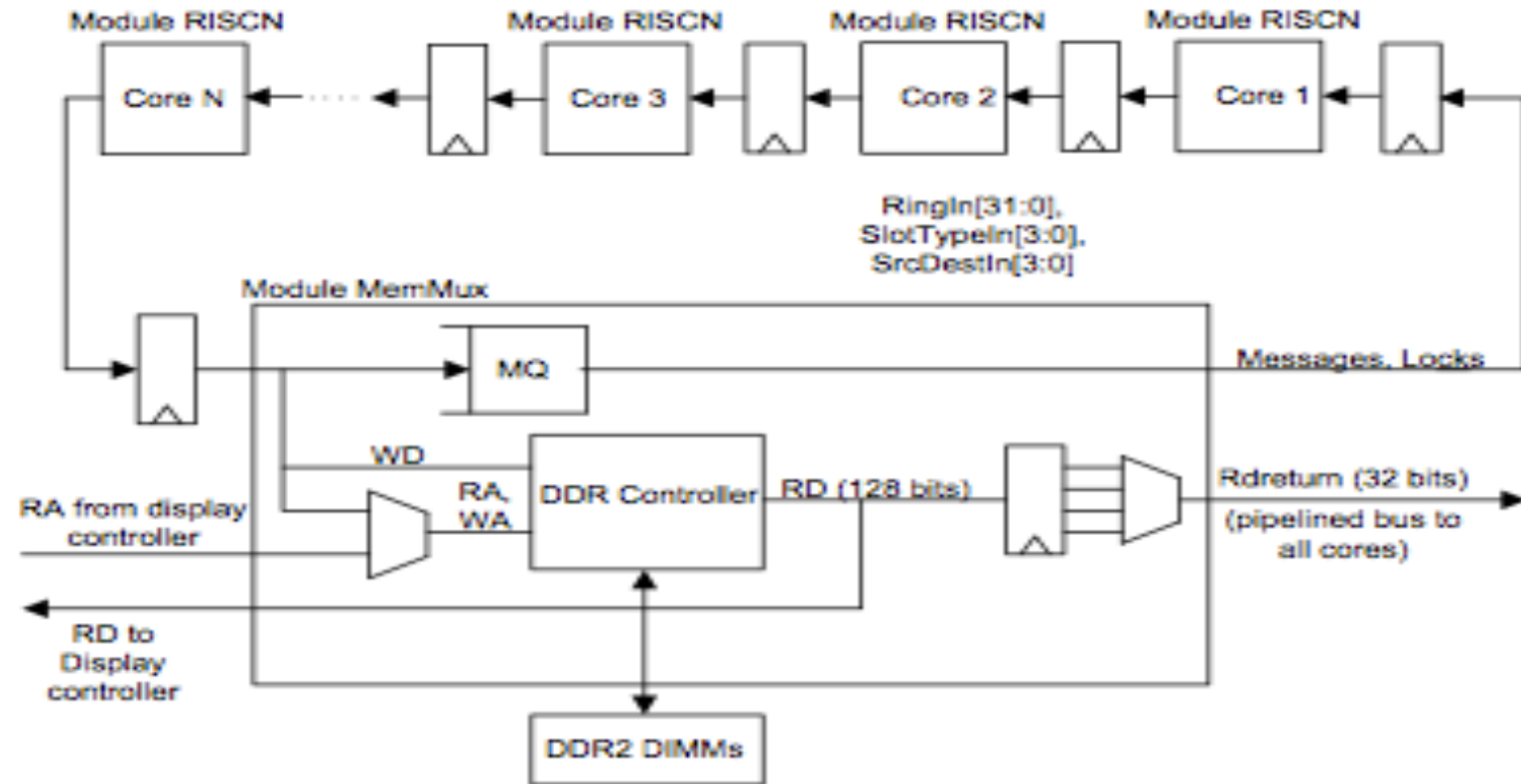

# Interconnect

Intel MIC (Multi Integrated Core) (Knight's Corner/Landing - Xeon Phi)

- Multiple rings
  - Directional
  - Data rings
  - Address rings
  - Coherence rings

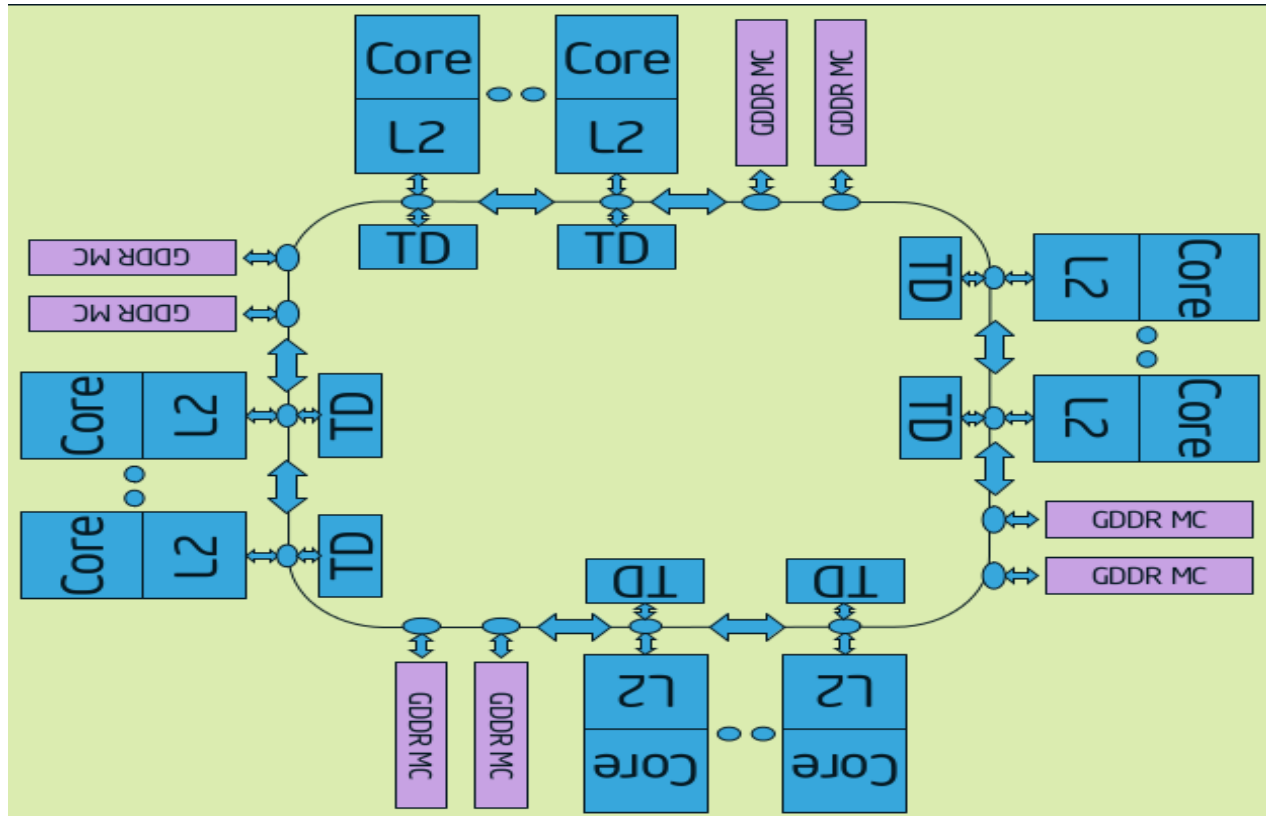

# Interconnect

## Haswell EP Die Configurations

14-18 Core (HCC)

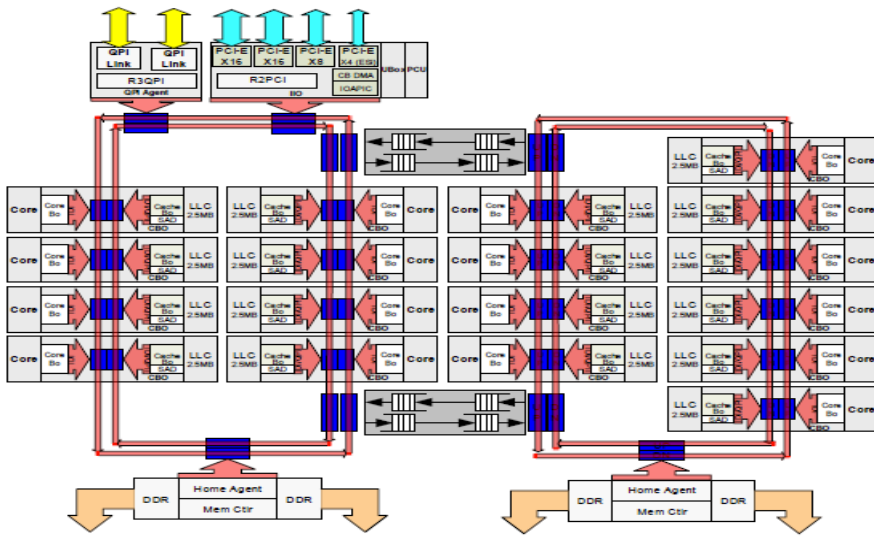

10-12 Core (MCC)

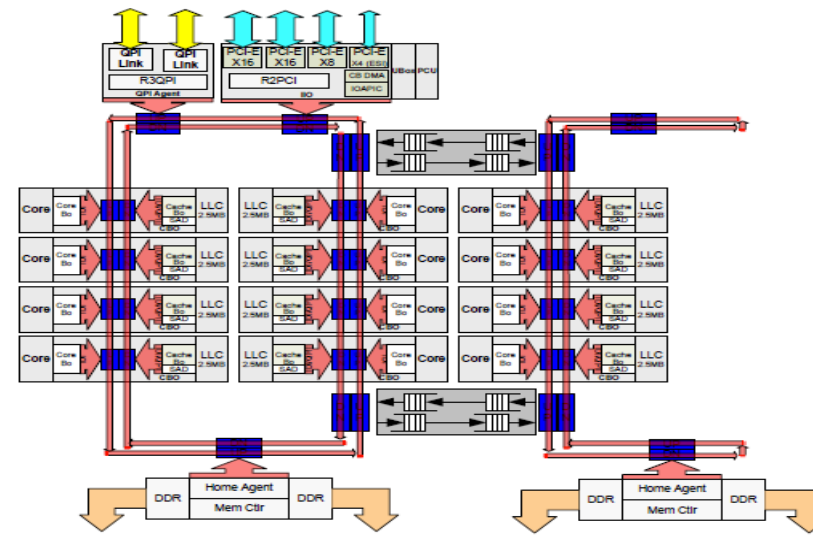

4-8 Core (LCC)

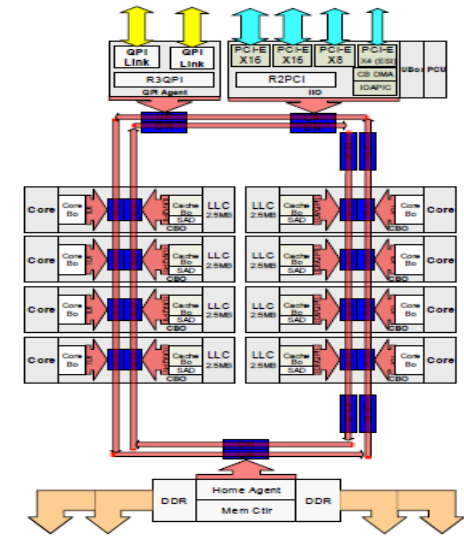

Not representative of actual die-sizes, orientation and layouts – for informational use only.

Chop	Columns	Home Agents	Cores	Power (W)	Transistors (B)	Die Area (mm <sup>2</sup> )
HCC	4	2	14-18	110-145	5.69	662
MCC	3	2	6-12	65-160	3.84	492
LCC	2	1	4-8	55-140	2.60	354





# Interconnect/Structure/Memory

## Cluster on Die (COD) Mode

- Supported on 1S & 2S SKUs with 2 Home Agents (10+ cores)
- In memory directory bits & directory cache used on 2S to reduce coherence traffic and cache-to-cache transfer latencies
- Targeted at NUMA optimized workloads where latency is more important than sharing across Caching Agents
  - Reduces average LLC hit and local memory latencies
  - HA sees most requests from reduced set of threads potentially offering higher effective memory bandwidth
- OS/VMM own NUMA and process affinity decisions

COD Mode for 18C E5-2600 v3

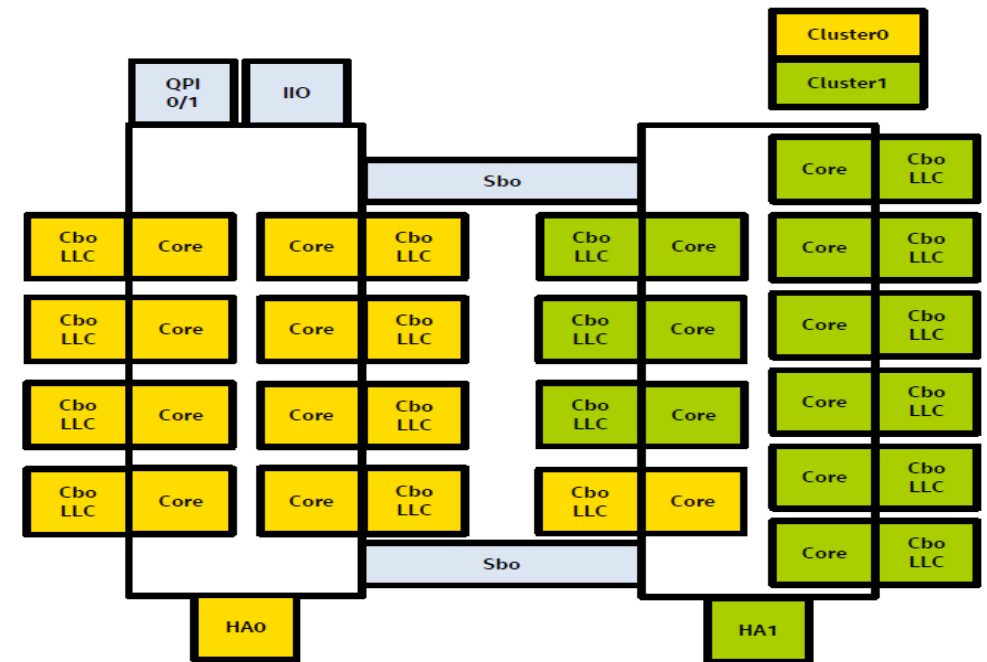

# Interconnect

## Skylake SP

- Server
- Mesh
  - Array of half-rings
- Sub-NUMA clustering (replacing CoD)
  - separate memory domains
- Per core LLC slice
  - Directory based coherency

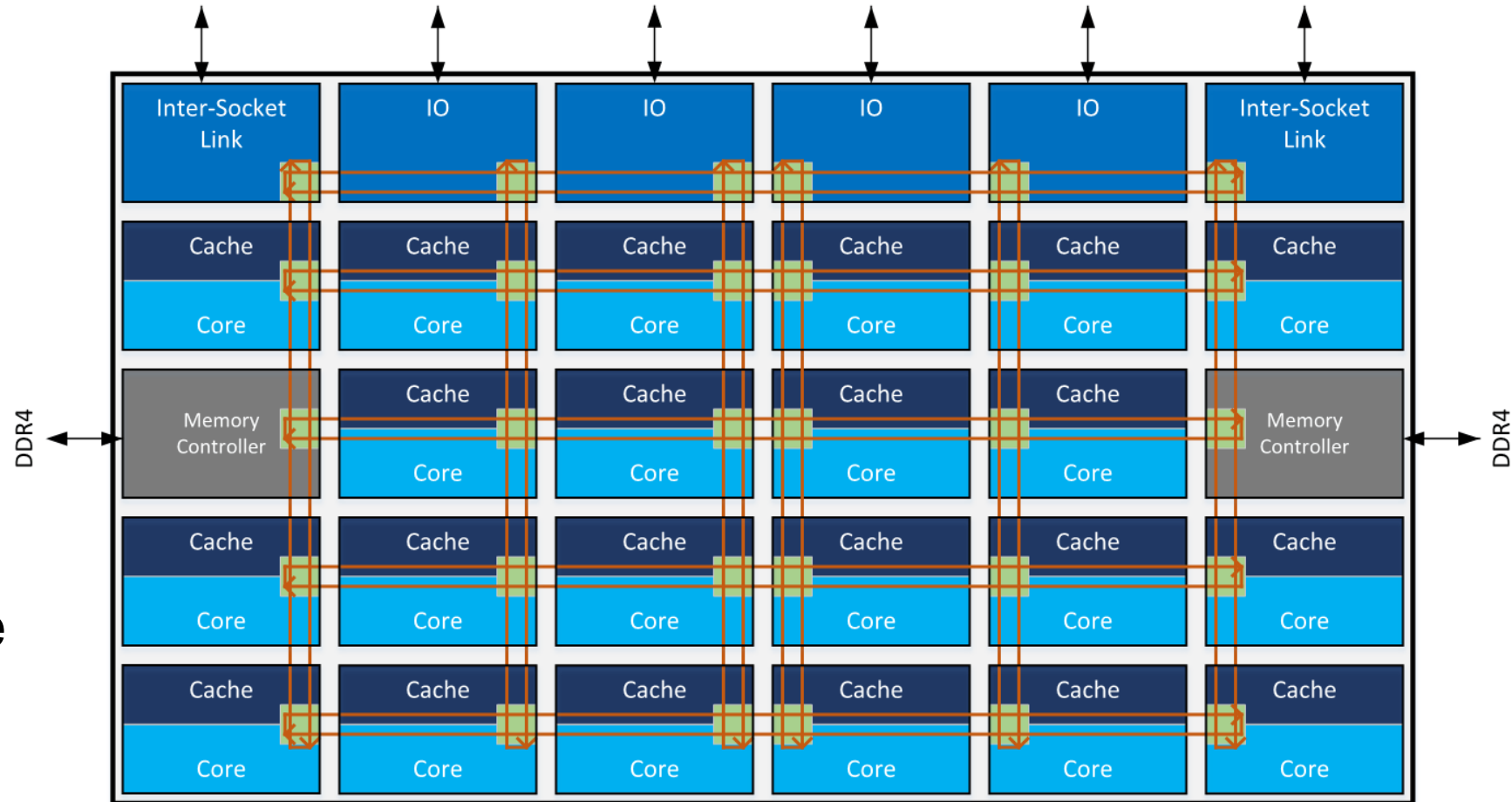

# Interprocessor Communication

Intel SCC – explicit message passing buffer

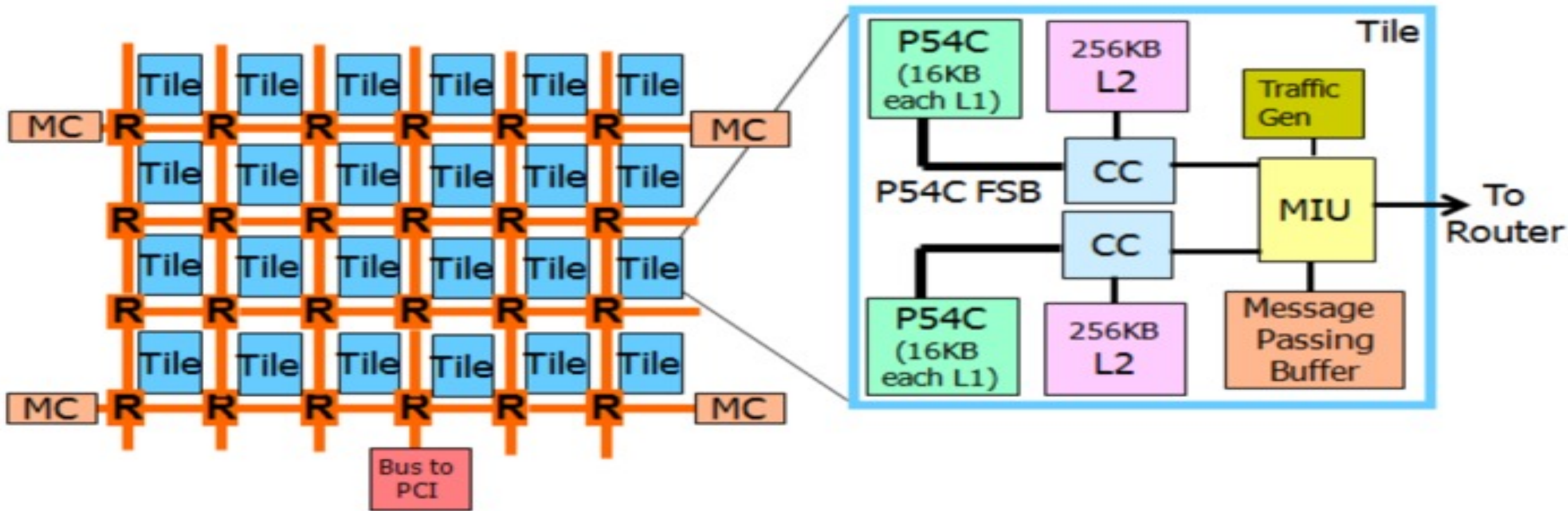

# Summary

## Scalability

- 100+ cores
- Amdahl's law really kicks in

## Heterogeneity

- Heterogeneous cores, memory, etc.
- Properties of similar systems may vary wildly (e.g. interconnect topology and latencies between different AMD platforms)

## NUMA

- Also variable latencies due to topology and cache coherence

## Cache coherence may not be possible

- Can't use it for locking
- Shared data structures require explicit work

## Computer is a distributed system

- Message passing
- Consistency and Synchronisation
- Fault tolerance