

COMP2121: Microprocessors and Interfacing

Lecture 24: Serial Input/Output (I)

<http://www.cse.unsw.edu.au/~cs2121>

Lecturer: Hui Wu

Session 1, 2006

Overview

- The Components of a Asynchronous Communication System
- Standards for the Serial I/O Interface
- RS232-C and Other Standards

Why Serial I/O?

Problems with Parallel I/O:

- Needs a wire for each bit.
- When the source and destination are more than a few feet the parallel cable can be bulky and expensive.
- Susceptible to reflections and induced noise for long distance communication.

Serial I/O provides a solution to these problems.

The Components of a Asynchronous Communication System

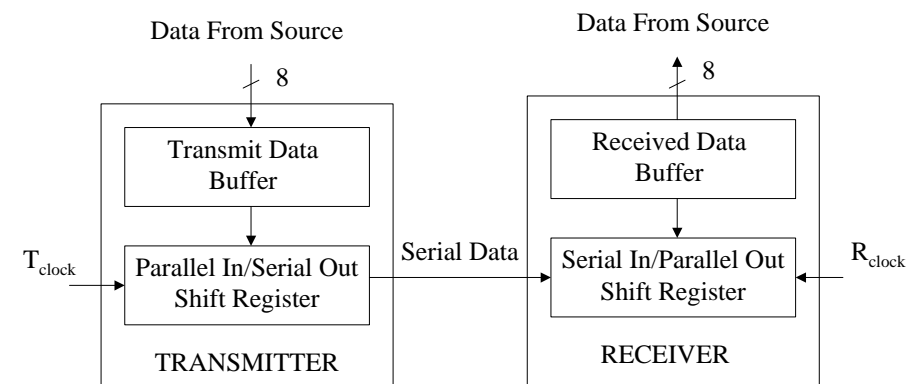

The Components of a Asynchronous Communication System (Cont.)

At the communication source:

- The parallel interface transfers data from the source to the **transmit data buffer**.
- These data are shifted into the **parallel in/serial out shift register** and T_{clock} shifts the data out to the receiver.

The Components of a Asynchronous Communication System (Cont.)

At the communication destination:

- R_{clock} shifts each bit received into the **serial in/parallel out shift register**.
- After all data bits have been shifted, they are transferred to the **received data buffer**.
- The data in the received data buffer are transferred to the input operation via the parallel interface.

UART

- The device that implements both transmitter and receiver in a single integrated circuit is called a UART (Universal Asynchronous Receiver/Transmitter).
- UART is the basis for most serial communication hardware.
- Details of UART will be covered in the next lecture.

UART (Cont.)

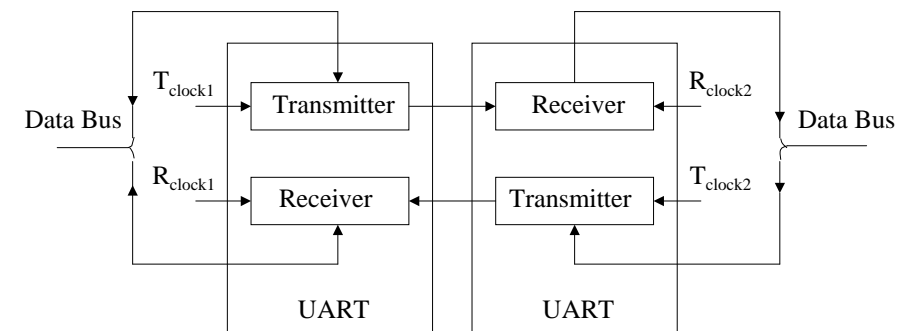

Design Considerations of the Serial Communication System

- How are data to be encoded?
- If the data are sent in serial, which bit is set first?
- How the receiver synchronised with the transmitter?
- What is the data rate?
- How are the electrical signals for logic values defined?
- How does the system provide for handshaking?

Data Encoding and Transmission

- Several codes used for the alphanumeric information.
- The most common is ASCII (American Standard Code for Information Interchange), using 7 bits to encode 96 printable characters and 32 control characters.
- Two choices for the order of data transmission: least significant bit first or most significant bit first.
- USRT uses least significant first order.
- Data are transmitted asynchronously. Therefore, synchronisation between transmitter and receiver is required.
- UART provides a way to synchronise the receiver shift register with the transmitter shift register.

Data Encoding and Transmission (Cont.)

- Data are encapsulated in two other bits called **start bit** and **stop bit**.
- **Mark and space**: the logic one and zero levels are called mark and space.
 - When the transmitter is not sending anything, it holds the line at mark level, also called **idle level**.

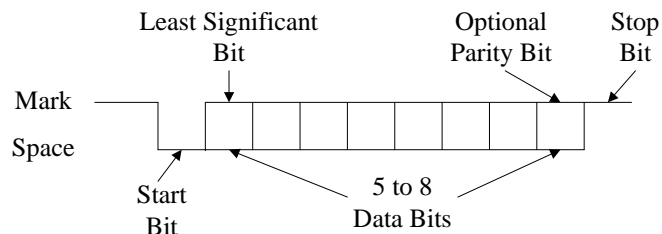

Data Encoding and Transmission (Cont.)

- Typical bits in data transmission:
 - **Start bit**: When the transmitter has data to send, it first changes the line from the mark to the space level for one bit time. This synchronises the receiver with transmitter. When the receiver detects the start bit, it knows to start clocking in the serial data bits.
 - **Data bits**: Almost any number of data bits can be sent between the start and stop bits. Typically, between 5 and 8 bits are used.
 - **Parity bit**: The parity bit, used to detect errors in the data, is added to the data to make the total number of ones odd (odd parity) or even (even parity).
 - **Stop bit**: The stop bit is added at the end of data bits. It gives one bit-time between successive characters. Some systems require more than one stop bit.

Data Transmission Rate

- The rate at which bits are transmitted is called baud rate.
- It is given in bits per second.
- Standard data rates – Baud:
110, 150, 300, 600, 900, 1200, 2400, 4800, 9600, 14400, 19200, 38400, 57800

Standards for the Serial I/O Interface

Interface standards are needed to allow different manufacturers' equipment to be interconnected and must define the following elements:

- Handshaking signals.
- Direction of signal flow.
- Types of communication devices.
- Connectors and interface mechanical considerations.
- Electrical signal levels.

Standards for the Serial I/O Interface (Cont.)

The existing standards include RS-232-C, RS-422, RS-423 and RS-485.

- RS-232-C standard is used in most serial interface.
- If the signals must be transmitted farther than 50 feet or greater than 20 Kbits/second, another electrical interface standard such as RS-422, RS-423 or RS-485 should be chosen.
- For RS-422, RS-423 and RS-485, handshaking, direction of signal flow, and the types of communication devices are based on the RS-232-C standard.

Communication System Types

Three ways that the data can be sent in serial communication system:

- Simplex system:
 - Data are sent in one direction only, say, to a serial printer.
 - If the computer does not send data faster than the printer can accept it, no handshaking signals are required.
 - Two signal wires are needed for this system.

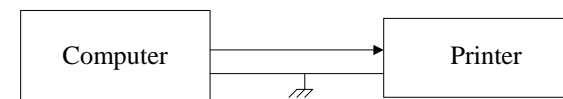

Communication System Types (Cont.)

- Full-duplex (FDX) system:
 - ❑ Data are transmitted in two directions.
 - ❑ It is called four-wire system, although only two signal wires and a common ground are sufficient.

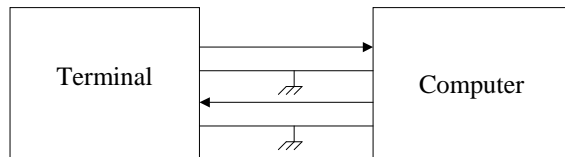

COMP2121: Microprocessors and Interfacing

17

Communication System Types (Cont.)

- Half-duplex (HDX) system:
 - ❑ Data are transmitted in two directions with only one pair of signal lines.
 - ❑ Additional hardware and handshaking signals must be added to an HDX system.

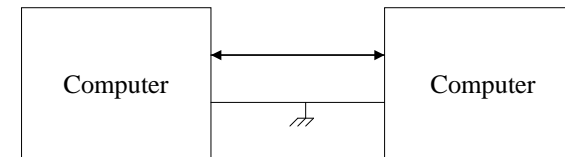

COMP2121: Microprocessors and Interfacing

18

Half-Duplex Handshaking Signals

Figure 1 shows a half-duplex system with additional interface circuitry and handshaking signals defined for the RS-232-C interface standard.

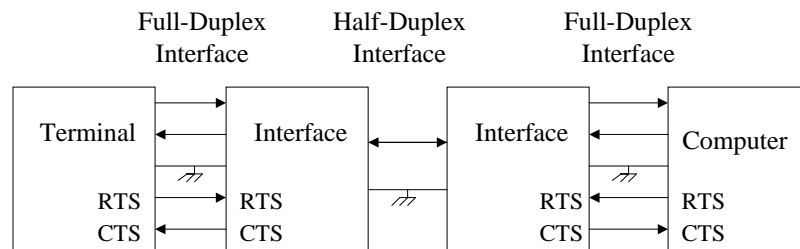

Figure 1 Half-duplex system with handshaking

19

Half-Duplex Handshaking Signals (Cont.)

- The interface blocks have three roles:
 - ❑ They give a full-duplex channel between themselves and the terminal or computer.
 - ❑ They decide whether they or their opposite interface is sending or receiving data
 - ❑ They use and control the **request to send (RTS)** and **clear to send (CTS)** handshaking signals.
 - ❖ The RTS signal is asserted by the terminal or computer when data are to be sent.
 - ❖ When the interface finds that the other system is not sending data, it asserts CTS signal. The sending station must wait until it is clear to send before transmitting.
- Half duplex systems are not often used these days, although the RTS/CTS handshaking signals have been retained to control the flow of data.

20

Data Terminal Equipment and Data Communication Equipment

- The blocks labelled “Interface” in Figure 1 are, in practice, **modems**, and the two-wire half-duplex line is a telephone line.
- Modems are called **data communication equipment (DCE)**.
- The terminals or the computers to which modems are attached to are called **data terminal equipment (DTE)**.
- A modem is a **modulator/demodulator**.
 - ❑ It converts logic levels into tones to be sent over a telephone line.
 - ❑ At the other end of the telephone line, a demodulator converts the tones back to logic levels.
 - ❑ In a half-duplex system, a single set of tones are defined, one for space and one for mark.

21

Data Terminal Equipment and Data Communication Equipment (Cont.)

- Half-duplex modems are no longer used because modem have been developed to allow full-duplex data transmission over a telephone line.
- A full-duplex system has two types of modems, called originate and answer modems, and two sets of tones.

Originate and answer modem tone definitions for Bell 212A

Originate modem	Direction	Answer modem
Modulator tones		Demodulator
1070 Hz — Space	→	
1270 Hz — Mark		
Demodulator		Modulator tones
	←	2025 Hz — Space
		2225 Hz — Mark

22

Modem Handshaking Signals

- Ring Indicator (RI)
 - ❑ The telephone company transmits a special tone that rings the phone. The modem can detect this and asserts the RI signal.
 - ❑ The terminal or computer can use RI to start some special process such as notifying the user that the other end is calling or to answer the telephone in an answer modem.
- Data Set Ready (DSR)
 - ❑ This signal tells the DTE that the modem (also called data set) has established a connection over the telephone line to the far end.

23

Modem Handshaking Signals (Cont.)

- Data Terminal Ready (DTR)
 - ❑ This signal comes from the DTE and inform the modem that it is ready to operate.
 - ❑ This is usually just an indication that the power is turned on in the terminal but could be controlled by a computer.
 - ❑ An intelligent answer modem can use it to answer a call automatically only when the computer or terminal is ready.
- Data Carrier Detect (DCD)
 - ❑ DCD is asserted when the carrier, or tone defined for a mark, is being generated by the modem on the other end.
 - ❑ It was originally used in half-duplex systems.
 - ❖ When one end wanted to transmit, it first asserted the RTS line. The modem then checked the DCD bit. If it found it asserted, it knew the other end was sending. When DCD was deasserted, CTS was asserted, allowing transmission from the requesting terminal.

24

Modem Handshaking Signals (Cont.)

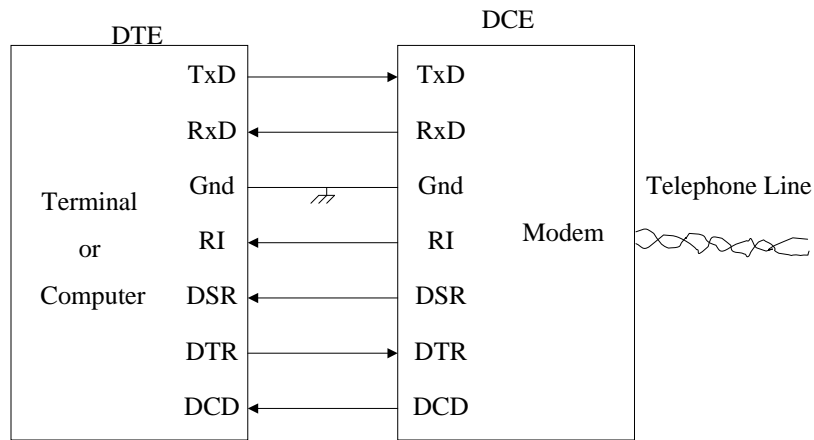

RS-232-C Signal Definitions

DE9	DB25	Signal	Purpose
	1	PG	Protective ground: this is actually the shield in a shielded cable. It is designed to be connected to the equipment frame and may be connected to external grounds.
3	2	TxD	Transmitted data: Sourced by DTE and received by DCE. Data terminal equipment cannot send unless RTS, CTS, DSR and DTR are asserted.
2	3	RxD	Received data: Received by DTE, sourced by DCE.
7	4	RTS	Request to send: Sourced by DTE, received by DCE. RTS is asserted by the DTE when it wants to send data. The DCE responds by asserting CTS.

RS-232-C Signal Definitions (Cont.)

DE9	DB25	Signal	Purpose
8	5	CTS	Clear to send: Sourced by DCE, received by DTE. CTS must be asserted before the DTE can transmit data.
6	6	DSR	Data set ready: Sourced by DCE and received by DTE. Indicates that the DCE has made a connection on the telephone line and is ready to receive data from the terminal. The DTE must see this asserted before it can transmit data.
5	7	SG	Signal ground: Ground reference for this signal is separate from pin 1, protective ground.

RS-232-C Signal Definitions (Cont.)

DE9	DB25	Signal	Purpose
1	8	DCD	Data carrier detect: Sourced by DCE, received by DTE. Indicates that a DCE has detected the carrier on the telephone line. Originally it was used in half-duplex systems but can be used in full-duplex systems, too.
4	20	DTR	Data terminal ready: Sourced by DTE and received by DCE. Indicates that DTE is ready to send or receive data.
9	22	RI	Ring indicator: Sourced by DCE and received by DTE. Indicates that a ringing signal is detected.

RS-232-C Interconnections

- When two serial ports are connected, the data rate, the number of data bits, whether parity is used, the type of parity, and the number of stop bits must be set properly and identically on each UART.
- Proper cables must be used. There are three kinds of cables from which to choose, depending on the types of devices to be interconnected.
 - The full DTE – DCE cable.
 - The DTE – DTE null modem cable.
 - The minimal DTE – DCE cable.

RS-232-C Interconnections (Cont.)

	DE9	DB25		DB25	DE9	
	DTE	DTE		DCE	DCE	
TxD	3	2	→	2	3	TxD
RxD	2	3	←	3	2	RxD
SG	5	7	—	7	5	SG
RTS	7	4	→	4	7	RTS
CTS	8	5	←	5	8	CTS
DCD	1	8	←	8	1	DCD
DSR	6	6	←	6	6	DSR
DTR	4	20	→	20	4	DTR

Full DTE – DCE cable

RS-232-C Interconnections (Cont.)

	DE9	DB25		DB25	DE9	
	DTE	DTE		DCE	DCE	
TxD	3	2	→	2	3	TxD
RxD	2	3	←	3	2	RxD
SG	5	7	—	7	5	SG
RTS	7	4	→	4	7	RTS
CTS	8	5	←	5	8	CTS
DCD	1	8	←	8	1	DCD
DSR	6	6	←	6	6	DSR
DTR	4	20	→	20	4	DTR

DTE – DTE null modem cable

RS-232-C Interconnections (Cont.)

	DE9	DB25		DB25	DE9	
	DTE	DTE		DCE	DCE	
TxD	3	2	→	2	3	TxD
RxD	2	3	←	3	2	RxD
SG	5	7	—	7	5	SG
RTS	7	4	→	4	7	RTS
CTS	8	5	←	5	8	CTS
DCD	1	8	←	8	1	DCD
DSR	6	6	←	6	6	DSR
DTR	4	20	→	20	4	DTR

Minimal three-wire cable

RS-232-C Interconnections (Cont.)

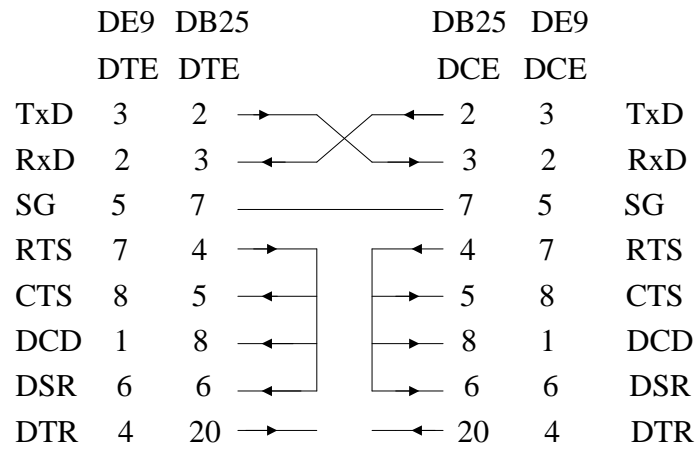

Minimal null modem cable

33

RS-232-C Interface

RS-232-C Logic levels:

Mark -25 to -3 volts

Space +25 to +3 volts

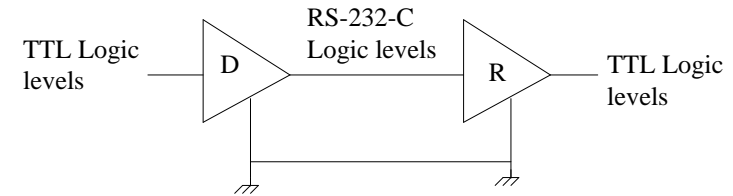

COMP2121: Microprocessors and Interfacing

34

RS-423 Standard

- Also a single ended system.
- Allows longer distance and higher data rates than RS-232-C.
- Allows a driver to broadcast data to 10 receivers.

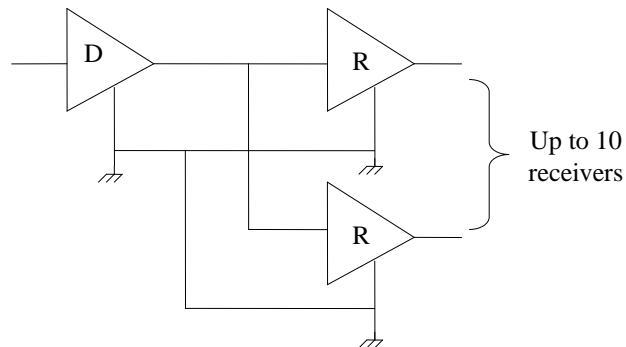

RS-423 Interface

35

RS-422 Standard

- RS-422 line drivers and receivers operates with differential amplifier.
 - These drivers eliminate much of the common-mode noise experienced with long transmission lines, thus allowing the longer distances and higher data rates.

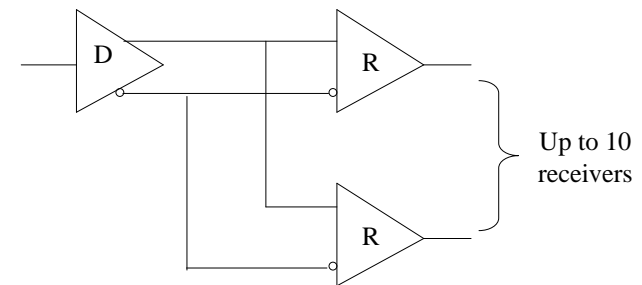

RS-422 Interface

36

RS-485 Standard

- Similar to RS-422 in that it uses differential line drivers and receivers.
- Unlike RS-422, RS-485 provides for multiple drivers and receivers in a bussed environment.
 - ❑ Up to 32 drivers/receivers pairs can be used together.

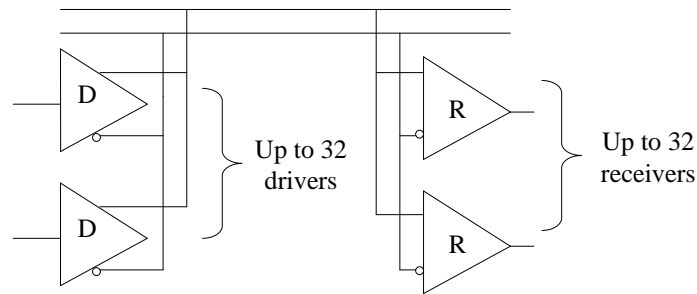

RS-485 Interface

37

Line Lengths and Data Rates

RS-423 line length and data rate

Line length (ft)	Data rate
30	100 Kbits/s
300	10 Kbits/s
4000	1 Kbits/s

RS-422 line length and data rate

Line length (ft)	Data rate
40	10 Mbits/s
400	1 Mbits/s
4000	100 Kbits/s

RS-485 line length and data rate

Line length (ft)	Data rate
40	10 Mbits/s
400	1 Mbits/s
4000	100 Kbits/s

38

Summary of Standards

Specification	RS-232-C	RS-423	RS-422	RS-485
Receiver input voltage	± 3 to ± 15 V	± 200 mV to ± 12 V	± 200 mV to ± 7 V	± 200 mV to -7 to $+12$ V
Driver output signal	± 5 to ± 15 V	± 3.6 to ± 6 V	± 2 to ± 5 V	± 1.5 to ± 5 V
Maximum data rate	20 Kb/s	100 Kb/s	10 Mb/s	10 Mb/s
Maximum cable length	50 ft	4000 ft	4000 ft	4000 ft
Driver source Impedance	3-7 K Ω	450 Ω min	100 Ω	54 Ω
Receiver input resistance	3 K Ω	4 K Ω min	4 K Ω min	12 K Ω minimum
Mode	Singled-ended	Singled-ended	Differential	Differential
Number of drivers and receivers allowed on one line	1 Driver	1 driver	1 Driver	32 Driver
	1 Receivers	10 Receivers	10 Receivers	32 Receivers

39

Reading

1. Chapter 10: Serial Input/Output. Microcontrollers and Microcomputers by Fredrick M. Cady.
2. http://www.camiresearch.com/Data_Com_Basics/RS_232_standard.html.
3. <http://www.beyondlogic.org/serial/serial.htm>.