

VHDL Tutorial

Peter J. Ashenden

EDA CONSULTANT, ASHENDEN DESIGNS PTY. LTD.
www.ashenden.com.au

© 2004 by Elsevier Science (USA)
All rights reserved

1

Introduction

The purpose of this tutorial is to describe the modeling language VHDL. VHDL includes facilities for describing logical structure and function of digital systems at a number of levels of abstraction, from system level down to the gate level. It is intended, among other things, as a modeling language for specification and simulation. We can also use it for hardware synthesis if we restrict ourselves to a subset that can be automatically translated into hardware.

VHDL arose out of the United States government's Very High Speed Integrated Circuits (VHSIC) program. In the course of this program, it became clear that there was a need for a standard language for describing the structure and function of integrated circuits (ICs). Hence the VHSIC Hardware Description Language (VHDL) was developed. It was subsequently developed further under the auspices of the Institute of Electrical and Electronic Engineers (IEEE) and adopted in the form of the IEEE Standard 1076, *Standard VHDL Language Reference Manual*, in 1987. This first standard version of the language is often referred to as VHDL-87.

Like all IEEE standards, the VHDL standard is subject to review at least every five years. Comments and suggestions from users of the 1987 standard were analyzed by the IEEE working group responsible for VHDL, and in 1992 a revised version of the standard was proposed. This was eventually adopted in 1993, giving us VHDL-93. A further round of revision of the standard was started in 1998. That process was completed in 2001, giving us the current version of the language, VHDL-2002.

This tutorial describes language features that are common to all versions of the language. They are expressed using the syntax of VHDL-93 and subsequent versions. There are some aspects of syntax that are incompatible with the original VHDL-87 version. However, most tools now support at least VHDL-93, so syntactic differences should not cause problems.

The tutorial does not comprehensively cover the language. Instead, it introduces the basic language features that are needed to get started in modeling relatively simple digital systems. For a full coverage, the reader is referred to *The Designer's Guide to VHDL, 2nd Edition*, by Peter J. Ashenden, published by Morgan Kaufman Publishers (ISBN 1-55860-674-2).

2

Fundamental Concepts

2.1 Modeling Digital Systems

The term digital systems encompasses a range of systems from low-level components to complete system-on-a-chip and board-level designs. If we are to encompass this range of views of digital systems, we must recognize the complexity with which we are dealing. It is not humanly possible to comprehend such complex systems in their entirety. We need to find methods of dealing with the complexity, so that we can, with some degree of confidence, design components and systems that meet their requirements.

The most important way of meeting this challenge is to adopt a systematic methodology of design. If we start with a requirements document for the system, we can design an abstract structure that meets the requirements. We can then decompose this structure into a collection of components that interact to perform the same function. Each of these components can in turn be decomposed until we get to a level where we have some ready-made, primitive components that perform a required function. The result of this process is a hierarchically composed system, built from the primitive elements.

The advantage of this methodology is that each subsystem can be designed independently of others. When we use a subsystem, we can think of it as an abstraction rather than having to consider its detailed composition. So at any particular stage in the design process, we only need to pay attention to the small amount of information relevant to the current focus of design. We are saved from being overwhelmed by masses of detail.

We use the term *model* to mean our understanding of a system. The model represents that information which is relevant and abstracts away from irrelevant detail. The implication of this is that there may be several models of the same system, since different information is relevant in different contexts. One kind of model might concentrate on representing the function of the system, whereas another kind might represent the way in which the system is composed of subsystems.

There are a number of important motivations for formalizing this idea of a model, including

- expressing system requirements in a complete and unambiguous way
- documenting the functionality of a system
- testing a design to verify that it performs correctly

- formally verifying properties of a design
- synthesizing an implementation in a target technology (e.g., ASIC or FPGA)

The unifying factor is that we want to achieve maximum reliability in the design process for minimum cost and design time. We need to ensure that requirements are clearly specified and understood, that subsystems are used correctly and that designs meet the requirements. A major contributor to excessive cost is having to revise a design after manufacture to correct errors. By avoiding errors, and by providing better tools for the design process, costs and delays can be contained.

2.2 VHDL Modeling Concepts

In this section, we look at the basic VHDL concepts for behavioral and structural modeling. This will provide a feel for VHDL and a basis from which to work in later chapters. As an example, we look at ways of describing a four-bit register, shown in Figure 2-1.

Using VHDL terminology, we call the module `reg4` a design *entity*, and the inputs and outputs are *ports*. Figure 2-2 shows a VHDL description of the interface to this entity. This is an example of an *entity declaration*. It introduces a name for the entity and lists the input and output ports, specifying that they carry bit values ('0' or '1') into and out of the entity. From this we see that an entity declaration describes the external view of the entity.

FIGURE 2-1

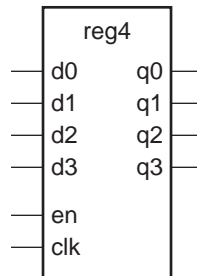

A four-bit register module. The register is named `reg4` and has six inputs, `d0`, `d1`, `d2`, `d3`, `en` and `clk`, and four outputs, `q0`, `q1`, `q2` and `q3`.

FIGURE 2-2

```
entity reg4 is
  port ( d0, d1, d2, d3, en, clk : in bit;
         q0, q1, q2, q3 : out bit );
end entity reg4;
```

A VHDL entity description of a four-bit register.

Elements of Behavior

In VHDL, a description of the internal implementation of an entity is called an *architecture body* of the entity. There may be a number of different architecture bodies of the one interface to an entity, corresponding to alternative implementations that perform the same function. We can write a *behavioral* architecture body of an entity, which describes the function in an abstract way. Such an architecture body includes only *process statements*, which are collections of actions to be executed in sequence. These actions are called *sequential statements* and are much like the kinds of statements we see in a conventional programming language. The types of actions that can be performed include evaluating expressions, assigning values to variables, conditional execution, repeated execution and subprogram calls. In addition, there is a sequential statement that is unique to hardware modeling languages, the *signal assignment* statement. This is similar to variable assignment, except that it causes the value on a signal to be updated at some future time.

To illustrate these ideas, let us look at a behavioral architecture body for the `reg4` entity, shown in Figure 2-3. In this architecture body, the part after the first **begin** keyword includes one process statement, which describes how the register behaves. It starts with the process name, `storage`, and finishes with the keywords **end process**.

FIGURE 2-3

```

architecture behav of reg4 is
begin
    storage : process is
        variable stored_d0, stored_d1, stored_d2, stored_d3 : bit;
    begin
        wait until clk = '1';
        if en = '1' then
            stored_d0 := d0;
            stored_d1 := d1;
            stored_d2 := d2;
            stored_d3 := d3;
        end if;
        q0 <= stored_d0 after 5 ns;
        q1 <= stored_d1 after 5 ns;
        q2 <= stored_d2 after 5 ns;
        q3 <= stored_d3 after 5 ns;
    end process storage;
end architecture behav;

```

A behavioral architecture body of the reg4 entity.

The process statement defines a sequence of actions that are to take place when the system is simulated. These actions control how the values on the entity's ports change over time; that is, they control the behavior of the entity. This process can modify the values of the entity's ports using signal assignment statements.

The way this process works is as follows. When the simulation is started, the signal values are set to '0', and the process is activated. The process's variables (listed

after the keyword **variable**) are initialized to '0', then the statements are executed in order. The first statement is a *wait statement* that causes the process to *suspend*. While the process is suspended, it is *sensitive* to the `clk` signal. When `clk` changes value to '1', the process resumes.

The next statement is a condition that tests whether the `en` signal is '1'. If it is, the statements between the keywords **then** and **end if** are executed, updating the process's variables using the values on the input signals. After the conditional if statement, there are four signal assignment statements that cause the output signals to be updated 5 ns later.

When the process reaches the end of the list of statements, they are executed again, starting from the keyword **begin**, and the cycle repeats. Notice that while the process is suspended, the values in the process's variables are not lost. This is how the process can represent the state of a system.

Elements of Structure

An architecture body that is composed only of interconnected subsystems is called a *structural* architecture body. Figure 2-4 shows how the `reg4` entity might be composed of D-flipflops. If we are to describe this in VHDL, we will need entity declarations and architecture bodies for the subsystems, shown in Figure 2-5.

Figure 2-6 is a VHDL architecture body declaration that describes the structure shown in Figure 2-4. The *signal declaration*, before the keyword **begin**, defines the internal signals of the architecture. In this example, the signal `int_clk` is declared to carry a bit value ('0' or '1'). In general, VHDL signals can be declared to carry arbitrarily complex values. Within the architecture body the ports of the entity are also treated as signals.

In the second part of the architecture body, a number of *component instances* are created, representing the subsystems from which the `reg4` entity is composed. Each component instance is a copy of the entity representing the subsystem, using the corresponding *basic* architecture body. (The name `work` refers to the current working library, in which all of the entity and architecture body descriptions are assumed to be held.)

The *port map* specifies the connection of the ports of each component instance to signals within the enclosing architecture body. For example, `bit0`, an instance of the `d_ff` entity, has its port `d` connected to the signal `d0`, its port `clk` connected to the signal `int_clk` and its port `q` connected to the signal `q0`.

Test Benches

We often test a VHDL model using an enclosing model called a *test bench*. The name comes from the analogy with a real hardware test bench, on which a device under test is stimulated with signal generators and observed with signal probes. A VHDL test bench consists of an architecture body containing an instance of the component to be tested and processes that generate sequences of values on signals connected to the component instance. The architecture body may also contain processes that test that the component instance produces the expected values on its output signals. Alternatively, we may use the monitoring facilities of a simulator to observe the outputs.

FIGURE 2-4

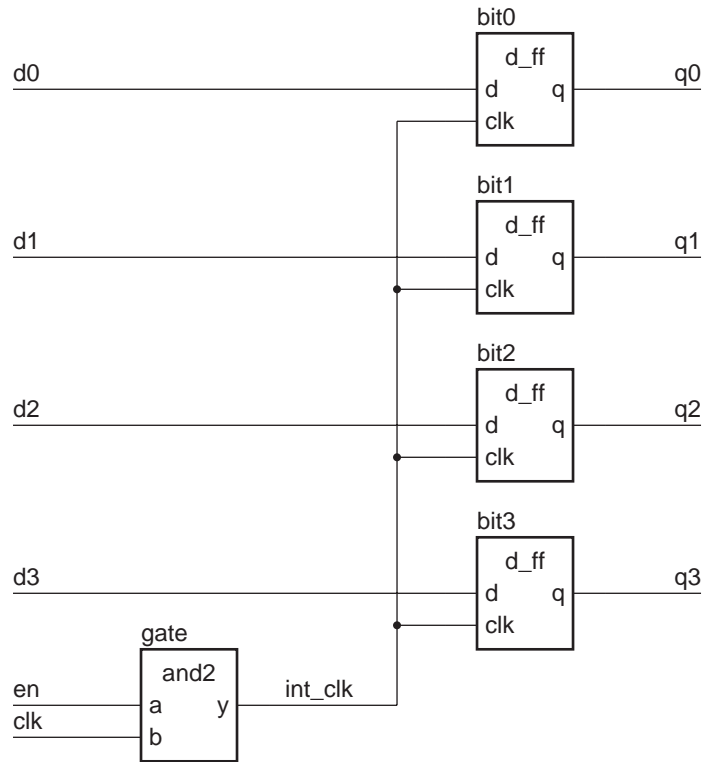

A structural composition of the reg4 entity.

FIGURE 2-5

```

entity d_ff is
  port ( d, clk : in bit; q : out bit );
end d_ff;

architecture basic of d_ff is
begin
  ff_behavior : process is
  begin
    wait until clk = '1';
    q <= d after 2 ns;
  end process ff_behavior;
end architecture basic;

```

```

entity and2 is
  port ( a, b : in bit; y : out bit );
end and2;

```

```

architecture basic of and2 is
begin
    and2_behavior : process is
        begin
            y <= a and b after 2 ns;
            wait on a, b;
        end process and2_behavior;
end architecture basic;

```

Entity declarations and architecture bodies for D-flipflop and two-input and gate.

FIGURE 2-6

```

architecture struct of reg4 is
    signal int_clk : bit;
begin
    bit0 : entity work.d_ff(basic)
        port map (d0, int_clk, q0);
    bit1 : entity work.d_ff(basic)
        port map (d1, int_clk, q1);
    bit2 : entity work.d_ff(basic)
        port map (d2, int_clk, q2);
    bit3 : entity work.d_ff(basic)
        port map (d3, int_clk, q3);
    gate : entity work.and2(basic)
        port map (en, clk, int_clk);
end architecture struct;

```

A VHDL structural architecture body of the reg4 entity.

A test bench model for the behavioral implementation of the `reg4` register is shown in Figure 2-7. The entity declaration has no port list, since the test bench is entirely self-contained. The architecture body contains signals that are connected to the input and output ports of the component instance `dut`, the device under test. The process labeled `stimulus` provides a sequence of test values on the input signals by performing signal assignment statements, interspersed with wait statements. We can use a simulator to observe the values on the signals `q0` to `q3` to verify that the register operates correctly. When all of the stimulus values have been applied, the stimulus process waits indefinitely, thus completing the simulation.

FIGURE 2-7

```

entity test_bench is
end entity test_bench;
architecture test_reg4 of test_bench is
    signal d0, d1, d2, d3, en, clk, q0, q1, q2, q3 : bit;
begin

```

```

dut : entity work.reg4(behav)
      port map ( d0, d1, d2, d3, en, clk, q0, q1, q2, q3 );
stimulus : process is
begin
d0 <= '1'; d1 <= '1'; d2 <= '1'; d3 <= '1';
en <= '0'; clk <= '0';
wait for 10 ns;
en <= '1'; wait for 10 ns;
clk = '1', '0' after 10 ns; wait for 20 ns;
d0 <= '0'; d1 <= '0'; d2 <= '0'; d3 <= '0';
en <= '0'; wait for 10 ns;
clk <= '1', '0' after 10 ns; wait for 20 ns;
...
      wait;
end process stimulus;
end architecture test_reg4;

```

A VHDL test bench for the reg4 register model.

Analysis, Elaboration and Execution

One of the main reasons for writing a model of a system is to enable us to simulate it. This involves three stages: *analysis*, *elaboration* and *execution*. Analysis and elaboration are also required in preparation for other uses of the model, such as logic synthesis.

In the first stage, analysis, the VHDL description of a system is checked for various kinds of errors. Like most programming languages, VHDL has rigidly defined *syntax* and *semantics*. The syntax is the set of grammatical rules that govern how a model is written. The rules of semantics govern the meaning of a program. For example, it makes sense to perform an addition operation on two numbers but not on two processes.

During the analysis phase, the VHDL description is examined, and syntactic and static semantic errors are located. The whole model of a system need not be analyzed at once. Instead, it is possible to analyze *design units*, such as entity and architecture body declarations, separately. If the analyzer finds no errors in a design unit, it creates an intermediate representation of the unit and stores it in a library. The exact mechanism varies between VHDL tools.

The second stage in simulating a model, elaboration, is the act of working through the design hierarchy and creating all of the objects defined in declarations. The ultimate product of design elaboration is a collection of signals and processes, with each process possibly containing variables. A model must be reducible to a collection of signals and processes in order to simulate it.

The third stage of simulation is the execution of the model. The passage of time is simulated in discrete steps, depending on when events occur. Hence the term *discrete event simulation* is used. At some simulation time, a process may be stimulated by changing the value on a signal to which it is sensitive. The process is resumed and may schedule new values to be given to signals at some later simulated time. This is called *scheduling a transaction* on that signal. If the new value is different from the

previous value on the signal, an *event* occurs, and other processes sensitive to the signal may be resumed.

The simulation starts with an *initialization phase*, followed by repetitive execution of a *simulation cycle*. During the initialization phase, each signal is given an initial value, depending on its type. The simulation time is set to zero, then each process instance is activated and its sequential statements executed. Usually, a process will include a signal assignment statement to schedule a transaction on a signal at some later simulation time. Execution of a process continues until it reaches a wait statement, which causes the process to be suspended.

During the simulation cycle, the simulation time is first advanced to the next time at which a transaction on a signal has been scheduled. Second, all the transactions scheduled for that time are performed. This may cause some events to occur on some signals. Third, all processes that are sensitive to those events are resumed and are allowed to continue until they reach a wait statement and suspend. Again, the processes usually execute signal assignments to schedule further transactions on signals. When all the processes have suspended again, the simulation cycle is repeated. When the simulation gets to the stage where there are no further transactions scheduled, it stops, since the simulation is then complete.

3

VHDL is Like a Programming Language

3.1 Lexical Elements and Syntax

When we learn a new language, we need to learn how to write the basic elements, such as numbers and identifiers. We also need to learn the syntax, that is, the grammar rules governing how we form language constructs. We will briefly describe the lexical elements and our notation for the grammar rules, and then start to introduce language features.

VHDL uses characters in the ISO 8859 Latin-1 8-bit character set. This includes uppercase and lowercase letters (including letters with diacritical marks, such as ‘à’, ‘ä’ and so forth), digits 0 to 9, punctuation and other special characters.

Comments

When we are writing a hardware model in VHDL, it is important to annotate the code with comments. A VHDL model consists of a number of lines of text. A comment can be added to a line by writing two dashes together, followed by the comment text. For example:

```
... a line of VHDL description ...    -- a descriptive comment
```

The comment extends from the two dashes to the end of the line and may include any text we wish, since it is not formally part of the VHDL model. The code of a model can include blank lines and lines that only contain comments, starting with two dashes. We can write long comments on successive lines, each starting with two dashes, for example:

```
-- The following code models  
-- the control section of the system  
... some VHDL code ...
```

Identifiers

Identifiers are used to name items in a VHDL model. An identifier

- may only contain alphabetic letters ('A' to 'Z' and 'a' to 'z'), decimal digits ('0' to '9') and the underline character ('_');
- must start with an alphabetic letter;
- may not end with an underline character; and
- may not include two successive underline characters.

Case of letters is not significant. Some examples of valid basic identifiers are

```
A X0 counter Next_Value generate_read_cycle
```

Some examples of invalid basic identifiers are

```
last@value      -- contains an illegal character for an identifier
5bit_counter    -- starts with a nonalphabetic character
_A0             -- starts with an underline
A0_            -- ends with an underline
clock__pulse    -- two successive underlines
```

Reserved Words

Some identifiers, called reserved words or keywords, are reserved for special use in VHDL, so we cannot use them as identifiers for items we define. The full list of reserved words is shown in Figure 3-1.

FIGURE 3-1

abs	disconnect	label	package	sla
access	downto	library	port	sll
after	else	linkage	postponed	sra
alias	elsif	literal	procedure	srl
all	end	loop	process	subtype
and	entity	map	protected	then
architecture	exit	mod	pure	to
array	file	nand	range	transport
assert	for	new	record	type
attribute	function	next	register	unaffected
begin	generate	nor	reject	units
block	generic	not	rem	until
body	group	null	report	use
buffer	guarded	of	return	variable
bus	if	on	rol	wait
case	impure	open	ror	when
component	in	or	select	while
configuration	inertial	others	severity	with
constant	inout	out	shared	xnor
	is		signal	xor

Numbers

There are two forms of numbers that can be written in VHDL code: *integer literals* and *real literals*. An integer literal simply represents a whole number and consists of digits without a decimal point. Real literals, on the other hand, can represent fractional numbers. They always include a decimal point, which is preceded by at least one digit and followed by at least one digit. Some examples of decimal integer literals are

```
23 0 146
```

Some examples of real literals are

```
23.1 0.0 3.14159
```

Both integer and real literals can also use exponential notation, in which the number is followed by the letter 'E' or 'e', and an exponent value. This indicates a power of 10 by which the number is multiplied. For integer literals, the exponent must not be negative, whereas for real literals, it may be either positive or negative. Some examples of integer literals using exponential notation are

```
46E5 1E+12 19e00
```

Some examples of real literals using exponential notation are

```
1.234E09 98.6E+21 34.0e-08
```

Characters

A character literal can be written in VHDL code by enclosing it in single quotation marks. Any of the printable characters in the standard character set (including a space character) can be written in this way. Some examples are

```
'A'    -- uppercase letter
'z'    -- lowercase letter
','    -- the punctuation character comma
'"'    -- the punctuation character single quote
' '    -- the separator character space
```

Strings

A string literal represents a sequence of characters and is written by enclosing the characters in double quotation marks. The string may include any number of characters (including zero), but it must fit entirely on one line. Some examples are

```
"A string"
"We can include any printing characters (e.g., &%@^*) in a string!!"
"00001111ZZZZ"
""      -- empty string
```

If we need to include a double quotation mark character in a string, we write two double quotation mark characters together. The pair is interpreted as just one character in the string. For example:

```
"A string in a string: ""A string"". "
```

If we need to write a string that is longer than will fit on one line, we can use the concatenation operator (“&”) to join two substrings together. For example:

```
"If a string will not fit on one line, "  
& "then we can break it into parts on separate lines."
```

Bit Strings

VHDL includes values that represent bits (binary digits), which can be either ‘0’ or ‘1’. A bit-string literal represents a sequence of these bit values. It is represented by a string of digits, enclosed by double quotation marks and preceded by a character that specifies the base of the digits. The base specifier can be one of the following:

- B for binary,
- O for octal (base 8) and
- X for hexadecimal (base 16).

For example, some bitstring literals specified in binary are

```
B"0100011" B"10" b"1111_0010_0001" B""
```

Notice that we can include underline characters in bit-string literals to make the literal more readable. The base specifier can be in uppercase or lowercase. The last of the examples above denotes an empty bit string.

If the base specifier is octal, the digits ‘0’ through ‘7’ can be used. Each digit represents exactly three bits in the sequence. Some examples are

```
O"372" -- equivalent to B"011_111_010"  
o"00" -- equivalent to B"000_000"
```

If the base specifier is hexadecimal, the digits ‘0’ through ‘9’ and ‘A’ through ‘F’ or ‘a’ through ‘f’ (representing 10 through 15) can be used. In hexadecimal, each digit represents exactly four bits. Some examples are

```
X"FA" -- equivalent to B"1111_1010"  
x"0d" -- equivalent to B"0000_1101"
```

Syntax Descriptions

In this tutorial, we describe rules of syntax using a notation based on the Extended Backus-Naur Form (EBNF). The idea behind EBNF is to divide the language into *syntactic categories*. For each syntactic category we write a rule that describes how to build a VHDL clause of that category by combining lexical elements and clauses of other categories. We write a rule with the syntactic category we are defining on the

left of a “ \Leftarrow ” sign (read as “is defined to be”), and a pattern on the right. The simplest kind of pattern is a collection of items in sequence, for example:

```
variable_assignment  $\Leftarrow$  target := expression ;
```

This rule indicates that a VHDL clause in the category “variable_assignment” is defined to be a clause in the category “target”, followed by the symbol “:=”, followed by a clause in the category “expression”, followed by the symbol “;”.

The next kind of rule to consider is one that allows for an optional component in a clause. We indicate the optional part by enclosing it between the symbols “[” and “]”. For example:

```
function_call  $\Leftarrow$  name [ ( association_list ) ]
```

This indicates that a function call consists of a name that may be followed by an association list in parentheses. Note the use of the outline symbols for writing the pattern in the rule, as opposed to the normal solid symbols that are lexical elements of VHDL.

In many rules, we need to specify that a clause is optional, but if present, it may be repeated as many times as needed. For example, in this rule:

```
process_statement  $\Leftarrow$ 
    process is
        { process_declarative_item }
    begin
        { sequential_statement }
    end process ;
```

the curly braces specify that a process may include zero or more process declarative items and zero or more sequential statements. A case that arises frequently in the rules of VHDL is a pattern consisting of some category followed by zero or more repetitions of that category. In this case, we use dots within the braces to represent the repeated category, rather than writing it out again in full. For example, the rule

```
case_statement  $\Leftarrow$ 
    case expression is
        case_statement_alternative
        { ... }
    end case ;
```

indicates that a case statement must contain at least one case statement alternative, but may contain an arbitrary number of additional case statement alternatives as required. If there is a sequence of categories and symbols preceding the braces, the dots represent only the last element of the sequence. Thus, in the example above, the dots represent only the case statement alternative, not the sequence “**case** expression **is** case_statement_alternative”.

We also use the dots notation where a list of one or more repetitions of a clause is required, but some delimiter symbol is needed between repetitions. For example, the rule

$$\text{identifier_list} \Leftarrow \text{identifier} \{ , \dots \}$$

specifies that an identifier list consists of one or more identifiers, and that if there is more than one, they are separated by comma symbols. Note that the dots always represent a repetition of the category immediately preceding the left brace symbol. Thus, in the above rule, it is the identifier that is repeated, not the comma.

Many syntax rules allow a category to be composed of one of a number of alternatives, specified using the “|” symbol. For example, the rule

$$\text{mode} \Leftarrow \mathbf{in} \mid \mathbf{out} \mid \mathbf{inout}$$

specifies that the category “mode” can be formed from a clause consisting of one of the reserved words chosen from the alternatives listed.

The final notation we use in our syntax rules is parenthetic grouping, using the symbols “(“ and “)”. These simply serve to group part of a pattern, so that we can avoid any ambiguity that might otherwise arise. For example, the inclusion of parentheses in the rule

$$\text{term} \Leftarrow \text{factor} \{ (* \mid / \mid \mathbf{mod} \mid \mathbf{rem}) \text{factor} \}$$

makes it clear that a factor may be followed by one of the operator symbols, and then another factor.

This EBNF notation is sufficient to describe the complete grammar of VHDL. However, there are often further constraints on a VHDL description that relate to the meaning of the constructs used. To express such constraints, many rules include additional information relating to the meaning of a language feature. For example, the rule shown above describing how a function call is formed is augmented thus:

$$\text{function_call} \Leftarrow \textit{function_name} [(\textit{parameter_association_list})]$$

The italicized prefix on a syntactic category in the pattern simply provides semantic information. This rule indicates that the name cannot be just any name, but must be the name of a function. Similarly, the association list must describe the parameters supplied to the function.

In this tutorial, we will introduce each new feature of VHDL by describing its syntax using EBNF rules, and then we will describe the meaning and use of the feature through examples. In many cases, we will start with a simplified version of the syntax to make the description easier to learn and come back to the full details in a later section.

3.2 Constants and Variables

Constants and variables are objects in which data can be stored for use in a model. The difference between them is that the value of a constant cannot be changed after it is created, whereas a variable’s value can be changed as many times as necessary using variable assignment statements.

Both constants and variables need to be declared before they can be used in a model. A *declaration* simply introduces the name of the object, defines its type and may give it an initial value. The syntax rule for a constant declaration is

```
constant_declaration ←
    constant identifier { , ... } : subtype_indication := expression ;
```

Here are some examples of constant declarations:

```
constant number_of_bytes : integer := 4;
constant number_of_bits : integer := 8 * number_of_bytes;
constant e : real := 2.718281828;
constant prop_delay : time := 3 ns;
constant size_limit, count_limit : integer := 255;
```

The form of a variable declaration is similar to a constant declaration. The syntax rule is

```
variable_declaration ←
    variable identifier { , ... } : subtype_indication [ := expression ] ;
```

The initialization expression is optional; if we omit it, the default initial value assumed by the variable when it is created depends on the type. For scalar types, the default initial value is the leftmost value of the type. For example, for integers it is the smallest representable integer. Some examples of variable declarations are

```
variable index : integer := 0;
variable sum, average, largest : real;
variable start, finish : time := 0 ns;
```

Constant and variable declarations can appear in a number of places in a VHDL model, including in the declaration parts of processes. In this case, the declared object can be used only within the process. One restriction on where a variable declaration may occur is that it may not be placed so that the variable would be accessible to more than one process. This is to prevent the strange effects that might otherwise occur if the processes were to modify the variable in indeterminate order. Once a variable has been declared, its value can be modified by an assignment statement. The syntax of a variable assignment statement is given by the rule

```
variable_assignment_statement ← name := expression ;
```

The name in a variable assignment statement identifies the variable to be changed, and the expression is evaluated to produce the new value. The type of this value must match the type of the variable. Here are some examples of assignment statements:

```
program_counter := 0;
index := index + 1;
```

The first assignment sets the value of the variable `program_counter` to zero, overwriting any previous value. The second example increments the value of `index` by one.

3.3 Scalar Types

A *scalar* type is one whose values are indivisible. In this section, we review VHDL's predefined scalar types. We will also show how to define new enumeration types.

Subtypes

In many models, we want to declare objects that should only take on a restricted range of values. We do so by first declaring a *subtype*, which defines a restricted set of values from a *base type*. The simplified syntax rules for a subtype declaration are

```
subtype_declaration ← subtype identifier is subtype_indication ;
subtype_indication ←
    type_mark range simple_expression ( to | downto ) simple_expression
```

We will look at other forms of subtype indications later. The subtype declaration defines the identifier as a subtype of the base type specified by the type mark, with the range constraint restricting the values for the subtype.

Integer Types

In VHDL, integer types have values that are whole numbers. The predefined type `integer` includes all the whole numbers representable on a particular host computer. The language standard requires that the type `integer` include at least the numbers $-2,147,483,647$ to $+2,147,483,647$ ($-2^{31} + 1$ to $+2^{31} - 1$), but VHDL implementations may extend the range.

There are also two predefined integer subtypes

`natural`, containing the integers from 0 to the largest integer, and

`positive`, containing the integers from 1 to the largest integer.

Where the logic of a design indicates that a number should not be negative, it is good style to use one of these subtypes rather than the base type `integer`. In this way, we can detect any design errors that incorrectly cause negative numbers to be produced.

The operations that can be performed on values of integer types include the familiar arithmetic operations:

<code>+</code>	addition, or unary identity
<code>-</code>	subtraction, or unary negation
<code>*</code>	multiplication
<code>/</code>	division (with truncation)
<code>mod</code>	modulo (same sign as right operand)
<code>rem</code>	remainder (same sign as left operand)
<code>abs</code>	absolute value
<code>**</code>	exponentiation (right operand must be non-negative)

EXAMPLE

Here is a declaration that defines a subtype of `integer`:

```
subtype small_int is integer range -128 to 127;
```

Values of `small_int` are constrained to be within the range -128 to 127. If we declare some variables:

```
variable deviation : small_int;
variable adjustment : integer;
```

we can use them in calculations:

```
deviation := deviation + adjustment;
```

Floating-Point Types

Floating-point types in VHDL are used to represent real numbers with a mantissa part and an exponent part. The predefined floating-point type `real` includes the greatest range allowed by the host's floating-point representation. In most implementations, this will be the range of the IEEE 64-bit double-precision representation.

The operations that can be performed on floating-point values include the arithmetic operations addition and unary identity (“+”), subtraction and unary negation (“-”), multiplication (“*”), division (“/”), absolute value (**abs**) and exponentiation (“**”). For the binary operators (those that take two operands), the operands must be of the same type. The exception is that the right operand of the exponentiation operator must be an integer.

Time

VHDL has a predefined type called `time` that is used to represent simulation times and delays. We can write a time value as a numeric literal followed by a time unit. For example:

```
5 ns 22 us 471.3 msec
```

Notice that we must include a space before the unit name. The valid unit names are

```
fs ps ns us ms sec min hr
```

The type `time` includes both positive and negative values. VHDL also has a redefined subtype of `time`, `delay_length`, that only includes non-negative values.

Many of the arithmetic operators can be applied to `time` values, but with some restrictions. The addition, subtraction, identity and negation operators can be applied to yield results of type `time`. A `time` value can be multiplied or divided by an `integer` or `real` value to yield a `time` value, and two `time` values can be divided to yield an `integer`. For example:

```
18 ns / 2.0 = 9 ns, 33 ns / 22 ps = 1500
```

Finally, the **abs** operator may be applied to a **time** value, for example:

```
abs 2 ps = 2 ps, abs (-2 ps) = 2 ps
```

Enumeration Types

Often when writing models of hardware at an abstract level, it is useful to use a set of names for the encoded values of some signals, rather than committing to a bit-level encoding straightaway. VHDL *enumeration types* allow us to do this. In order to define an enumeration type, we need to use a type declaration. The syntax rule is

```
type_declaration  $\leftarrow$  type identifier is type_definition ;
```

A type declaration allows us to introduce a new type, distinct from other types. One form of type definition is an enumeration type definition. We will see other forms later. The syntax rule for enumeration type definitions is

```
enumeration_type_definition  $\leftarrow$  ( ( identifier | character_literal ) { , ... } )
```

This simply lists all of the values in the type. Each value may be either an identifier or a character literal. An example including only identifiers is

```
type alu_function is (disable, pass, add, subtract, multiply, divide);
```

An example including just character literals is

```
type octal_digit is ('0', '1', '2', '3', '4', '5', '6', '7');
```

Given the above two type declarations, we could declare variables:

```
variable alu_op : alu_function;  
variable last_digit : octal_digit := '0';
```

and make assignments to them:

```
alu_op := subtract;  
last_digit := '7';
```

Characters

The predefined enumeration type **character** includes all of the characters in the ISO 8859 Latin-1 8-bit character set. The type definition is shown in Figure 3-2. It containing a mixture of identifiers (for control characters) and character literals (for graphic characters). The character at position 160 is a non-breaking space character, distinct from the ordinary space character, and the character at position 173 is a soft hyphen.

FIGURE 3-2

```
type character is (  
  nul,      soh,    stx,    etx,    eot,    enq,    ack,    bel,  
  bs,      ht,     lf,     vt,     ff,     cr,     so,     si,  
  dle,     dc1,    dc2,    dc3,    dc4,    nak,    syn,    etb,
```

can,	em,	sub,	esc,	fsp,	gsp,	rsp,	usp,
'\n',	'\t',	'\r',	'\f',	'\a',	'\e',	'\b',	'\c',
'(',	')',	'*',	'+',	';',	'_',	'\:',	'/',
'0',	'1',	'2',	'3',	'4',	'5',	'6',	'7',
'8',	'9',	'\:',	'\;',	'<',	'=',	'>',	'?',
'@',	'A',	'B',	'C',	'D',	'E',	'F',	'G',
'H',	'I',	'J',	'K',	'L',	'M',	'N',	'O',
'P',	'Q',	'R',	'S',	'T',	'U',	'V',	'W',
'X',	'Y',	'Z',	'[',	'\',	']',	'^',	'_',
'\n',	'a',	'b',	'c',	'd',	'e',	'f',	'g',
'h',	'i',	'j',	'k',	'l',	'm',	'n',	'o',
'p',	'q',	'r',	's',	't',	'u',	'v',	'w',
'x',	'y',	'z',	'{',	' ',	'}',	'~',	del,
c128,	c129,	c130,	c131,	c132,	c133,	c134,	c135,
c136,	c137,	c138,	c139,	c140,	c141,	c142,	c143,
c144,	c145,	c146,	c147,	c148,	c149,	c150,	c151,
c152,	c153,	c154,	c155,	c156,	c157,	c158,	c159,
'\u0000',	'\u0001',	'\u0002',	'\u0003',	'\u0004',	'\u0005',	'\u0006',	'\u0007',
'\u0008',	'\u0009',	'\u000a',	'\u000b',	'\u000c',	'\u000d',	'\u000e',	'\u000f',
'\u0010',	'\u0011',	'\u0012',	'\u0013',	'\u0014',	'\u0015',	'\u0016',	'\u0017',
'\u0018',	'\u0019',	'\u001a',	'\u001b',	'\u001c',	'\u001d',	'\u001e',	'\u001f',
'\u0020',	'\u0021',	'\u0022',	'\u0023',	'\u0024',	'\u0025',	'\u0026',	'\u0027',
'\u0028',	'\u0029',	'\u002a',	'\u002b',	'\u002c',	'\u002d',	'\u002e',	'\u002f',
'\u0030',	'\u0031',	'\u0032',	'\u0033',	'\u0034',	'\u0035',	'\u0036',	'\u0037',
'\u0038',	'\u0039',	'\u003a',	'\u003b',	'\u003c',	'\u003d',	'\u003e',	'\u003f',
'\u0040',	'\u0041',	'\u0042',	'\u0043',	'\u0044',	'\u0045',	'\u0046',	'\u0047',
'\u0048',	'\u0049',	'\u004a',	'\u004b',	'\u004c',	'\u004d',	'\u004e',	'\u004f',
'\u0050',	'\u0051',	'\u0052',	'\u0053',	'\u0054',	'\u0055',	'\u0056',	'\u0057',
'\u0058',	'\u0059',	'\u005a',	'\u005b',	'\u005c',	'\u005d',	'\u005e',	'\u005f',
'\u0060',	'\u0061',	'\u0062',	'\u0063',	'\u0064',	'\u0065',	'\u0066',	'\u0067',
'\u0068',	'\u0069',	'\u006a',	'\u006b',	'\u006c',	'\u006d',	'\u006e',	'\u006f',
'\u0070',	'\u0071',	'\u0072',	'\u0073',	'\u0074',	'\u0075',	'\u0076',	'\u0077',
'\u0078',	'\u0079',	'\u007a',	'\u007b',	'\u007c',	'\u007d',	'\u007e',	'\u007f',
'\u0080',	'\u0081',	'\u0082',	'\u0083',	'\u0084',	'\u0085',	'\u0086',	'\u0087',
'\u0088',	'\u0089',	'\u008a',	'\u008b',	'\u008c',	'\u008d',	'\u008e',	'\u008f',
'\u0090',	'\u0091',	'\u0092',	'\u0093',	'\u0094',	'\u0095',	'\u0096',	'\u0097',
'\u0098',	'\u0099',	'\u009a',	'\u009b',	'\u009c',	'\u009d',	'\u009e',	'\u009f',
'\u00a0',	'\u00a1',	'\u00a2',	'\u00a3',	'\u00a4',	'\u00a5',	'\u00a6',	'\u00a7',
'\u00a8',	'\u00a9',	'\u00aa',	'\u00ab',	'\u00ac',	'\u00ad',	'\u00ae',	'\u00af',
'\u00b0',	'\u00b1',	'\u00b2',	'\u00b3',	'\u00b4',	'\u00b5',	'\u00b6',	'\u00b7',
'\u00b8',	'\u00b9',	'\u00ba',	'\u00bb',	'\u00bc',	'\u00bd',	'\u00be',	'\u00bf',
'\u00c0',	'\u00c1',	'\u00c2',	'\u00c3',	'\u00c4',	'\u00c5',	'\u00c6',	'\u00c7',
'\u00c8',	'\u00c9',	'\u00ca',	'\u00cb',	'\u00cc',	'\u00cd',	'\u00ce',	'\u00cf',
'\u00d0',	'\u00d1',	'\u00d2',	'\u00d3',	'\u00d4',	'\u00d5',	'\u00d6',	'\u00d7',
'\u00d8',	'\u00d9',	'\u00da',	'\u00db',	'\u00dc',	'\u00dd',	'\u00de',	'\u00df',
'\u00e0',	'\u00e1',	'\u00e2',	'\u00e3',	'\u00e4',	'\u00e5',	'\u00e6',	'\u00e7',
'\u00e8',	'\u00e9',	'\u00ea',	'\u00eb',	'\u00ec',	'\u00ed',	'\u00ee',	'\u00ef',
'\u00f0',	'\u00f1',	'\u00f2',	'\u00f3',	'\u00f4',	'\u00f5',	'\u00f6',	'\u00f7',
'\u00f8',	'\u00f9',	'\u00fa',	'\u00fb',	'\u00fc',	'\u00fd',	'\u00fe',	'\u00ff',

The definition of the predefined enumeration type character.

To illustrate the use of the `character` type, we declare variables as follows:

```
variable cmd_char, terminator : character;
```

and then make the assignments

```
cmd_char := 'P';
terminator := cr;
```

Booleans

The predefined type `boolean` is defined as

```
type boolean is (false, true);
```

This type is used to represent condition values, which can control execution of a behavioral model. There are a number of operators that we can apply to values of different types to yield Boolean values, namely, the relational and logical operators. The

relational operators equality (“=”) and inequality (“≠”) can be applied to operands of any type, provided both are of the same type. For example, the expressions

```
123 = 123, 'A' = 'A', 7 ns = 7 ns
```

all yield the value **true**, and the expressions

```
123 = 456, 'A' = 'z', 7 ns = 2 us
```

yield the value **false**.

The relational operators that test ordering are the less-than (“<”), less-than-or-equal-to (“<=”), greater-than (“>”) and greater-than-or-equal-to (“>=”) operators. These can only be applied to values of types that are ordered, including all of the scalar types described in this chapter.

The logical operators **and**, **or**, **nand**, **nor**, **xor**, **xnor** and **not** take operands that must be Boolean values, and they produce Boolean results.

Bits

Since VHDL is used to model digital systems, it is useful to have a data type to represent bit values. The predefined enumeration type **bit** serves this purpose. It is defined as

```
type bit is ('0', '1');
```

The logical operators that we mentioned for Boolean values can also be applied to values of type **bit**, and they produce results of type **bit**. The value ‘0’ corresponds to false, and ‘1’ corresponds to true. So, for example:

```
'0' and '1' = '0', '1' xor '1' = '0'
```

The difference between the types **boolean** and **bit** is that **boolean** values are used to model abstract conditions, whereas **bit** values are used to model hardware logic levels. Thus, ‘0’ represents a low logic level and ‘1’ represents a high logic level.

Standard Logic

The IEEE has standardized a package called **std_logic_1164** that allows us to model digital signals taking into account some electrical effects. One of the types defined in this package is an enumeration type called **std_ulogic**, defined as

```
type std_ulogic is ('U',    -- Uninitialized
                    'X',    -- Forcing Unknown
                    '0',    -- Forcing zero
                    '1',    -- Forcing one
                    'Z',    -- High Impedance
                    'W',    -- Weak Unknown
                    'L',    -- Weak zero
                    'H',    -- Weak one
                    '-');  -- Don't care
```

This type can be used to represent signals driven by active drivers (forcing strength), resistive drivers such as pull-ups and pull-downs (weak strength) or three-state drivers including a high-impedance state. Each kind of driver may drive a “zero”, “one” or “unknown” value. An “unknown” value is driven by a model when it is unable to determine whether the signal should be “zero” or “one”. In addition to these values, the leftmost value in the type represents an “uninitialized” value. If we declare signals of `std_ulogic` type, by default they take on ‘U’ as their initial value. The final value in `std_ulogic` is a “don’t care” value. This is sometimes used by logic synthesis tools and may also be used when defining test vectors, to denote that the value of a signal to be compared with a test vector is not important.

Even though the type `std_ulogic` and the other types defined in the `std_logic_1164` package are not actually built into the VHDL language, we can write models as though they were, with a little bit of preparation. For now, we describe some “magic” to include at the beginning of a model that uses the package; we explain the details later. If we include the line

```
library ieee; use ieee.std_logic_1164.all;
```

preceding each entity or architecture body that uses the package, we can write models as though the types were built into the language.

With this preparation in hand, we can now create constants, variables and signals of type `std_ulogic`. As well as assigning values of the type, we can also use the logical operators **and**, **or**, **not** and so on. Each of these operates on `std_ulogic` values and returns a `std_ulogic` result of ‘U’, ‘X’, ‘0’ or ‘1’.

3.4 Sequential Statements

In this section we look at how data may be manipulated within processes using *sequential statements*, so called because they are executed in sequence. We have already seen one of the basic sequential statements, the variable assignment statement. The statements we look at in this section deal with controlling actions within a model; hence they are often called control structures. They allow selection between alternative courses of action as well as repetition of actions.

If Statements

In many models, the behavior depends on a set of conditions that may or may not hold true during the course of simulation. We can use an *if statement* to express this behavior. The syntax rule for an if statement is

```
if_statement ←
  [ if_label : ]
  if boolean_expression then
    { sequential_statement }
  { elsif boolean_expression then
    { sequential_statement } }
  [ else
```

```

    { sequential_statement } ]
end if [ if_label ] ;

```

A simple example of an if statement is

```

if en = '1' then
    stored_value := data_in;
end if;

```

The Boolean expression after the keyword **if** is the condition that is used to control whether or not the statement after the keyword **then** is executed. If the condition evaluates to true, the statement is executed. We can also specify actions to be performed if the condition is false. For example:

```

if sel = 0 then
    result <= input_0;    -- executed if sel = 0
else
    result <= input_1;    -- executed if sel /= 0
end if;

```

Here, as the comments indicate, the first signal assignment statement is executed if the condition is true, and the second signal assignment statement is executed if the condition is false.

We can construct a more elaborate form of if statement to check a number of different conditions, for example:

```

if mode = immediate then
    operand := immed_operand;
elsif opcode = load or opcode = add or opcode = subtract then
    operand := memory_operand;
else
    operand := address_operand;
end if;

```

In general, we can construct an if statement with any number of **elsif** clauses (including none), and we may include or omit the **else** clause. Execution of the if statement starts by evaluating the first condition. If it is false, successive conditions are evaluated, in order, until one is found to be true, in which case the corresponding statements are executed. If none of the conditions is true, and we have included an **else** clause, the statements after the **else** keyword are executed.

EXAMPLE

A heater thermostat can be modeled as an entity with two integer inputs, one that specifies the desired temperature and another that is connected to a thermometer, and one Boolean output that turns a heater on and off. The thermostat turns the heater on if the measured temperature falls below two degrees less than the desired temperature, and turns the heater off if the measured temperature rises above two degrees greater than the desired temperature.

Figure 3-3 shows the entity and architecture bodies for the thermostat. The entity declaration defines the input and output ports. The process in the architecture body includes the input ports in the *sensitivity list* after the keyword **process**. This is a list of signals to which the process is sensitive. When any of these signals changes value, the process resumes and executes the sequential statements. After it has executed the last statement, the process suspends again. The if statement compares the actual temperature with the desired temperature and turns the heater on or off as required.

FIGURE 3-3

```

entity thermostat is
  port ( desired_temp, actual_temp : in integer;
         heater_on : out boolean );
end entity thermostat;
-----
architecture example of thermostat is
begin
  controller : process (desired_temp, actual_temp) is
  begin
    if actual_temp < desired_temp - 2 then
      heater_on <= true;
    elsif actual_temp > desired_temp + 2 then
      heater_on <= false;
    end if;
  end process controller;
end architecture example;

```

An entity and architecture body for a heater thermostat.

Case Statements

If we have a model in which the behavior is to depend on the value of a single expression, we can use a *case statement*. The syntax rules are as follows:

```

case_statement <=
  [ case_label : ]
  case expression is
    ( when choices => { sequential_statement } )
    { ... }
  end case [ case_label ] ;
choices <= ( simple_expression | discrete_range | others ) { | ... }

```

For example, suppose we are modeling an arithmetic/logic unit, with a control input, func, declared to be of the enumeration type:

```

type alu_func is (pass1, pass2, add, subtract);

```

We could describe the behavior using a case statement:

```

case func is
  when pass1 =>
    result := operand1;
  when pass2 =>
    result := operand2;
  when add =>
    result := operand1 + operand2;
  when subtract =>
    result := operand1 - operand2;
end case;

```

At the head of this case statement is the *selector expression*, between the keywords **case** and **is**. The value of this expression is used to select which statements to execute. The body of the case statement consists of a series of *alternatives*. Each alternative starts with the keyword **when** and is followed by one or more *choices* and a sequence of statements. The choices are values that are compared with the value of the selector expression. There must be exactly one choice for each possible value. The case statement finds the alternative whose choice value is equal to the value of the selector expression and executes the statements in that alternative.

We can include more than one choice in each alternative by writing the choices separated by the “|” symbol. For example, if the type **opcodes** is declared as

```

type opcodes is
  (nop, add, subtract, load, store, jump, jumpsub, branch, halt);

```

we could write an alternative including three of these values as choices:

```

when load | add | subtract =>
  operand := memory_operand;

```

If we have a number of alternatives in a case statement and we want to include an alternative to handle all possible values of the selector expression not mentioned in previous alternatives, we can use the special choice **others**. For example, if the variable **opcode** is a variable of type **opcodes**, declared above, we can write

```

case opcode is
  when load | add | subtract =>
    operand := memory_operand;
  when store | jump | jumpsub | branch =>
    operand := address_operand;
  when others =>
    operand := 0;
end case;

```

In this example, if the value of **opcode** is anything other than the choices listed in the first and second alternatives, the last alternative is selected. There may only be one alternative that uses the **others** choice, and if it is included, it must be the last alternative in the case statement. An alternative that includes the **others** choice may not include any other choices.

An important point to note about the choices in a case statement is that they must all be written using *locally static* values. This means that the values of the choices must be determined during the analysis phase of design processing.

EXAMPLE

We can write a behavioral model of a branch-condition multiplexer with a select input **sel**; two condition code inputs **cc_z** and **cc_c**; and an output **taken**. The condition code inputs and outputs are of the IEEE standard-logic type, and the select input is of type **branch_fn**, which we assume to be declared elsewhere as

```
type branch_fn is (br_z, br_nz, br_c, br_nc);
```

We will see later how we define a type for use in an entity declaration. The entity declaration defining the ports and a behavioral architecture body are shown in Figure 3-4. The architecture body contains a process that is sensitive to the inputs. It makes use of a case statement to select the value to assign to the output.

FIGURE 3-4

```
library ieee; use ieee.std_logic_1164.all;
entity cond_mux is
  port ( sel : in branch_fn;
         cc_z, cc_c : in std_ulogic;
         taken : out std_ulogic );
end entity cond_mux;

-----

architecture demo of cond_mux is
begin
  out_select : process (sel, cc_z, cc_c) is
  begin
    case sel is
      when br_z =>
        taken <= cc_z;
      when br_nz =>
        taken <= not cc_z;
      when br_c =>
        taken <= cc_c;
      when br_nc =>
        taken <= not cc_c;
    end case;
  end process out_select;
end architecture demo;
```

An entity and architecture body for a branch condition multiplexer.

Loop and Exit Statements

Often we need to write a sequence of statements that is to be repeatedly executed. We use a *loop statement* to express this behavior. The syntax rule for a simple loop that iterates indefinitely is

```
loop_statement ←
  [ loop_label : ]
  loop
    { sequential_statement }
  end loop [ loop_label ] ;
```

Usually we need to exit the loop when some condition arises. We can use an *exit statement* to exit a loop. The syntax rule is

```
exit_statement ←
  [ label : ] exit [ loop_label ] [ when boolean_expression ] ;
```

The simplest form of exit statement is just

```
exit;
```

When this statement is executed, any remaining statements in the loop are skipped, and control is transferred to the statement after the **end loop** keywords. So in a loop we can write

```
if condition then
  exit;
end if;
```

where *condition* is a Boolean expression. Since this is perhaps the most common use of the exit statement, VHDL provides a shorthand way of writing it, using the **when** clause. We use an exit statement with the **when** clause in a loop of the form

```
loop
  ...
  exit when condition;
  ...
end loop;
...      -- control transferred to here
         -- when condition becomes true within the loop
```

EXAMPLE

Figure 3-5 is a model for a counter that starts from zero and increments on each clock transition from '0' to '1'. When the counter reaches 15, it wraps back to zero on the next clock transition. The counter has an asynchronous **reset** input that, when '1', causes the **count** output to be reset to zero. The output stays at zero as long as the **reset** input is '1' and resumes counting on the next clock transition after **reset** changes to '0'.

FIGURE 3-5

```

entity counter is
  port ( clk, reset : in bit; count : out natural );
end entity counter;
-----
architecture behavior of counter is
begin
  incrementer : process is
    variable count_value : natural := 0;
  begin
    count <= count_value;
    loop
      loop
        wait until clk = '1' or reset = '1';
        exit when reset = '1';
        count_value := (count_value + 1) mod 16;
        count <= count_value;
      end loop;
      -- at this point, reset = '1'
      count_value := 0;
      count <= count_value;
      wait until reset = '0';
    end loop;
  end process incrementer;
end architecture behavior;

```

An entity and architecture body of the revised counter, including a reset input.

The architecture body contains two nested loops. The inner loop deals with normal counting operation. When **reset** changes to '1', the exit statement causes the inner loop to be terminated. Control is transferred to the statement just after the end of the inner loop. The count value and **count** outputs are reset, and the process then waits for **reset** to return to '0', after which the process resumes and the outer loop repeats.

In some cases, we may wish to transfer control out of an inner loop and also a containing loop. We can do this by labeling the outer loop and using the label in the exit statement. We can write

```

loop_name : loop
  ...
  exit loop_name;
  ...
end loop loop_name ;

```

This labels the loop with the name `loop_name`, so that we can indicate which loop to exit in the exit statement. The loop label can be any valid identifier. The exit statement referring to this label can be located within nested loop statements.

While Loops

We can augment the basic loop statement introduced previously to form a *while loop*, which tests a condition before each iteration. If the condition is true, iteration proceeds. If it is false, the loop is terminated. The syntax rule for a while loop is

```
loop_statement ←
  [ loop_label : ]
  while boolean_expression loop
    { sequential_statement }
  end loop [ loop_label ] ;
```

The only difference between this form and the basic loop statement is that we have added the keyword **while** and the condition before the **loop** keyword. All of the things we said about the basic loop statement also apply to a while loop. The condition is tested before each iteration of the while loop, including the first iteration. This means that if the condition is false before we start the loop, it is terminated immediately, with no iterations being executed.

EXAMPLE

We can develop a model for an entity `cos` that calculates the cosine function of an input `theta` using the relation

$$\cos\theta = 1 - \frac{\theta^2}{2!} + \frac{\theta^4}{4!} - \frac{\theta^6}{6!} + \dots$$

We add successive terms of the series until the terms become smaller than one millionth of the result. The entity and architecture body declarations are shown in Figure 3-6. The cosine function is computed using a while loop that increments `n` by two and uses it to calculate the next term based on the previous term. Iteration proceeds as long as the last term computed is larger in magnitude than one millionth of the sum. When the last term falls below this threshold, the while loop is terminated.

FIGURE 3-6

```
entity cos is
  port ( theta : in real; result : out real );
end entity cos;
```

```
architecture series of cos is
begin
```

```

summation : process (theta) is
  variable sum, term : real;
  variable n : natural;
begin
  sum := 1.0;
  term := 1.0;
  n := 0;
  while abs term > abs (sum / 1.0E6) loop
    n := n + 2;
    term := (-term) * theta**2 / real(((n-1) * n));
    sum := sum + term;
  end loop;
  result <= sum;
end process summation;
end architecture series;

```

An entity and architecture body for a cosine module.

For Loops

Another way we can augment the basic loop statement is the *for loop*. A for loop includes a specification of how many times the body of the loop is to be executed. The syntax rule for a for loop is

```

loop_statement ←
  [ loop_label : ]
  for identifier in discrete_range loop
    { sequential_statement }
  end loop [ loop_label ];

```

A discrete range can be of the form

```
simple_expression ( to | downto ) simple_expression
```

representing all the values between the left and right bounds, inclusive. The identifier is called the *loop parameter*, and for each iteration of the loop, it takes on successive values of the discrete range, starting from the left element. For example, in this for loop:

```

for count_value in 0 to 127 loop
  count_out <= count_value;
  wait for 5 ns;
end loop;

```

the identifier `count_value` takes on the values 0, 1, 2 and so on, and for each value, the assignment and wait statements are executed. Thus the signal `count_out` will be assigned values 0, 1, 2 and so on, up to 127, at 5 ns intervals.

Within the sequence of statements in the for loop body, the loop parameter is a constant. This means we can use its value by including it in an expression, but we

cannot make assignments to it. Unlike other constants, we do not need to declare it. Instead, the loop parameter is implicitly declared over the for loop. It only exists when the loop is executing, and not before or after it.

Like basic loop statements, for loops can enclose arbitrary sequential statements, including exit statements, and we can label a for loop by writing the label before the **for** keyword.

EXAMPLE

We now rewrite the cosine model in Figure 3-6 to calculate the result by summing the first 10 terms of the series with a for loop. The entity declaration is unchanged. The revised architecture body is shown in Figure 3-7.

FIGURE 3-7

```

architecture fixed_length_series of cos is
begin
  summation : process (theta) is
    variable sum, term : real;
  begin
    sum := 1.0;
    term := 1.0;
    for n in 1 to 9 loop
      term := (-term) * theta**2 / real(((2*n-1) * 2**n));
      sum := sum + term;
    end loop;
    result <= sum;
  end process summation;
end architecture fixed_length_series;

```

The revised architecture body for the cosine module.

Assertion Statements

One of the reasons for writing models of computer systems is to verify that a design functions correctly. We can partially test a model by applying sample inputs and checking that the outputs meet our expectations. If they do not, we are then faced with the task of determining what went wrong inside the design. This task can be made easier using *assertion statements* that check that expected conditions are met within the model. An assertion statement is a sequential statement, so it can be included anywhere in a process body. The syntax rule for an assertion statement is

```

assertion_statement <=
  assert boolean_expression
  [ report expression ] [ severity expression ] ;

```

The simplest form of assertion statement just includes the keyword **assert** followed by a Boolean expression that we expect to be true when the assertion state-

ment is executed. If the condition is not met, we say that an *assertion violation* has occurred. If an assertion violation arises during simulation of a model, the simulator reports the fact. For example, if we write

```
assert initial_value <= max_value;
```

and `initial_value` is larger than `max_value` when the statement is executed during simulation, the simulator will let us know.

We can get the simulator to provide extra information by including a **report** clause in an assertion statement, for example:

```
assert initial_value <= max_value
report "initial value too large";
```

The string that we provide is used to form part of the assertion violation message.

VHDL predefines an enumeration type `severity_level`, defined as

```
type severity_level is (note, warning, error, failure);
```

We can include a value of this type in a **severity** clause of an assertion statement. This value indicates the degree to which the violation of the assertion affects operation of the model. Some example are:

```
assert packet_length /= 0
report "empty network packet received"
severity warning;
assert clock_pulse_width >= min_clock_width
severity error;
```

If we omit the **report** clause, the default string in the error message is “Assertion violation.” If we omit the **severity** clause, the default value is **error**. The severity value is usually used by a simulator to determine whether or not to continue execution after an assertion violation. Most simulators allow the user to specify a severity threshold, beyond which execution is stopped.

EXAMPLE

An important use for assertion statements is in checking timing constraints that apply to a model. For example, in an edge-triggered register, when the clock changes from ‘0’ to ‘1’, the data input is sampled, stored and transmitted through to the output. Let us suppose that the clock input must remain at ‘1’ for at least 5 ns. Figure 3-8 is a model for a register that includes a check for legal clock pulse width.

FIGURE 3-8

```
entity edge_triggered_register is
port ( clock : in bit;
        d_in : in real; d_out : out real );
end entity edge_triggered_register;
```

```

architecture check_timing of edge_triggered_register is
begin
    store_and_check : process (clock) is
        variable stored_value : real;
        variable pulse_start : time;
    begin
        case clock is
            when '1' =>
                pulse_start := now;
                stored_value := d_in;
                d_out <= stored_value;
            when '0' =>
                assert now = 0 ns or (now – pulse_start) >= 5 ns
                report "clock pulse too short";
        end case;
    end process store_and_check;
end architecture check_timing;

```

An entity and architecture body for an edge-triggered register, including a timing check for correct pulse width on the clock input.

The architecture body contains a process that is sensitive to changes on the clock input. When the clock changes from '0' to '1', the input is stored, and the current simulation time, accessed using the predefined function `now`, is recorded in the variable `pulse_start`. When the clock changes from '1' to '0', the difference between `pulse_start` and the current simulation time is checked by the assertion statement.

3.5 Array Types and Operations

An *array* consists of a collection of values, all of which are of the same type as each other. The position of each element in an array is given by a scalar value called its *index*. To create an array object in a model, we first define an array type in a type declaration. The syntax rule for an array type definition is

```

array_type_definition <=
    array ( discrete_range ) of element_subtype_indication

```

This defines an array type by specifying the index range and the element type or subtype. A discrete range is a subset of values from a discrete type (an integer or enumeration type). It can be specified as shown by the simplified syntax rule

```

discrete_range <=
    type_mark
    | simple_expression ( to | downto ) simple_expression

```

We illustrate these rules for defining arrays with a series of examples. Here is a simple example to start off with, showing the declaration of an array type to represent words of data:

type word is array (0 to 31) of bit;

Each element is a bit, and the elements are indexed from 0 up to 31. An alternative declaration of a word type, more appropriate for “little-endian” systems, is

type word is array (31 downto 0) of bit;

The difference here is that index values start at 31 for the leftmost element in values of this type and continue down to 0 for the rightmost. The index values of an array do not have to be numeric. For example, given this declaration of an enumeration type:

type controller_state is (initial, idle, active, error);

we could then declare an array as follows:

type state_counts is array (idle to error) of natural;

If we need an array element for every value in an index type, we need only name the index type in the array declaration without specifying the range. For example:

subtype coeff_ram_address is integer range 0 to 63;
type coeff_array is array (coeff_ram_address) of real;

Once we have declared an array type, we can define objects of that type, including constants, variables and signals. For example, using the types declared above, we can declare variables as follows:

variable buffer_register, data_register : word;
variable counters : state_counts;
variable coeff : coeff_array;

Each of these objects consists of the collection of elements described by the corresponding type declaration. An individual element can be used in an expression or as the target of an assignment by referring to the array object and supplying an index value, for example:

coeff(0) := 0.0;

If **active** is a variable of type **controller_state**, we can write

counters(active) := counters(active) + 1;

An array object can also be used as a single composite object. For example, the assignment

data_register := buffer_register;

copies all of the elements of the array `buffer_register` into the corresponding elements of the array `data_register`.

Array Aggregates

Often we also need to write literal array values, for example, to initialize a variable or constant of an array type. We can do this using a VHDL construct called an array *aggregate*, according to the syntax rule

$$\text{aggregate} \leftarrow (([\text{choices} \Rightarrow] \text{expression}) \{ , \dots \})$$

Let us look first at the form of aggregate without the choices part. It simply consists of a list of the elements enclosed in parentheses, for example:

```
type point is array (1 to 3) of real;
constant origin : point := (0.0, 0.0, 0.0);
variable view_point : point := (10.0, 20.0, 0.0);
```

This form of array aggregate uses *positional association* to determine which value in the list corresponds to which element of the array. The first value is the element with the leftmost index, the second is the next index to the right, and so on, up to the last value, which is the element with the rightmost index. There must be a one-to-one correspondence between values in the aggregate and elements in the array.

An alternative form of aggregate uses *named association*, in which the index value for each element is written explicitly using the choices part shown in the syntax rule. The choices may be specified in exactly the same way as those in alternatives of a case statement. For example, the variable declaration and initialization could be rewritten as

```
variable view_point : point := (1 => 10.0, 2 => 20.0, 3 => 0.0);
```

EXAMPLE

Figure 3-9 is a model for a memory that stores 64 real-number coefficients, initialized to 0.0. We assume the type `coeff_ram_address` is previously declared as above. The architecture body contains a process with an array variable representing the coefficient storage. The array is initialized using an aggregate in which all elements are 0.0. The process is sensitive to all of the input ports. When `rd` is '1', the array is indexed using the address value to read a coefficient. When `wr` is '1', the address value is used to select which coefficient to change.

FIGURE 3-9

```
entity coeff_ram is
  port ( rd, wr : in bit; addr : in coeff_ram_address;
         d_in : in real; d_out : out real );
end entity coeff_ram;
```

```
-----
architecture abstract of coeff_ram is
begin
```

```

memory : process (rd, wr, addr, d_in) is
    type coeff_array is array (coeff_ram_address) of real;
    variable coeff : coeff_array := (others => 0.0);
begin
    if rd = '1' then
        d_out <= coeff(addr);
    end if;
    if wr = '1' then
        coeff(addr) := d_in;
    end if;
end process memory;
end architecture abstract;

```

An entity and architecture body for a memory module that stores real-number coefficients. The memory storage is implemented using an array.

Array Attributes

VHDL provides a number of *attributes* to refer to information about the index ranges of array types and objects. Attributes are written by following the array type or object name with the symbol `'` and the attribute name. Given some array type or object `A`, and an integer `N` between 1 and the number of dimensions of `A`, VHDL defines the following attributes:

<code>A'left</code>	Left bound of index range of <code>A</code>
<code>A'right</code>	Right bound of index range of <code>A</code>
<code>A'range</code>	Index range of <code>A</code>
<code>A'reverse_range</code>	Reverse of index range of <code>A</code>
<code>A'length</code>	Length of index range of <code>A</code>

For example, given the array declaration

```
type A is array (1 to 4) of boolean;
```

some attribute values are

```

A'left = 1
A'right = 4
A'range is 1 to 4
A'length = 4
A'reverse_range is 4 downto 1

```

The attributes can be used when writing for loops to iterate over elements of an array. For example, given an array variable `free_map` that is an array of bits, we can write a for loop to count the number of `'1'` bits without knowing the actual size of the array:

```

count := 0;
for index in free_map'range loop
    if free_map(index) = '1' then

```

```

        count := count + 1;
    end if;
end loop;

```

The `'range` and `'reverse_range` attributes can be used in any place in a VHDL model where a range specification is required, as an alternative to specifying the left and right bounds and the range direction. Thus, we may use the attributes in type and subtype definitions, in subtype constraints, in for loop parameter specifications, in case statement choices and so on. The advantage of taking this approach is that we can specify the size of the array in one place in the model and in all other places use array attributes. If we need to change the array size later for some reason, we need only change the model in one place.

Unconstrained Array Types

The array types we have seen so far in this chapter are called *constrained* arrays, since the type definition constrains index values to be within a specific range. VHDL also allows us to define *unconstrained* array types, in which we just indicate the type of the index values, without specifying bounds. An unconstrained array type definition is described by the alternate syntax rule

```

array_type_definition ←
    array ( type_mark range <> ) of element_subtype_indication

```

The symbol “<>”, often called “box,” can be thought of as a placeholder for the index range, to be filled in later when the type is used. An example of an unconstrained array type declaration is

```

type sample is array (natural range <>) of integer;

```

An important point to understand about unconstrained array types is that when we declare an object of such a type, we need to provide a constraint that specifies the index bounds. We can do this in several ways. One way is to provide the constraint when an object is created, for example:

```

variable short_sample_buf : sample(0 to 63);

```

This indicates that index values for the variable `short_sample_buf` are natural numbers in the ascending range 0 to 63. Another way to specify the constraint is to declare a subtype of the unconstrained array type. Objects can then be created using this subtype, for example:

```

subtype long_sample is sample(0 to 255);
variable new_sample_buf, old_sample_buf : long_sample;

```

These are both examples of a new form of subtype indication that we have not yet seen. The syntax rule is

```

subtype_indication ← type_mark [ ( discrete_range ) ]

```

The type mark is the name of the unconstrained array type, and the discrete range specifications constrain the index type to a subset of values used to index array elements.

Strings

VHDL provides a predefined unconstrained array type called `string`, declared as

```
type string is array (positive range <>) of character;
```

For example:

```
constant LCD_display_len : positive := 20;
subtype LCD_display_string is string(1 to LCD_display_len);
variable LCD_display : LCD_display_string := (others => '');
```

Bit Vectors

VHDL also provides a predefined unconstrained array type called `bit_vector`, declared as

```
type bit_vector is array (natural range <>) of bit;
```

For example, subtypes for representing bytes of data in a little-endian processor might be declared as

```
subtype byte is bit_vector(7 downto 0);
```

Alternatively, we can supply the constraint when an object is declared, for example:

```
variable channel_busy_register : bit_vector(1 to 4);
```

Standard-Logic Arrays

The standard-logic package `std_logic_1164` provides an unconstrained array type for vectors of standard-logic values. It is declared as

```
type std_ulogic_vector is array ( natural range <> ) of std_ulogic;
```

We can define subtypes of the standard-logic vector type, for example:

```
subtype std_ulogic_word is std_ulogic_vector(0 to 31);
```

Or we can directly create an object of the standard-logic vector type:

```
signal csr_offset : std_ulogic_vector(2 downto 1);
```

Unconstrained Array Ports

An important use of an unconstrained array type is to specify the type of an array port. This use allows us to write an entity interface in a general way, so that it can connect to array signals of any size or with any range of index values. When we instantiate

the entity, the index bounds of the array signal connected to the port are used as the bounds of the port.

EXAMPLE

Suppose we wish to model a family of and gates, each with a different number of inputs. We declare the entity interface as shown in Figure 3-10. The input port is of the unconstrained type `bit_vector`. The process in the architecture body performs a logical and operation across the input array. It uses the `range` attribute to determine the index range of the array, since the index range is not known until the entity is instantiated.

FIGURE 3-10

```

entity and_multiple is
  port ( i : in bit_vector; y : out bit );
end entity and_multiple;
-----
architecture behavioral of and_multiple is
begin
  and_reducer : process ( i ) is
    variable result : bit;
  begin
    result := '1';
    for index in i'range loop
      result := result and i(index);
    end loop;
    y <= result;
  end process and_reducer;
end architecture behavioral;

```

An entity and architecture body for an and gate with an unconstrained array input port.

To illustrate the use of the multiple-input gate entity, suppose we have the following signals:

```

signal count_value : bit_vector(7 downto 0);
signal terminal_count : bit;

```

We instantiate the entity, connecting its input port to the bit-vector signal:

```

tc_gate : entity work.and_multiple(behavioral)
  port map ( i => count_value, y => terminal_count);

```

For this instance, the input port is constrained by the index range of the signal. The instance acts as an eight-input and gate.

Array Operations and Referencing

VHDL provides a number of operators to operate on whole arrays, combining elements in a pairwise fashion. First, the logical operators (**and**, **or**, **nand**, **nor**, **xor** and **xnor**) can be applied to two one-dimensional arrays of bit or Boolean elements, and the operator **not** can be applied to a single array of bit or Boolean elements. The following declarations and statements illustrate this use of logical operators when applied to bit vectors:

```
subtype pixel_row is bit_vector (0 to 15);
variable current_row, mask : pixel_row;
current_row := current_row and not mask;
current_row := current_row xor X"FFFF";
```

Second, the shift operators can be used with a one-dimensional array of bit or Boolean values as the left operand and an integer value as the right operand. The operators are:

sll	shift left logical
srl	shift right logical
sla	shift left arithmetic
sra	shift right arithmetic
rol	rotate left
ror	rotate right

Third, relational operators can be applied to arrays of any discrete element type. The two operands need not be of the same length, so long as they have the same element type. Elements are compared pairwise left-to-right until a pair is found that are unequal or the end of one or other operand is reached. For example, when applied to character strings, the relational operators test according to dictionary ordering.

Finally, the concatenation operator (“&”) joins two array values end to end. For example, `b"0000" & b"1111"` produces `b"0000_1111"`. The concatenation operator can also be applied to two operands, one of which is an array and the other of which is a single scalar element, or to two scalar values to produce an array of length 2. Some examples are

```
"abc" & 'd' = "abcd"
'w' & "xyz" = "wxyz"
'a' & 'b' = "ab"
```

Array Slices

Often we want to refer to a contiguous subset of elements of an array, but not the whole array. We can do this using *slice* notation, in which we specify the left and right index values of part of an array object. For example, given arrays `a1` and `a2` declared as follows:

```
type array1 is array (1 to 100) of integer;  
type array2 is array (100 downto 1) of integer;  
variable a1 : array1;  
variable a2 : array2;
```

we can refer to the array slice `a1(11 to 20)`, which is an array of 10 elements having the indices 11 to 20. Similarly, the slice `a2(50 downto 41)` is an array of 10 elements but with a descending index range.

4

Basic Modeling Constructs

4.1 Entity Declarations

Let us first examine the syntax rules for an entity declaration and then show some examples. The syntax rules are

```
entity_declaration ←
    entity identifier is
        [ port ( port_interface_list ) ; ]
    end [ entity ] [ identifier ] ;
interface_list ←
    ( identifier { , ... } : [ mode ] subtype_indication ) { ; ... }
mode ← in | out | inout
```

The identifier in an entity declaration names the module so that it can be referred to later. If the identifier is included at the end of the declaration, it must repeat the name of the entity. The port clause names each of the *ports*, which together form the interface to the entity. We can think of ports as being analogous to the pins of a circuit; they are the means by which information is fed into and out of the circuit. In VHDL, each port of an entity has a *type*, which specifies the kind of information that can be communicated, and a *mode*, which specifies whether information flows into or out from the entity through the port. A simple example of an entity declaration is

```
entity adder is
    port ( a, b : in word;
          sum : out word );
end entity adder;
```

This example describes an entity named **adder**, with two input ports and one output port, all of type **word**, which we assume is defined elsewhere. We can list the ports in any order; we do not have to put inputs before outputs.

In this example we have input and output ports. We can also have bidirectional ports, with mode **inout**, to model devices that alternately sense and drive data through a pin. Such models must deal with the possibility of more than one connected device driving a given signal at the same time. VHDL provides a mechanism for this, *signal resolution*, which we will return to later.

Note that the port clause is optional. So we can write an entity declaration such as

```

entity top_level is
end entity top_level;

```

which describes a completely self-contained module. As the name in this example implies, this kind of module usually represents the top level of a design hierarchy.

4.2 Architecture Bodies

The internal operation of a module is described by an architecture body. An architecture body generally applies some operations to values on input ports, generating values to be assigned to output ports. The operations can be described either by processes, which contain sequential statements operating on values, or by a collection of components representing sub-circuits. Where the operation requires generation of intermediate values, these can be described using *signals*, analogous to the internal wires of a module. The syntax rule for architecture bodies shows the general outline:

```

architecture_body ←
  architecture identifier of entity_name is
    { block_declarative_item }
  begin
    { concurrent_statement }
  end [ architecture ] [ identifier ] ;

```

The identifier names this particular architecture body, and the entity name specifies which module has its operation described by this architecture body. If the identifier is included at the end of the architecture body, it must repeat the name of the architecture body. There may be several different architecture bodies corresponding to a single entity, each describing an alternative way of implementing the module's operation. The block declarative items in an architecture body are declarations needed to implement the operations. The items may include type and constant declarations, signal declarations and other kinds of declarations that we will look at in later chapters.

The *concurrent statements* in an architecture body describe the module's operation. One form of concurrent statement, which we have already seen, is a process statement. We have looked at processes first because they are the most fundamental form of concurrent statement. All other forms can ultimately be reduced to one or more processes. Concurrent statements are so called because conceptually they can be activated and perform their actions together, that is, concurrently. Contrast this with the sequential statements inside a process, which are executed one after another. Concurrency is useful for modeling the way real circuits behave.

When we need to provide internal signals in an architecture body, we must define them using *signal declarations*. The syntax for a signal declaration is very similar to that for a variable declaration:

```

signal_declaration ←
  signal identifier { , ... } : subtype_indication [ := expression ] ;

```

This declaration simply names each signal, specifies its type and optionally includes an initial value for all signals declared by the declaration.

An important point that we mentioned earlier is that the ports of the entity are also visible to processes inside the architecture body and are used in the same way as signals. This corresponds to our view of ports as external pins of a circuit: from the internal point of view, a pin is just a wire with an external connection. So it makes sense for VHDL to treat ports like signals inside an architecture of the entity.

4.3 Behavioral Descriptions

At the most fundamental level, the behavior of a module is described by signal assignment statements within processes. We can think of a process as the basic unit of behavioral description. A process is executed in response to changes of values of signals and uses the present values of signals it reads to determine new values for other signals. A signal assignment is a sequential statement and thus can only appear within a process. In this section, we look in detail at the interaction between signals and processes.

Signal Assignment

In all of the examples we have looked at so far, we have used a simple form of signal assignment statement. Each assignment just provides a new value for a signal. What we have not yet addressed is the issue of timing: when does the signal take on the new value? This is fundamental to modeling hardware, in which events occur over time. First, let us look at the syntax for a basic signal assignment statement in a process:

```
signal_assignment_statement <=
    name <= ( value_expression [ after time_expression ] ) { , ... } ;
```

The syntax rule tells us that we can specify one or more expressions, each with an optional delay time. It is these delay times in a signal assignment that allow us to specify when the new value should be applied. For example, consider the following assignment:

```
y <= not or_a_b after 5 ns;
```

This specifies that the signal *y* is to take on the new value at a time 5 ns later than that at which the statement executes. Thus, if the above assignment is executed at time 250 ns, and *or_a_b* has the value '1' at that time, then the signal *y* will take on the value '0' at time 255 ns. Note that the statement itself executes in zero modeled time.

The time dimension referred to when the model is executed is *simulation time*, that is, the time in which the circuit being modeled is deemed to operate. We measure simulation time starting from zero at the start of execution and increasing in discrete steps as events occur in the model. A simulator must have a simulation time clock, and when a signal assignment statement is executed, the delay specified is added to the current simulation time to determine when the new value is to be applied to the signal. We say that the signal assignment schedules a *transaction* for the signal,

where the transaction consists of the new value and the simulation time at which it is to be applied. When simulation time advances to the time at which a transaction is scheduled, the signal is updated with the new value. We say that the signal is *active* during that simulation cycle. If the new value is not equal to the old value it replaces on a signal, we say an *event* occurs on the signal. The importance of this distinction is that processes respond to events on signals, not to transactions.

The syntax rules for signal assignments show that we can schedule a number of transactions for a signal, to be applied after different delays. For example, a clock driver process might execute the following assignment to generate the next two edges of a clock signal (assuming T_{pw} is a constant that represents the clock pulse width):

```
clk <= '1' after T_pw, '0' after 2*T_pw;
```

If this statement is executed at simulation time 50 ns and T_{pw} has the value 10 ns, one transaction is scheduled for time 60 ns to set `clk` to '1', and a second transaction is scheduled for time 70 ns to set `clk` to '0'. If we assume that `clk` has the value '0' when the assignment is executed, both transactions produce events on `clk`.

EXAMPLE

We can write a process that models a two-input multiplexer as shown in Figure 4-1. The value of the `sel` port is used to select which signal assignment to execute to determine the output value.

FIGURE 4-1

```

mux : process (a, b, sel) is
begin
  case sel is
    when '0' =>
      z <= a after prop_delay;
    when '1' =>
      z <= b after prop_delay;
  end case;
end process mux;

```

A process that models a two-input multiplexer.

We say that a process defines a *driver* for a signal if and only if it contains at least one signal assignment statement for the signal. If a process contains signal assignment statements for several signals, it defines drivers for each of those signals. A driver is a *source* for a signal in that it provides values to be applied to the signal. An important rule to remember is that for normal signals, there may only be one source. This means that we cannot write two different processes each containing signal assignment statements for the one signal. If we want to model such things as buses or wired-or signals, we must use a special kind of signal called a *resolved signal*, which we will discuss later.

Signal Attributes

VHDL provides a number of attributes for signals to find information about their history of transactions and events. Given a signal **S**, and a value **T** of type **time**, VHDL defines the following attributes:

S'delayed(T)	A signal that takes on the same values as S but is delayed by time T .
S'event	True if there is an event on S in the current simulation cycle, false otherwise.
S'last_event	The time interval since the last event on S .
S'last_value	The value of S just before the last event on S .

These attributes are often used in checking the timing behavior within a model. For example, we can verify that a signal **d** meets a minimum setup time requirement of **Tsu** before a rising edge on a clock **clk** of type **std_ulogic** as follows:

```

if clk'event and (clk = '1' or clk = 'H')
    and (clk'last_value = '0' or clk'last_value = 'L') then
        assert d'last_event >= Tsu
            report "Timing error: d changed within setup time of clk";
    end if;

```

EXAMPLE

We can test for the rising edge of a clock signal to model an edge-triggered flipflop. The flipflop loads the value of its **D** input on a rising edge of **clk**, but asynchronously clears the outputs whenever **clr** is '1'. The entity declaration and a behavioral architecture body are shown in Figure 4-2.

FIGURE 4-2

```

entity edge_triggered_Dff is
    port ( D : in bit; clk : in bit; clr : in bit;
          Q : out bit );
end entity edge_triggered_Dff;

-----

architecture behavioral of edge_triggered_Dff is
begin
    state_change : process (clk, clr) is
        begin
            if clr = '1' then
                Q <= '0' after 2 ns;
            elsif clk'event and clk = '1' then
                Q <= D after 2 ns;
            end if;
        end process state_change;

```

end architecture behavioral;

An entity and architecture body for an edge-triggered flipflop, using the 'event attribute to check for changes on the clk signal.

Wait Statements

Now that we have seen how to change the values of signals over time, the next step in behavioral modeling is to specify when processes respond to changes in signal values. This is done using *wait statements*. A wait statement is a sequential statement with the following syntax rule:

```
wait_statement ←
    wait [ on signal_name { , ... } ]
          [ until boolean_expression ]
          [ for time_expression ] ;
```

The purpose of the wait statement is to cause the process that executes the statement to suspend execution. The *sensitivity* clause, *condition* clause and *timeout* clause specify when the process is subsequently to resume execution. We can include any combination of these clauses, or we may omit all three. Let us go through each clause and describe what it specifies.

The sensitivity clause, starting with the word **on**, allows us to specify a list of signals to which the process responds. If we just include a sensitivity clause in a wait statement, the process will resume whenever any one of the listed signals changes value, that is, whenever an event occurs on any of the signals. This style of wait statement is useful in a process that models a block of combinatorial logic, since any change on the inputs may result in new output values; for example:

```
half_add : process is
begin
    sum <= a xor b after T_pd;
    carry <= a and b after T_pd;
    wait on a, b;
end process half_add;
```

This form of process is so common in modeling digital systems that VHDL provides the shorthand notation that we have seen in many examples in preceding chapters. A process with a sensitivity list in its heading is exactly equivalent to a process with a wait statement at the end, containing a sensitivity clause naming the signals in the sensitivity list. So the `half_add` process above could be rewritten as

```
half_add : process (a, b) is
begin
    sum <= a xor b after T_pd;
    carry <= a and b after T_pd;
end process half_add;
```

The condition clause in a wait statement, starting with the word **until**, allows us to specify a condition that must be true for the process to resume. For example, the wait statement

```
wait until clk = '1';
```

causes the executing process to suspend until the value of the signal `clk` changes to '1'. The condition expression is tested while the process is suspended to determine whether to resume the process. If the wait statement doesn't include a sensitivity clause, the condition is tested whenever an event occurs on any of the signals mentioned in the condition.

If a wait statement includes a sensitivity clause as well as a condition clause, the condition is only tested when an event occurs on any of the signals in the sensitivity clause. For example, if a process suspends on the following wait statement:

```
wait on clk until reset = '0';
```

the condition is tested on each change in the value of `clk`, regardless of any changes on `reset`.

The timeout clause in a wait statement, starting with the word **for**, allows us to specify a maximum interval of simulation time for which the process should be suspended. If we also include a sensitivity or condition clause, these may cause the process to be resumed earlier. For example, the wait statement

```
wait until trigger = '1' for 1 ms;
```

causes the executing process to suspend until `trigger` changes to '1', or until 1 ms of simulation time has elapsed, whichever comes first. If we just include a timeout clause by itself in a wait statement, the process will suspend for the time given.

If we refer back to the syntax rule for a wait statement shown on page 48, we note that it is legal to write

```
wait;
```

This form causes the executing process to suspend for the remainder of the simulation. We have seen an example of this in test-benches that suspend indefinitely after applying all of the stimuli.

Delta Delays

Let us now return to the topic of delays in signal assignments. In many of the example signal assignments in previous chapters, we omitted the delay part of waveform elements. This is equivalent to specifying a delay of 0 fs. The value is to be applied to the signal at the current simulation time. However, it is important to note that the signal value does not change as soon as the signal assignment statement is executed. Rather, the assignment schedules a transaction for the signal, which is applied after the process suspends. Thus the process does not see the effect of the assignment until the next time it resumes, even if this is at the same simulation time. For this reason, a delay of 0 fs in a signal assignment is called a *delta delay*.

To understand why delta delays work in this way, it is necessary to review the simulation cycle. Recall that the simulation cycle consists of two phases: a signal update phase followed by a process execution phase. In the signal update phase, simulation time is advanced to the time of the earliest scheduled transaction, and the values in all transactions scheduled for this time are applied to their corresponding signals. This may cause events to occur on some signals. In the process execution phase, all processes that respond to these events are resumed and execute until they suspend again on wait statements. The simulator then repeats the simulation cycle.

Let us now consider what happens when a process executes a signal assignment statement with delta delay, for example:

```
data <= X"00";
```

Suppose this is executed at simulation time t during the process execution phase of the current simulation cycle. The effect of the assignment is to schedule a transaction to put the value X"00" on **data** at time t . The transaction is not applied immediately, since the simulator is in the process execution phase. Hence the process continues executing, with **data** unchanged. When all processes have suspended, the simulator starts the next simulation cycle and updates the simulation time. Since the earliest transaction is now at time t , simulation time remains unchanged. The simulator now applies the value X"00" in the scheduled transaction to **data**, then resumes any processes that respond to the new value.

Process Statements

We have been using processes quite extensively in examples in this and previous chapters, so we have seen most of the details of how they are written and used. To summarize, let us now look at the formal syntax for a process statement and review process operation. The syntax rule is

```
process_statement ←
  process_label : process [ ( signal_name { , ... } ) ] [ is ]
    { process_declarative_item }
  begin
    { sequential_statement }
  end process [ process_label ] ;
```

The declarative items in a process statement may include constant, type and variable declarations, as well as other declarations that we will come to later. The sequential statements that form the process body may include any of those that we introduced earlier, plus signal assignment and wait statements. When a process is activated during simulation, it starts executing from the first sequential statement and continues until it reaches the last. It then starts again from the first. This would be an infinite loop, with no progress being made in the simulation, if it were not for the inclusion of wait statements, which suspend process execution until some relevant event occurs. Wait statements are the only statements that take more than zero simulation time to execute. It is only through the execution of wait statements that simulation time advances.

A process may include a sensitivity list in parentheses after the keyword **process**. The sensitivity list identifies a set of signals that the process monitors for events. If the sensitivity list is omitted, the process should include one or more wait statements. On the other hand, if the sensitivity list is included, then the process body cannot include any wait statements. Instead, there is an implicit wait statement, just before the **end process** keywords, that includes the signals listed in the sensitivity list as signals in an **on** clause.

Conditional Signal Assignment Statements

The conditional signal assignment statement is a concurrent statement that is a shorthand for a process containing a collection of ordinary signal assignments within an if statement. The syntax rule is

```
conditional_signal_assignment <=
    name <= { waveform when boolean_expression else }
            waveform [ when boolean_expression ] ;
```

The conditional signal assignment allows us to specify which of a number of waveforms should be assigned to a signal depending on the values of some conditions. For example, the following statement is a functional description of a multiplexer, with four data inputs (**d0**, **d1**, **d2** and **d3**), two select inputs (**sel0** and **sel1**) and a data output (**z**). All of these signals are of type **bit**.

```
z <=d0 when sel1 = '0' and sel0 = '0' else
    d1 when sel1 = '0' and sel0 = '1' else
    d2 when sel1 = '1' and sel0 = '0' else
    d3 when sel1 = '1' and sel0 = '1';
```

The statement is sensitive to all of the signals mentioned in the expressions and the conditions on the right of the assignment arrow. So whenever any of these change value, the conditional assignment is reevaluated and a new transaction scheduled on the driver for the target signal.

If we look more closely at the multiplexer model, we note that the last condition is redundant, since the signals **sel0** and **sel1** are of type **bit**. If none of the previous conditions are true, the signal should always be assigned the last waveform. So we can rewrite the example as:

```
z <=d0 when sel1 = '0' and sel0 = '0' else
    d1 when sel1 = '0' and sel0 = '1' else
    d2 when sel1 = '1' and sel0 = '0' else
    d3;
```

A very common case in function modeling is to write a conditional signal assignment with no conditions, as in the following example:

```
PC_incr : next_PC <= PC + 4 after 5 ns;
```

Selected Signal Assignment Statements

The selected signal assignment statement is similar in many ways to the conditional signal assignment statement. It is a shorthand for a process containing a number of ordinary signal assignments within a case statement. The syntax rule is

```
selected_signal_assignment <=
  with expression select
    name <= { waveform when choices , }
            waveform when choices ;
```

This statement allows us to choose between a number of waveforms to be assigned to a signal depending on the value of an expression. An example is:

```
with alu_function select
  result <=
    a + b after Tpd      when alu_add | alu_add_unsigned,
    a - b after Tpd      when alu_sub | alu_sub_unsigned,
    a and b after Tpd    when alu_and,
    a or b after Tpd     when alu_or,
    a after Tpd          when alu_pass_a;
```

A selected signal assignment statement is sensitive to all of the signals in the selector expression and in the expressions on the right of the assignment arrow. This means that the selected signal assignment above is sensitive to `alu_function`, `a` and `b`.

4.4 Structural Descriptions

A structural description of a system is expressed in terms of subsystems interconnected by signals. Each subsystem may in turn be composed of an interconnection of subsystems, and so on, until we finally reach a level consisting of primitive components, described purely in terms of their behavior. Thus the top-level system can be thought of as having a hierarchical structure. In this section, we look at how to write structural architecture bodies to express this hierarchical organization.

Entity Instantiation and Port Maps

We have seen earlier in this chapter that the concurrent statements in an architecture body describe an implementation of an entity interface. In order to write a structural implementation, we must use a concurrent statement called a *component instantiation* statement, the simplest form of which is governed by the syntax rule

```
component_instantiation_statement <=
  instantiation_label :
    entity entity_name ( architecture_identifier )
    port map ( port_association_list ) ;
```

This form of component instantiation statement performs *direct instantiation* of an entity. We can think of component instantiation as creating a copy of the named entity, with the corresponding architecture body substituted for the component in-

stance. The port map specifies which ports of the entity are connected to which signals in the enclosing architecture body. The simplified syntax rule for a port association list is

```
port_association_list ←
  ( [ port_name => ] signal_name ) { , ... }
```

Each element in the association list associates a port of the entity with a signal of the enclosing architecture body.

Let us look at some examples to illustrate component instantiation statements and the association of ports with signals. Suppose we have an entity declared as

```
entity DRAM_controller is
  port ( rd, wr, mem : in bit;
        ras, cas, we, ready : out bit );
end entity DRAM_controller;
```

and a corresponding architecture called `fpld`. We might create an instance of this entity as follows:

```
main_mem_controller : entity work.DRAM_controller(fpld)
  port map ( cpu_rd, cpu_wr, cpu_mem,
            mem_ras, mem_cas, mem_we, cpu_rdy );
```

In this example, the name `work` refers to the current working library in which entities and architecture bodies are stored. We return to the topic of libraries in the next section. The port map of this example lists the signals in the enclosing architecture body to which the ports of the copy of the entity are connected. *Positional association* is used: each signal listed in the port map is connected to the port at the same position in the entity declaration. So the signal `cpu_rd` is connected to the port `rd`, the signal `cpu_wr` is connected to the port `wr` and so on.

A better way of writing a component instantiation statement is to use *named association*, as shown in the following example:

```
main_mem_controller : entity work.DRAM_controller(fpld)
  port map ( rd => cpu_rd, wr => cpu_wr,
            mem => cpu_mem, ready => cpu_rdy,
            ras => mem_ras, cas => mem_cas, we => mem_we );
```

Here, each port is explicitly named along with the signal to which it is connected. The order in which the connections are listed is immaterial.

EXAMPLE

In Figure 4-2 we looked at a behavioral model of an edge-triggered flipflop. We can use the flipflop as the basis of a 4-bit edge-triggered register. Figure 4-3 shows the entity declaration and a structural architecture body.

FIGURE 4-3

```

entity reg4 is
  port ( clk, clr, d0, d1, d2, d3 : in bit; q0, q1, q2, q3 : out bit );
end entity reg4;

```

```

architecture struct of reg4 is
begin
  bit0 : entity work.edge_triggered_Dff(behavioral)
    port map (d0, clk, clr, q0);
  bit1 : entity work.edge_triggered_Dff(behavioral)
    port map (d1, clk, clr, q1);
  bit2 : entity work.edge_triggered_Dff(behavioral)
    port map (d2, clk, clr, q2);
  bit3 : entity work.edge_triggered_Dff(behavioral)
    port map (d3, clk, clr, q3);
end architecture struct;

```

An entity and structural architecture body for a 4-bit edge-triggered register, with an asynchronous clear input.

We can use the register entity, along with other entities, as part of a structural architecture for the two-digit decimal counter represented by the schematic of Figure 4-4.

Suppose a digit is represented as a bit vector of length four, described by the subtype declaration

```

subtype digit is bit_vector(3 downto 0);

```

Figure 4-5 shows the entity declaration for the counter, along with an outline of the structural architecture body. This example illustrates a number of important points about component instances and port maps. First, the two component instances `val0_reg` and `val1_reg` are both instances of the same entity/architecture pair. This means that two distinct copies of the architecture `struct` of `reg4` are created, one for each of the component instances. We return to this point when we discuss the topic of elaboration in the next section. Second, in each of the port maps, ports of the entity being instantiated are associated with separate elements of array signals. This is allowed, since a signal that is of a composite type, such as an array, can be treated as a collection of signals, one per element. Third, some of the signals connected to the component instances are signals declared within the enclosing architecture body, `registered`, whereas the `clk` signal is a port of the entity `counter`. This again illustrates the point that within an architecture body, the ports of the corresponding entity are treated as signals.

FIGURE 4-5

```

entity counter is
  port ( clk, clr : in bit;
        q0, q1 : out digit );
end entity counter;

```

FIGURE 4-4

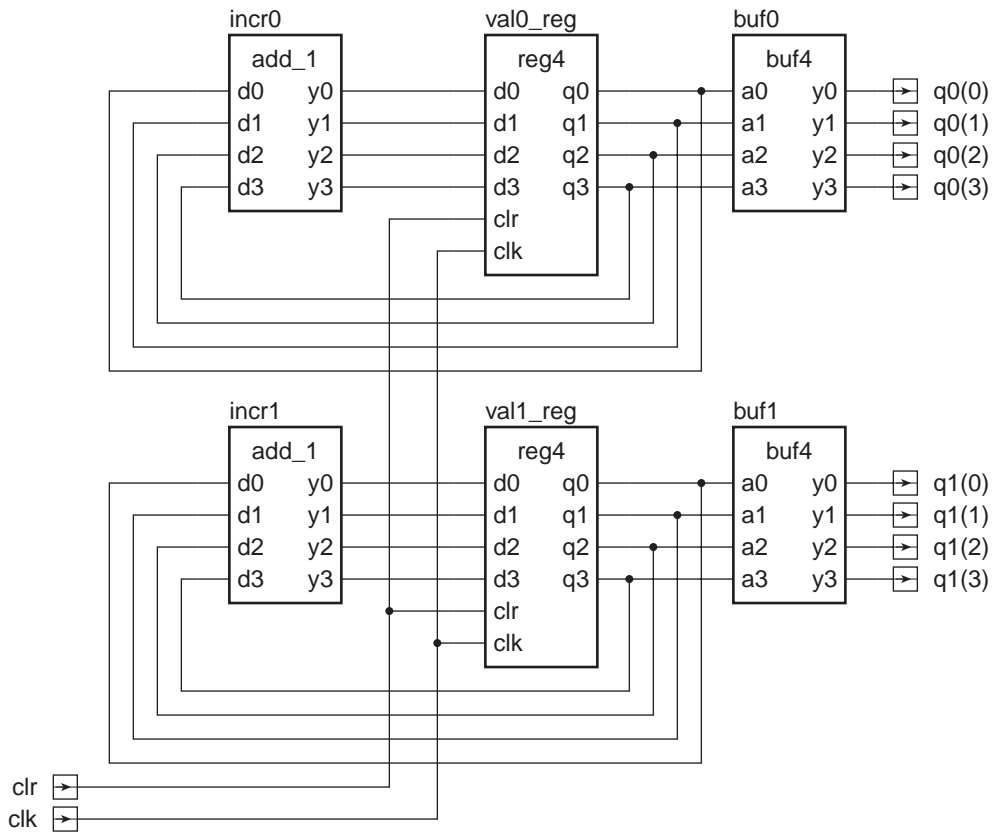

A schematic for a two-digit counter using the reg4 entity.

architecture registered of counter is

signal current_val0, current_val1, next_val0, next_val1 : digit;

begin

val0_reg : **entity** work.reg4(struct)

port map (d0 => next_val0(0), d1 => next_val0(1),
 d2 => next_val0(2), d3 => next_val0(3),
 q0 => current_val0(0), q1 => current_val0(1),
 q2 => current_val0(2), q3 => current_val0(3),
 clk => clk, clr => clr);

val1_reg : **entity** work.reg4(struct)

port map (d0 => next_val1(0), d1 => next_val1(1),
 d2 => next_val1(2), d3 => next_val1(3),
 q0 => current_val1(0), q1 => current_val1(1),
 q2 => current_val1(2), q3 => current_val1(3),
 clk => clk, clr => clr);

```

incr0 : entity work.add_1(boolean_eqn) ...;
incr1 : entity work.add_1(boolean_eqn) ...;
buf0  : entity work.buf4(basic) ...;
buf1  : entity work.buf4(basic) ...;
end architecture registered;

```

An entity declaration of a two-digit decimal counter, with an outline of an architecture body using the reg4 entity.

4.5 Libraries and Library Clauses

Earlier, we mentioned that a design is analyzed in order to check that it conforms to the syntax and semantic rules of VHDL. An analyzed design unit, such as an entity declaration or architecture body, is placed into a design library. A VHDL tool suite must provide some means of using a number of separate design libraries. When a design is analyzed, we nominate one of the libraries as the *working library*, and the analyzed design is stored in this library. We use the special library name **work** in our VHDL models to refer to the current working library. We have seen examples of this in this chapter's component instantiation statements, in which a previously analyzed entity is instantiated in a structural architecture body.

If we need to access library units stored in other libraries, we refer to the libraries as *resource libraries*. We do this by including a *library clause* immediately preceding a design unit that accesses the resource libraries. The syntax rule for a library clause is

$$\text{library_clause} \leftarrow \mathbf{library} \text{ identifier } \{ , \dots \} ;$$

The identifiers are used by the analyzer and the host operating system to locate the design libraries, so that the units contained in them can be used in the description being analyzed. The exact way that the identifiers are used varies between different tool suites and is not defined by the VHDL language specification. Note that we do not need to include the library name **work** in a library clause; the current working library is automatically available.

EXAMPLE

Suppose we are working on part of a large design project code-named Wasp, and we are using standard cell parts supplied by Widget Designs, Inc. Our system administrator has loaded the design library for the Widget cells in a directory called `/local/widget/cells` in our workstation file system, and our project leader has set up another design library in `/projects/wasp/lib` for some in-house cells we need to use. We consult the manual for our VHDL analyzer and use operating system commands to set up the appropriate mapping from the identifiers `widget_cells` and `wasp_lib` to these library directories. We can then instantiate entities from these libraries, along with entities we have previously analyzed, into our own working library, as shown in Figure 4-6.

FIGURE 4-6

```
library widget_cells, wasp_lib;
architecture cell_based of filter is
    -- declaration of signals, etc
    ...
begin
    clk_pad : entity wasp_lib.in_pad
        port map ( i => clk, z => filter_clk );
    accum : entity widget_cells.reg32
        port map ( en => accum_en, clk => filter_clk, d => sum,
            q => result );
    alu : entity work.adder
        port map ( a => alu_op1, b => alu_op2, y => sum, c => carry );
    -- other component instantiations
    ...
end architecture cell_based;
```

An outline of a library unit referring to entities from the resource libraries widget_cells and wasp_lib.

5

Subprograms

5.1 Procedures

We start our discussion of subprograms with procedures. There are two aspects to using procedures in a model: first the procedure is declared, then elsewhere the procedure is *called*. The syntax rule for a procedure declaration is

```
subprogram_body  $\leftarrow$   
  procedure identifier [ ( parameter_interface_list ) ] is  
    { subprogram_declarative_part }  
  begin  
    { sequential_statement }  
  end [ procedure ] [ identifier ] ;
```

For now we will just look at procedures without the parameter list part; we will come back to parameters in the next section.

The *identifier* in a procedure declaration names the procedure. The name may be repeated at the end of the procedure declaration. The sequential statements in the body of a procedure implement the algorithm that the procedure is to perform and can include any of the sequential statements that we have seen in previous chapters. A procedure can declare items in its declarative part for use in the statements in the procedure body. The declarations can include types, subtypes, constants, variables and nested subprogram declarations. The items declared are not accessible outside of the procedure; we say they are *local* to the procedure.

The actions of a procedure are invoked by a *procedure call* statement, which is yet another VHDL sequential statement. A procedure with no parameters is called simply by writing its name, as shown by the syntax rule

```
procedure_call_statement  $\leftarrow$  procedure_name ;
```

When the last statement in the procedure is completed, the procedure *returns*.

We can write a procedure declaration in the declarative part of an architecture body or a process. If a procedure is included in an architecture body's declarative part, it can be called from within any of the processes in the architecture body. On the other hand, declaring a procedure within a process hides it away from use by other processes.

EXAMPLE

The outline in Figure 5-1 illustrates a procedure for arithmetic operations defined within a process. The process `alu` invokes `do_arith_op` with a procedure call statement.

FIGURE 5-1

```

architecture rtl of control_processor is
  type func_code is (add, subtract);
  signal op1, op2, dest : integer;
  signal Z_flag : boolean;
  signal func : func_code;
  ...
begin
  alu : process is
    procedure do_arith_op is
      variable result : integer;
    begin
      case func is
        when add =>
          result := op1 + op2;
        when subtract =>
          result := op1 - op2;
      end case;
      dest <= result after Tpd;
      Z_flag <= result = 0 after Tpd;
    end procedure do_arith_op;
  begin
    ...
    do_arith_op;
    ...
  end process alu;
  ...
end architecture rtl;

```

An outline of an architecture body with a process containing a procedure. The procedure encapsulates part of the behavior of the process and is invoked by the procedure call statement within the process.

5.2 Procedure Parameters

Now that we have looked at the basics of procedures, we will discuss procedures that include parameters. When we write a parameterized procedure, we include information in the *parameter list* about the parameters to be passed to the procedure. The syntax rule for a procedure declaration on page 59 shows where the parameter list fits in. Following is the syntax rule for a parameter list:

```

interface_list <=
  ( [ constant | variable | signal ]
    identifier { , ... } : [ mode ] subtype_indication
                                     [ := static_expression ] ) { ; ... }

mode <= in | out | inout

```

The parameter list defines the *formal parameters* of the procedure. We can think of them as placeholders that stand for the *actual parameters*, which are to be supplied by the caller when it calls the procedure. Since the syntax rule for a parameter list is quite complex, let us start with some simple examples and work up from them.

EXAMPLE

First, let's rewrite the procedure `do_arith_op`, from Figure 5-1, so that the function code is passed as a parameter. The new version is shown in Figure 5-2. In the parameter interface list we have identified one formal parameter named `op`. The mode of the formal parameter is **in**, indicating that it is used to pass information into the procedure from the caller. The type of the parameter is `func_code`, indicating that the operations performed on the formal parameter must be appropriate for a value of this type and that the caller may only pass a value of this type as an actual parameter.

Now that we have parameterized the procedure, we can call it from different places passing different function codes each time. For example, a call at one place might be

```
do_arith_op ( add );
```

The procedure call simply includes the actual parameter value in parentheses. In this case we pass the literal value `add` as the actual parameter. At another place in the model we might pass the value of the signal `func` shown in the model in Figure 5-1:

```
do_arith_op ( func );
```

FIGURE 5-2

```

procedure do_arith_op ( op : in func_code ) is
  variable result : integer;
begin
  case op is
    when add =>
      result := op1 + op2;
    when subtract =>
      result := op1 - op2;
  end case;
  dest <= result after Tpd;
  Z_flag <= result = 0 after Tpd;
end procedure do_arith_op;

```

A procedure to perform an arithmetic operation, parameterized by the kind of operation.

The syntax rule for a parameter list also shows us that we can specify the *class* of a formal parameter, namely, whether it is a constant, a variable or a signal within the procedure. If the mode of the parameter is **in**, the class is assumed to be *constant*, since a constant is an object that cannot be updated by assignment. Usually we simply leave out the keyword **constant**, relying on the mode to make our intentions clear. For an **in** mode constant-class parameter, we write an expression as the actual parameter.

Let us now turn to formal parameters of mode **out**. Such a parameter lets us transfer information out from the procedure back to the caller. Here is an example.

EXAMPLE

The procedure in Figure 5-3 performs addition of two unsigned numbers represented as bit vectors of type **word32**, which we assume is defined elsewhere. The procedure has two **in** mode parameters **a** and **b**, allowing the caller to pass two bit-vector values. The procedure uses these values to calculate the sum and overflow flag. Within the procedure, the two **out** mode parameters, **result** and **overflow**, appear as variables. The procedure performs variable assignments to update their values, thus transferring information back to the caller.

FIGURE 5-3

```

procedure addu ( a, b : in word32;
                result : out word32; overflow : out boolean ) is
  variable sum : word32;
  variable carry : bit := '0';
begin
  for index in sum'reverse_range loop
    sum(index) := a(index) xor b(index) xor carry;
    carry := ( a(index) and b(index) ) or ( carry and ( a(index) xor b(index) ) );
  end loop;
  result := sum;

```

```

    overflow := carry = '1';
end procedure addu;

```

A procedure to add two bit vectors representing unsigned integers.

A call to this procedure may appear as follows:

```

variable PC, next_PC : word32;
variable overflow_flag : boolean;
...
addu ( PC, X"0000_0004", next_PC, overflow_flag);

```

In the above example, the **out** mode parameters are of the class *variable*. Since this class is assumed for **out** parameters, we usually leave out the class specification **variable**. The mode **out** indicates that the only way the procedure may use the formal parameters is to update them by variable assignment; it may not read the values of the parameters. For an **out** mode, variable-class parameter, the caller must supply a variable as an actual parameter.

The third mode we can specify for formal parameters is **inout**, which is a combination of **in** and **out** modes. It is used for objects that are to be both read and updated by a procedure. As with **out** parameters, they are assumed to be of class *variable* if the class is not explicitly stated. For **inout** mode variable parameters, the caller supplies a variable as an actual parameter. The value of this variable is used to initialize the formal parameter, which may then be used in the statements of the procedure. The procedure may also perform variable assignments to update the formal parameter. When the procedure returns, the value of the formal parameter is copied back to the actual parameter variable, transferring information back to the caller.

Signal Parameters

The third class of object that we can specify for formal parameters is *signal*, which indicates that the algorithm performed by the procedure involves a signal passed by the caller. A signal parameter can be of any of the modes **in**, **out** or **inout**.

The way that signal parameters work is somewhat different from constant and variable parameters. When a caller passes a signal as a parameter of mode **in**, instead of passing the value of the signal, it passes the signal object itself. Any reference to the formal parameter within the procedure is exactly like a reference to the actual signal itself.

EXAMPLE

Suppose we wish to model the receiver part of a network interface. It receives fixed-length packets of data on the signal **rx_data**. The data is synchronized with changes, from '0' to '1', of the clock signal **rx_clock**. Figure 5-4 is an outline of part of the model.

FIGURE 5-4

```

architecture behavioral of receiver is
  ... -- type declarations, etc
  signal recovered_data : bit;
  signal recovered_clock : bit;
  ...
  procedure receive_packet ( signal rx_data : in bit;
                           signal rx_clock : in bit;
                           data_buffer : out packet_array ) is

    begin
      for index in packet_index_range loop
        wait until rx_clock = '1';
        data_buffer(index) := rx_data;
      end loop;
    end procedure receive_packet;
begin
  packet_assembler : process is
    variable packet : packet_array;
  begin
    ...
    receive_packet ( recovered_data, recovered_clock, packet );
    ...
  end process packet_assembler;
  ...
end architecture behavioral;

```

*An outline of a model of a network receiver, including a procedure with signal parameters of mode **in**.*

During execution of the model, the process `packet_assembler` calls the procedure `receive_packet`, passing the signals `recovered_data` and `recovered_clock` as actual parameters. The wait statement mentions `rx_clock`, and since this stands for `recovered_clock`, the process is sensitive to changes on `recovered_clock` while it is suspended.

Now let's look at signal parameters of mode **out**. In this case, the caller must name a signal as the actual parameter, and the procedure is passed a reference to the driver for the signal. When the procedure performs a signal assignment statement on the formal parameter, the transactions are scheduled on the driver for the actual signal parameter.

EXAMPLE

Figure 5-5 is an outline of an architecture body for a signal generator. The procedure `generate_pulse_train` has **in** mode constant parameters that specify the characteristics of a pulse train and an **out** mode signal parameter on which it generates the required pulse train. The process `raw_signal_generator` calls the proce-

cedure, supplying `raw_signal` as the actual signal parameter for `s`. A reference to the driver for `raw_signal` is passed to the procedure, and transactions are generated on it.

FIGURE 5-5

```

library ieee; use ieee.std_logic_1164.all;
architecture top_level of signal_generator is
    signal raw_signal : std_ulogic;
    ...
    procedure generate_pulse_train ( width, separation : in delay_length;
                                    number : in natural;
                                    signal s : out std_ulogic ) is

        begin
            for count in 1 to number loop
                s <= '1', '0' after width;
                wait for width + separation;
            end loop;
        end procedure generate_pulse_train;
begin
    raw_signal_generator : process is
        begin
            ...
            generate_pulse_train ( width => period / 2,
                                  separation => period - period / 2,
                                  number => pulse_count,
                                  s => raw_signal );
            ...
        end process raw_signal_generator;
        ...
end architecture top_level;

```

*An outline of a model for a signal generator, including a pulse generator procedure with an **out** mode signal parameter.*

As with variable-class parameters, we can also have a signal-class parameter of mode **inout**. When the procedure is called, both the signal and a reference to its driver are passed to the procedure. The statements within it can read the signal value, include it in sensitivity lists in wait statements, query its attributes and schedule transactions using signal assignment statements.

Default Values

The one remaining part of a procedure parameter list that we have yet to discuss is the optional default value expression, shown in the syntax rule on page 61. Note that we can only specify a default value for a formal parameter of mode **in**, and the parameter must be of the class constant or variable. If we include a default value in a

parameter specification, we have the option of omitting an actual value when the procedure is called. We can either use the keyword **open** in place of an actual parameter value or, if the actual value would be at the end of the parameter list, simply leave it out. If we omit an actual value, the default value is used instead.

Unconstrained Array Parameters

In an earlier chapter we described unconstrained array types, in which the index range of the array was left unspecified using the “box” (“<>”) notation. For such a type, we constrain the index bounds when we create an object, such as a variable or a signal. Another use of an unconstrained array type is as the type of a formal parameter to procedure. This use allows us to write a procedure in a general way, so that it can operate on array values of any size or with any range of index values. When we call the procedure and provide a constrained array as the actual parameter, the index bounds of the actual array are used as the bounds of the formal array parameter.

EXAMPLE

Figure 5-6 is a procedure that finds the index of the first bit set to ‘1’ in a bit vector. The formal parameter *v* is of type **bit_vector**, which is an unconstrained array type. Note that in writing this procedure, we do not explicitly refer to the index bounds of the formal parameter *v*, since they are not known. Instead, we use the *'range* attribute.

FIGURE 5-6

```

procedure find_first_set ( v : in bit_vector;
                          found : out boolean;
                          first_set_index : out natural ) is

begin
    for index in v'range loop
        if v(index) = '1' then
            found := true;
            first_set_index := index;
            return;
        end if;
    end loop;
    found := false;
end procedure find_first_set;

```

A procedure to find the first set bit in a bit vector.

When the procedure is executed, the formal parameters stand for the actual parameters provided by the caller. So if we call this procedure as follows:

```

variable int_req : bit_vector (7 downto 0);
variable top_priority : natural;
variable int_pending : boolean;
...
find_first_set ( int_req, int_pending, top_priority );

```

`v'range` returns the range **7 downto 0**, which is used to ensure that the loop parameter `index` iterates over the correct index values for `v`. If we make a different call:

```

variable free_block_map : bit_vector(0 to block_count-1);
variable first_free_block : natural;
variable free_block_found : boolean;
...
find_first_set ( free_block_map, free_block_found, first_free_block );

```

`v'range` returns the index range of the array `free_block_map`, since that is the actual parameter corresponding to `v`.

5.3 Functions

Let us now turn our attention to the second kind of subprogram in VHDL: *functions*. The syntax rule for a function declaration is very similar to that for a procedure declaration:

```

subprogram_body ←
    function identifier [ ( parameter_interface_list ) ] return type_mark is
        { subprogram_declarative_item }
    begin
        { sequential_statement }
    end [ function ] [ identifier ] ;

```

The identifier in the declaration names the function. It may be repeated at the end of the declaration. Unlike a procedure subprogram, a function calculates and returns a result that can be used in an expression. The function declaration specifies the type of the result after the keyword **return**. The parameter list of a function takes the same form as that for a procedure, with two restrictions. First, the parameters of a function may not be of the class variable. If the class is not explicitly mentioned, it is assumed to be constant. Second, the mode of each parameter must be **in**. If the mode is not explicitly specified, it is assumed to be **in**. Like a procedure, a function can declare local items in its declarative part for use in the statements in the function body.

A function passes the result of its computation back to its caller using a return statement, given by the syntax rule

```

return_statement ← return expression ;

```

A function must include at least one return statement. The first to be executed causes the function to complete and return its result to the caller. A function cannot simply run into the end of the function body, since to do so would not provide a way of specifying a result to pass back to the caller.

A function call looks exactly like a procedure call. The syntax rule is

```

function_call ← function_name [ ( parameter_association_list ) ]

```

The difference is that a function call is part of an expression, rather than being a sequential statement on its own, like a procedure call.

EXAMPLE

The function in Figure 5-7 determines the number represented in binary by a bit-vector value.

FIGURE 5-7

```
function bv_to_natural ( bv : in bit_vector ) return natural is
  variable result : natural := 0;
begin
  for index in bv'range loop
    result := result * 2 + bit'pos(bv(index));
  end loop;
  return result;
end function bv_to_natural;
```

A function that converts the binary representation of an unsigned number to a numeric value.

As an example of using this function, consider a model for a read-only memory, which represents the stored data as an array of bit vectors, as follows:

```
type rom_array is array (natural range 0 to rom_size-1)
  of bit_vector(0 to word_size-1);
variable rom_data : rom_array;
```

If the model has an address port that is a bit vector, we can use the function to convert the address to a natural value to index the ROM data array, as follows:

```
data <= rom_data ( bv_to_natural(address) ) after Taccess;
```

6

Packages and Use Clauses

6.1 Package Declarations and Bodies

A VHDL package is simply a way of grouping a collection of related declarations that serve a common purpose. They allow us to separate the external view of the items they declare from the implementation of those items. The external view is specified in a *package declaration*, whereas the implementation is defined in a separate *package body*. The syntax rule for writing a package declaration is

```
package_declaration ←  
    package identifier is  
        { package_declarative_item }  
    end [ package ] [ identifier ] ;
```

The identifier provides a name for the package, which we can use elsewhere in a model to refer to the package. Inside the package declaration we write a collection of declarations, including type, subtype, constant, signal and subprogram declarations. These are the declarations that are provided to the users of the package. Figure 6-1 is a simple example of a package declaration.

FIGURE 6-1

```
package cpu_types is  
    constant word_size : positive := 16;  
    constant address_size : positive := 24;  
    subtype word is bit_vector(word_size - 1 downto 0);  
    subtype address is bit_vector(address_size - 1 downto 0);  
    type status_value is ( halted, idle, fetch, mem_read, mem_write,  
                          io_read, io_write, int_ack );  
end package cpu_types;
```

A package that declares some useful constants and types for a CPU model.

A package is another form of design unit, along with entity declarations and architecture bodies. It is separately analyzed and is placed into the working library as a library unit by the analyzer. From there, other library units can refer to an item declared in the package using the *selected name* of the item. The selected name is

formed by writing the library name, then the package name and then the name of the item, all separated by dots; for example:

```
work.cpu_types.status_value
```

Subprograms in Package Declarations

Another kind of declaration that may be included in a package declaration is a subprogram declaration—either a procedure or a function declaration. An important aspect of declaring a subprogram in a package declaration is that we only write the header of the subprogram, that is, the part that includes the name and the interface list defining the parameters (and result type for functions). We leave out the body of the subprogram. For example, suppose we have a package declaration that defines a bit-vector subtype:

```
subtype word32 is bit_vector(31 downto 0);
```

We can include in the package a procedure to do addition on `word32` values that represent signed integers. The procedure declaration in the package declaration is

```
procedure add ( a, b : in word32;  
               result : out word32; overflow : out boolean );
```

Note that we do not include the keyword `is` or any of the local declarations or statements needed to perform the addition; these are deferred to the package body. Each package declaration that includes subprogram declarations must have a corresponding package body to fill in the missing details. However, if a package declaration only includes other kinds of declarations, such as types, signals or fully specified constants, no package body is necessary. The syntax rule for a package body is similar to that for the interface, but with the inclusion of the keyword `body`:

```
package_body <=
  package body identifier is
    { package_body_declarative_item }
  end [ package body ] [ identifier ] ;
```

The items declared in a package body must include the full declarations of all subprograms defined in the corresponding package declaration. These full declarations must include the subprogram headers exactly as they are written in the package declaration. A package body may also include declarations of additional types, subtypes, constants and subprograms. These items are used to implement the subprograms defined in the package declaration. Note that the items declared in the package declaration cannot be declared again in the body (apart from subprograms and deferred constants, as described above), since they are automatically visible in the body.

EXAMPLE

Figure 6-2 shows outlines of a package declaration and a package body declaring arithmetic functions for bit-vector values. The functions treat bit vectors

as representing signed integers in binary form. Only the function headers are included in the package declaration. The package body contains the full function bodies. It also includes a function, `mult_unsigned`, not defined in the package declaration. It is used internally in the package body to implement the signed multiplication operator.

FIGURE 6-2

```

package bit_vector_signed_arithmetic is
    function add ( bv1, bv2 : bit_vector ) return bit_vector;
    function sub ( bv : bit_vector ) return bit_vector;
    function mult ( bv1, bv2 : bit_vector ) return bit_vector;
    ...
end package bit_vector_signed_arithmetic;
-----
package body bit_vector_signed_arithmetic is
    function add ( bv1, bv2 : bit_vector ) return bit_vector is ...
    function sub ( bv : bit_vector ) return bit_vector is ...
    function mult_unsigned ( bv1, bv2 : bit_vector ) return bit_vector is
        ...
    begin
        ...
    end function mult_unsigned;
    function mult ( bv1, bv2 : bit_vector ) return bit_vector is
    begin
        if bv1(bv1'left) = '0' and bv2(bv2'left) = '0' then
            return mult_unsigned(bv1, bv2);
        elsif bv1(bv1'left) = '0' and bv2(bv2'left) = '1' then
            return -mult_unsigned(bv1, -bv2);
        elsif bv1(bv1'left) = '1' and bv2(bv2'left) = '0' then
            return -mult_unsigned(-bv1, bv2);
        else
            return mult_unsigned(-bv1, -bv2);
        end if;
    end function mult;
    ...
end package body bit_vector_signed_arithmetic;

```

An outline of a package declaration and body that define signed arithmetic functions on integers represented as bit vectors.

6.2 Use Clauses

We have seen how we can refer to an item provided by a package by writing its selected name, for example, `work.cpu_types.status_value`. This name refers to the item `status_value` in the package `cpu_types` stored in the library `work`. If we need to refer

to this object in many places in a model, having to write the library name and package name becomes tedious and can obscure the intent of the model. We can write a *use clause* to make names from package directly visible. The syntax rules are:

```
use_clause  $\Leftarrow$  use selected_name { , ... } ;
selected_name  $\Leftarrow$  identifier . identifier . ( identifier | all )
```

In one form of selected name, the first identifier is a library name and the second is the name of a package within the library. This form allows us to refer directly to items within a package without having to use the full selected name. For example, we could write a use clause

```
use work.cpu_types.word, work.cpu_types.address;
```

and then refer to the used names in declarations:

```
variable data_word : word;
variable next_address : address;
```

We can place a use clause in any declarative part in a model. One way to think of a use clause is that it “imports” the names of the listed items into the part of the model containing the use clause.

The syntax rule for a use clause shows that we can write the keyword **all** instead of the name of a particular item to import from a package. This form is very useful, as it is a shorthand way of importing all of the names defined in the interface of a package. For example, if we are using the IEEE standard-logic package as the basis for the data types in a design, we can import everything from the standard-logic package with a use clause as follows:

```
use ieee.std_logic_1164.all;
```

Use clauses may be included at the beginning of a design unit, as well as in declarative parts within a design unit. We have seen earlier how we may include library and use clauses at the head of a design unit, such as an entity interface or architecture body. This area of a design unit is called its *context clause*. The names imported here are made directly visible throughout the design unit. For example, if we want to use the IEEE standard-logic types in the declaration of an entity, we might write the design unit as follows:

```
library ieee; use ieee.std_logic_1164.all;
entity logic_block is
  port ( a, b : in std_ulogic;
        y, z : out std_ulogic );
end entity logic_block;
```

The names imported by a use clause in this way are made directly visible in the entire design unit after the use clause. In addition, if the design unit is a primary unit (such as an entity declaration or a package declaration), the visibility is extended to any corresponding secondary unit. Thus, if we include a use clause in the primary

unit, we do not need to repeat it in the secondary unit, as the names are automatically visible there.

7

Resolved Signals

7.1 IEEE Std_Logic_1164 Resolved Subtypes

VHDL provides a very general mechanism for specifying what value results from connecting multiple outputs together. It does this through *resolved subtypes* and *resolved signals*, which are an extension of the basic signals we have used in previous chapters. However, most designs simply use the resolved subtypes defined in the standard-logic package, `std_logic_1164`. In this tutorial, we will restrict our attention to those subtypes.

First, recall that the package provides the basic type `std_ulogic`, defined as

```
type std_ulogic is ('U', 'X', '0', '1', 'Z', 'W', 'L', 'H', '-');
```

and an array type `std_ulogic_vector`, defined as

```
type std_ulogic_vector is array ( natural range <> ) of std_ulogic;
```

We have not mentioned it before, but the “u” in “ulogic” stands for unresolved. Signals of these types cannot have multiple sources. The standard-logic package also provides a resolved subtype called `std_logic`. A signals of this type can have multiple sources. The package also declares an array type of standard-logic elements, analogous to the `bit_vector` type, for use in declaring array signals:

```
type std_logic_vector is array ( natural range <> ) of std_logic;
```

The standard defines the way in which contributions from multiple sources are resolved to yield the final value for a signal. If there is only one driving value, that value is used. If one driver of a resolved signal drives a forcing value ('X', '0' or '1') and another drives a weak value ('W', 'L' or 'H'), the forcing value dominates. On the other hand, if both drivers drive different values with the same strength, the result is the unknown value of that strength ('X' or 'W'). The high-impedance value, 'Z', is dominated by forcing and weak values. If a “don't care” value ('-') is resolved with any other value, the result is the unknown value 'X'. The interpretation of the “don't care” value is that the model has not made a choice about its output state. Finally, if an “uninitialized” value ('U') is to be resolved with any other value, the result is 'U', indicating that the model has not properly initialized all outputs.

In addition to this multivalued logic subtype, the package `std_logic_1164` declares a number of subtypes for more restricted multivalued logic modeling. The subtype declarations are

```

subtype X01 is resolved std_ulogic range 'X' to '1';      -- ('X','0','1')
subtype X01Z is resolved std_ulogic range 'X' to 'Z';     -- ('X','0','1','Z')
subtype UX01 is resolved std_ulogic range 'U' to '1';    -- ('U','X','0','1')
subtype UX01Z is resolved std_ulogic range 'U' to 'Z';  -- ('U','X','0','1','Z')

```

The standard-logic package provides the logical operators **and**, **nand**, **or**, **nor**, **xor**, **xnor** and **not** for standard-logic values and vectors, returning values in the range 'U', 'X', '0' or '1'. In addition, there are functions to convert between values of the full standard-logic type, the subtypes shown above and the predefined bit and bit-vector types.

7.2 Resolved Signals and Ports

In the previous discussion of resolved signals, we have limited ourselves to the simple case where a number of sources drive a signal. Any input port connected to the resolved signal gets the final resolved value as the port value. We now look in more detail at the case of a port of mode **inout** being connected to a resolved signal. The value seen by the input side of such a port is the final value of the resolved signal connected to the port. An **inout** port models a connection in which the driver contributes to the associated signal's value, and the input side of the component senses the actual signal rather than using the driving value.

EXAMPLE

Some asynchronous bus protocols use a distributed synchronization mechanism based on a wired-and control signal. This is a single signal driven by each module using active-low open-collector or open-drain drivers and pulled up by the bus terminator. If a number of modules on the bus need to wait until all are ready to proceed with some operation, they use the control signal as follows. Initially, all modules drive the signal to the '0' state. When each is ready to proceed, it turns off its driver ('Z') and monitors the control signal. So long as any module is not yet ready, the signal remains at '0'. When all modules are ready, the bus terminator pulls the signal up to the '1' state. All modules sense this change and proceed with the operation.

Figure 7-1 shows an entity declaration for a bus module that has a port of the unresolved type `std_ulogic` for connection to such a synchronization control signal. The architecture body for a system comprising several such modules is also outlined. The control signal is pulled up by a concurrent signal assignment statement, which acts as a source with a constant driving value of 'H'. This is a value having a weak strength, which is overridden by any other source that drives '0'. It can pull the signal high only when all other sources drive 'Z'.

FIGURE 7-1

```

library ieee; use ieee.std_logic_1164.all;
entity bus_module is
    port ( synch : inout std_ulogic; ... );
end entity bus_module;

-----

architecture top_level of bus_based_system is
    signal synch_control : std_logic;
    ...
begin
    synch_control_pull_up : synch_control <= 'H';
    bus_module_1 : entity work.bus_module(behavioral)
        port map ( synch => synch_control, ... );
    bus_module_2 : entity work.bus_module(behavioral)
        port map ( synch => synch_control, ... );
    ...
end architecture top_level;

```

An entity declaration for a bus module that uses a wired-and synchronization signal, and an architecture body that instantiates the entity, connecting the synchronization port to a resolved signal.

Figure 7-2 shows an outline of a behavioral architecture body for the bus module. Each instance initially drives its synchronization port with '0'. This value is passed up through the port and used as the contribution to the resolved signal from the entity instance. When an instance is ready to proceed with its operation, it changes its driving value to 'Z', modeling an open-collector or open-drain driver being turned off. The process then suspends until the value seen on the synchronization port changes to 'H'. If other instances are still driving '0', their contributions dominate, and the value of the signal stays '0'. When all other instances eventually change their contributions to 'Z', the value 'H' contributed by the pull-up statement dominates, and the value of the signal changes to 'H'. This value is passed back down through the ports of each instance, and the processes all resume.

FIGURE 7-2

```

architecture behavioral of bus_module is
begin
    behavior : process is
        ...
    begin
        synch <= '0' after Tdelay_synch;
        ...
        -- ready to start operation
        synch <= 'Z' after Tdelay_synch;
        wait until synch = 'H';
        -- proceed with operation

```

```
...  
end process behavior;  
end architecture behavioral;
```

An outline of a behavioral architecture body for a bus module, showing use of the synchronization control port.

8

Generic Constants

8.1 Parameterizing Behavior

VHDL provides us with a mechanism, called *generics*, for writing parameterized models. We can write a generic entity by including a *generic list* in its declaration that defines the *formal generic constants* that parameterize the entity. The extended syntax rule for entity declarations including generics is

```
entity_declaration ←
    entity identifier is
        [ generic ( generic_interface_list ) ; ]
        [ port ( port_interface_list ) ; ]
    end [ entity ] [ identifier ] ;
```

The generic interface list is like a parameter list, but with the restriction that we can only include constant-class objects, which must be of mode **in**. Since these are the defaults for a generic list, we can use a simplified syntax rule:

```
generic_interface_list ←
    ( identifier { , ... } : subtype_indication [ := expression ] )
    { ; ... }
```

A simple example of an entity declaration including a generic interface list is

```
entity and2 is
    generic ( Tpd : time );
    port ( a, b : in bit; y : out bit );
end entity and2;
```

This entity includes one generic constant, **Tpd**, of the predefined type **time**. The value of this generic constant may be used within the entity statements and any architecture body corresponding to the entity. In this example the intention is that the generic constant specify the propagation delay for the module, so the value should be used in a signal assignment statement as the delay. An architecture body that does this is

```
architecture simple of and2 is
begin
```

```

and2_function :
    y <= a and b after Tpd;
end architecture simple;

```

A generic constant is given an actual value when the entity is used in a component instantiation statement. We do this by including a *generic map*, as shown by the extended syntax rule for component instantiations:

```

component_instantiation_statement <=
    instantiation_label :
        entity entity_name ( architecture_identifier )
        [ generic map ( generic_association_list ) ]
        port map ( port_association_list );

```

The generic association list is like other forms of association lists, but since generic constants are always of class constant, the actual arguments we supply must be expressions. Thus the simplified syntax rule for a generic association list is

```

generic_association_list <=
    ( [ generic_name => ] ( expression | open ) ) { , ... }

```

To illustrate this, let us look at a component instantiation statement that uses the `and2` entity shown above:

```

gate1 : entity work.and2(simple)
    generic map ( Tpd => 2 ns )
    port map ( a => sig1, b => sig2, y => sig_out );

```

The generic map specifies that this instance of the `and2` module uses the value 2 ns for the generic constant `Tpd`; that is, the instance has a propagation delay of 2 ns. We might include another component instantiation statement using `and2` in the same design but with a different actual value for `Tpd` in its generic map, for example:

```

gate2 : entity work.and2(simple)
    generic map ( Tpd => 3 ns )
    port map ( a => a1, b => b1, y => sig1 );

```

When the design is elaborated we have two processes, one corresponding to the instance `gate1` of `and2`, which uses the value 2 ns for `Tpd`, and another corresponding to the instance `gate2` of `and2`, which uses the value 3 ns.

8.2 Parameterizing Structure

The second main use of generic constants in entities is to parameterize their structure. We can use the value of a generic constant to specify the size of an array port by using the generic constant in constraints in the port declarations. To illustrate, here is an entity declaration for a register:

```

entity reg is
    generic ( width : positive );

```

```

    port ( d : in bit_vector(0 to width - 1);
          q : out bit_vector(0 to width - 1);
          ... );
end entity reg;

```

In this declaration we require that the user of the register specify the desired port width for each instance. The entity then uses the width value as a constraint on both the input and output ports. A component instantiation using this entity might appear as follows:

```

signal in_data, out_data : bit_vector(0 to bus_size - 1);
...
ok_reg : entity work.reg
    generic map ( width => bus_size )
    port map ( d => in_data, q => out_data, ... );

```

EXAMPLE

A complete model for the register, including the entity declaration and an architecture body, is shown in Figure 8-1. The generic constant is used to constrain the widths of the data input and output ports in the entity declaration. It is also used in the architecture body to determine the size of the constant bit vector `zero`. This bit vector is the value assigned to the register output when it is reset, so it must be of the same size as the register port.

We can create instances of the register entity in a design, each possibly having different-sized ports. For example:

```

word_reg : entity work.reg(behavioral)
    generic map ( width => 32 )
    port map ( ... );

```

creates an instance with 32-bit-wide ports. In the same design, we might include another instance, as follows:

```

subtype state_vector is bit_vector(1 to 5);
...
state_reg : entity work.reg(behavioral)
    generic map ( width => state_vector'length )
    port map ( ... );

```

This register instance has 5-bit-wide ports, wide enough to store values of the subtype `state_vector`.

FIGURE 8-1

```

entity reg is
    generic ( width : positive );
    port ( d : in bit_vector(0 to width - 1);
          q : out bit_vector(0 to width - 1);
          clk, reset : in bit );
end entity reg;

```

```
architecture behavioral of reg is  
begin  
  behavior : process (clk, reset) is  
    constant zero : bit_vector(0 to width - 1) := (others => '0');  
    begin  
      if reset = '1' then  
        q <= zero;  
      elsif clk'event and clk = '1' then  
        q <= d;  
      end if;  
    end process behavior;  
end architecture behavioral;
```

An entity and architecture body for a register with parameterized port size.
