

Multiprocessor Systems

Chapter 8, 8.1

Learning Outcomes

- An understanding of the structure and limits of multiprocessor hardware.
- An appreciation of approaches to operating system support for multiprocessor machines.
- An understanding of issues surrounding and approaches to construction of multiprocessor synchronisation primitives.

CPU clock-rate increase slowing

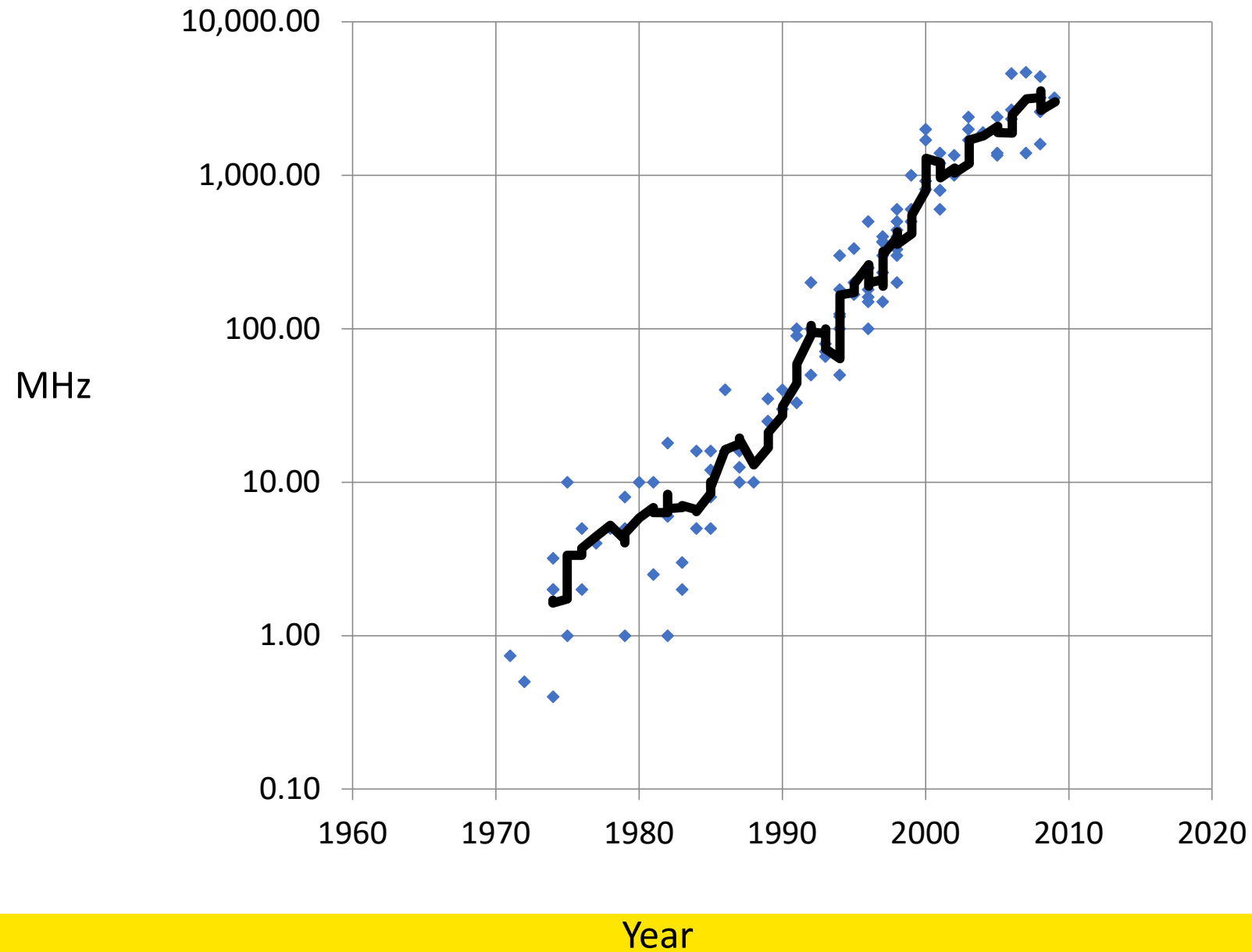

Multiprocessor System

- We will look at *shared-memory multiprocessors*
 - More than one processor sharing the same memory
- A single CPU can only go so fast
 - Use more than one CPU to improve performance
 - Assumes
 - Workload can be parallelised
 - Workload is not I/O-bound or memory-bound
- Disks and other hardware can be expensive
 - Can share hardware between CPUs

Amdahl's law

- Given a proportion P of a program that can be made parallel, and the remaining serial portion $(1-P)$, speedup by using N processors



$$\frac{1}{(1-P) + \frac{P}{N}}$$

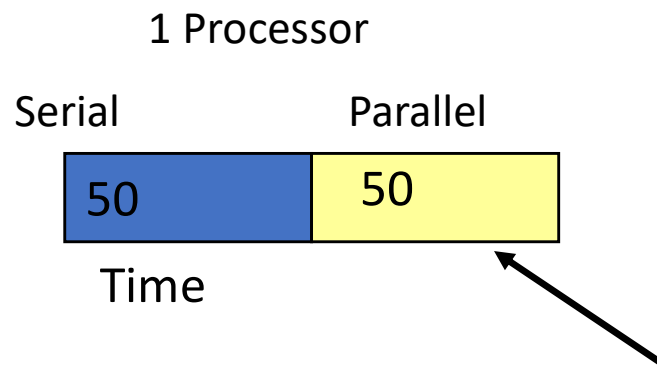

⇒

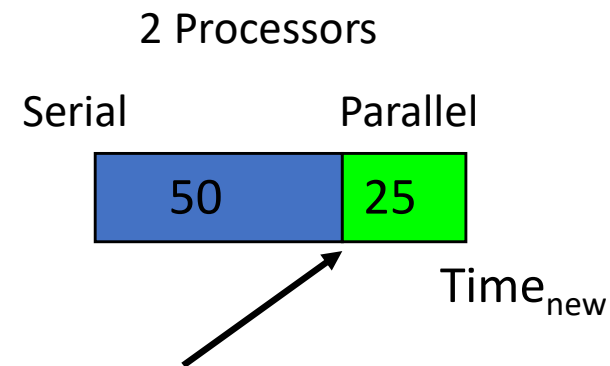

$$\text{Speedup} = 1 / (0.5 + 0.5/2) = 1.33\dots$$

Amdahl's law

- Given a proportion P of a program that can be made parallel, and the remaining serial portion $(1-P)$, speedup by using N processors



$$\frac{1}{(1-P) + \frac{P}{N}}$$

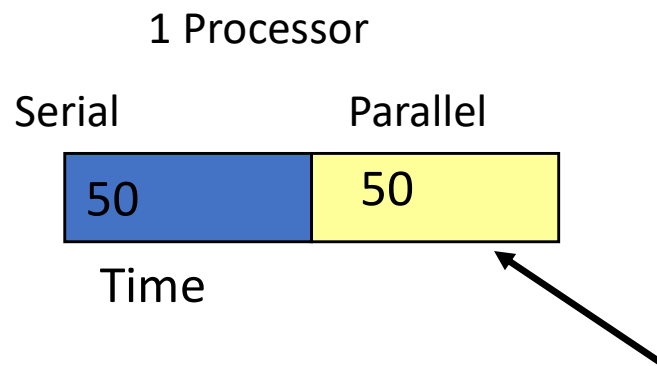

\Rightarrow

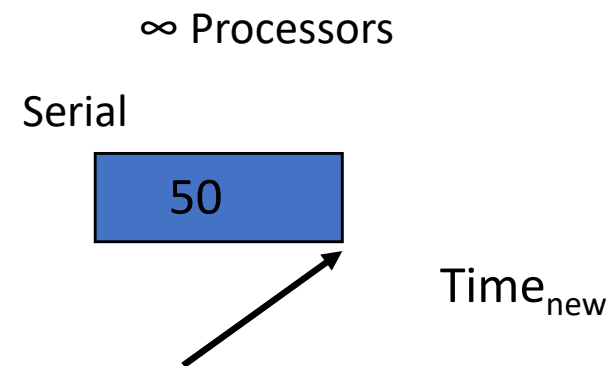

$$\text{Speedup} = 1 / (0.5 + 0) = 2$$

Bus-Based Uniform Memory Access Multiprocessors

- Simplest MP is more than one processor on a single bus connect to memory
 - Access to all memory occurs at the same speed for all processors.
 - Bus bandwidth becomes a bottleneck with more than just a few CPUs

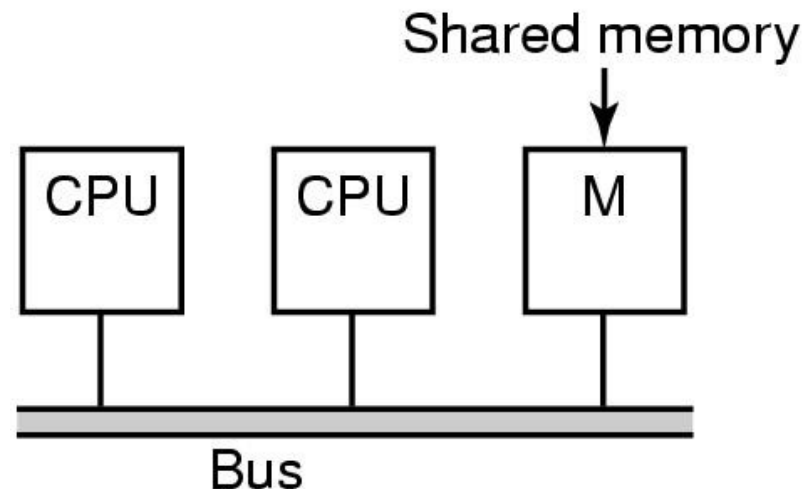

Multiprocessor caches

- Each processor has a cache to reduce its need for access to memory
 - Hope is most accesses are to the local cache
 - Bus bandwidth still becomes a bottleneck with many CPUs

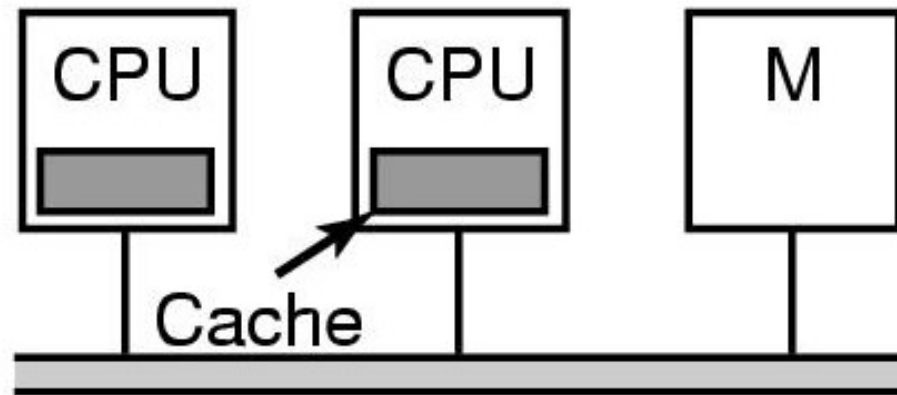

Cache Consistency

- What happens if one CPU writes to address 0x1234 (and it is stored in its cache) and another CPU reads from the same address (and gets what is in its cache)?

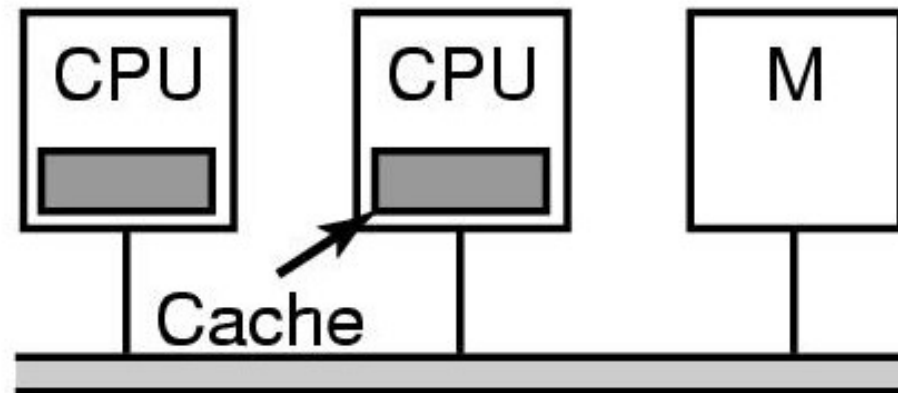

(b)

Cache Consistency

- Cache consistency is usually handled by the hardware.
 - Writes to one cache propagate to, or invalidate appropriate entries on other caches
 - Cache transactions also consume bus bandwidth

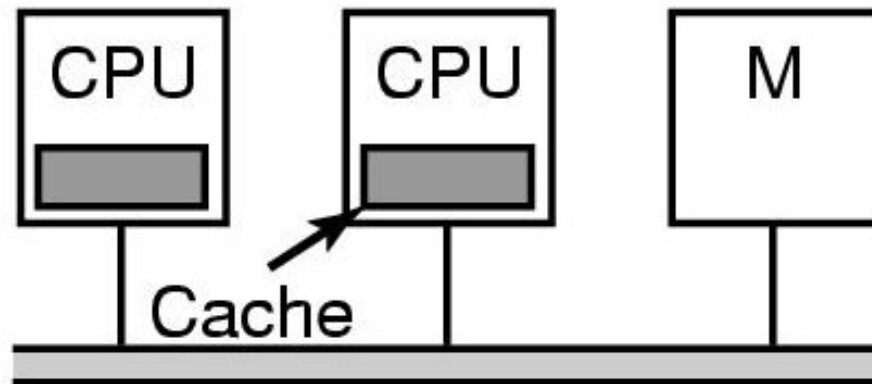

(b)

Multi-core Processor

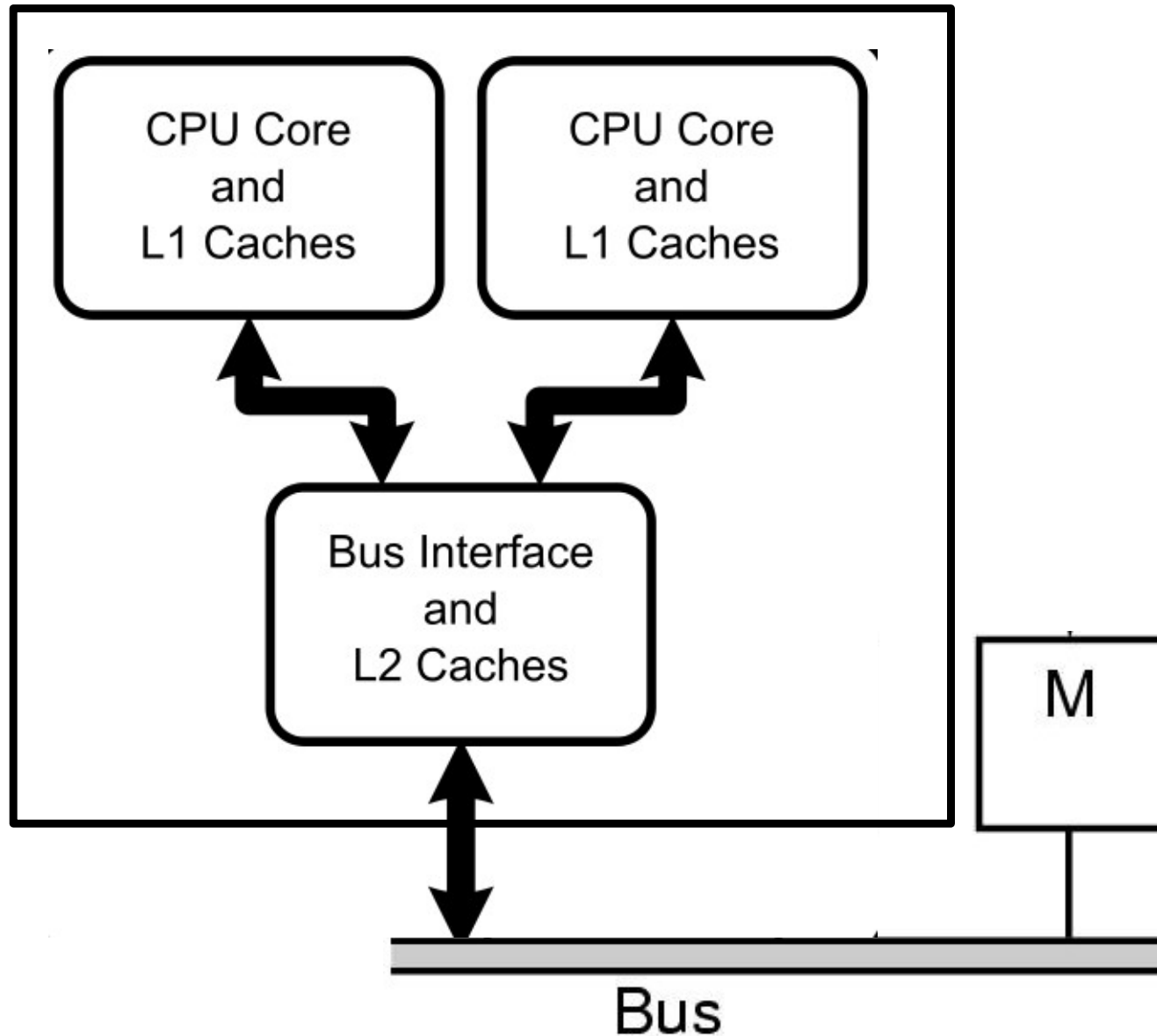

Bus-Based UMA Multiprocessors

- With only a single shared bus, scalability can be limited by the bus bandwidth of the single bus
 - Caching only helps so much
- Alternative bus architectures do exist.
 - They improve bandwidth available
 - Don't eliminate constraint that bandwidth is limited

Summary

- Multiprocessors can
 - Increase computation power beyond that available from a single CPU
 - Share resources such as disk and memory
- However
 - Assumes parallelizable workload to be effective
 - Assumes not I/O bound
 - Shared buses (bus bandwidth) limits scalability
 - Can be reduced via hardware design
 - Can be reduced by carefully crafted software behaviour
 - Good cache locality together with limited data sharing where possible

Question

- How do we construct an OS for a multiprocessor?
 - What are some of the issues?

Each CPU has its own OS?

- Statically allocate physical memory to each CPU
- Each CPU runs its own independent OS
- Share peripherals
- Each CPU (OS) handles its processes system calls

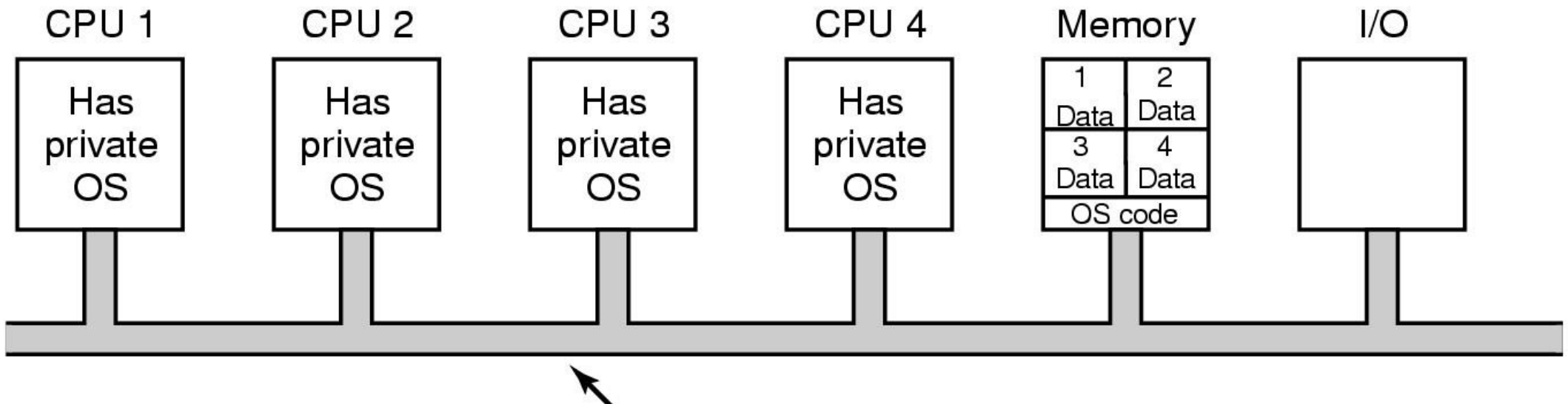

Each CPU has its own OS

- Used in early multiprocessor systems to 'get them going'
 - Simpler to implement
 - Avoids CPU-based concurrency issues by not sharing
 - Scales – no shared serial sections
 - Modern analogy, virtualisation in the cloud.

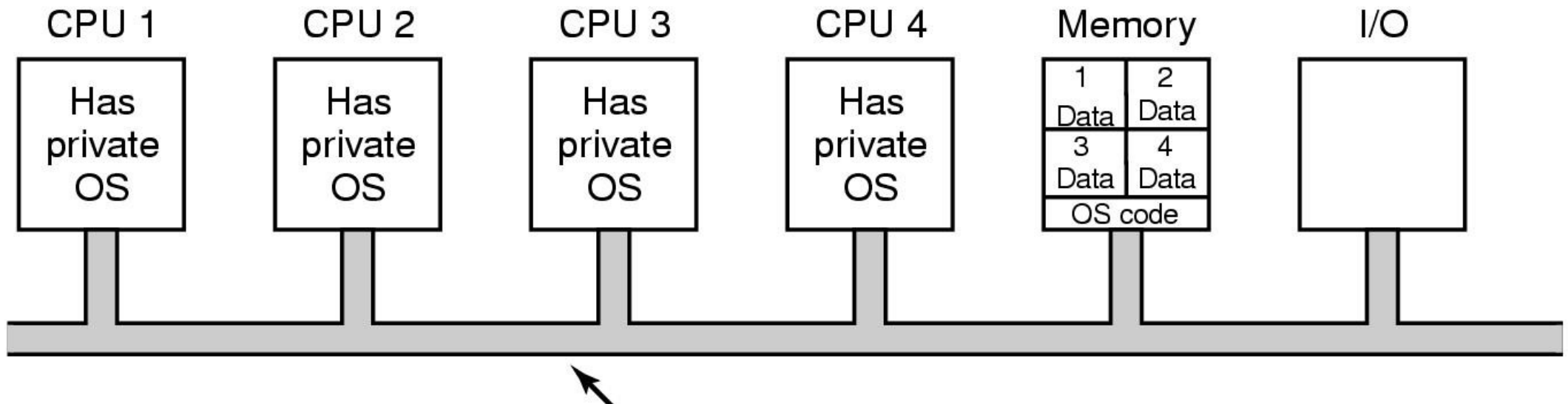

Issues

- Each processor has its own scheduling queue
 - We can have one processor overloaded, and the rest idle
- Each processor has its own memory partition
 - We can have one processor thrashing, and the others with free memory
 - No way to move free memory from one OS to another

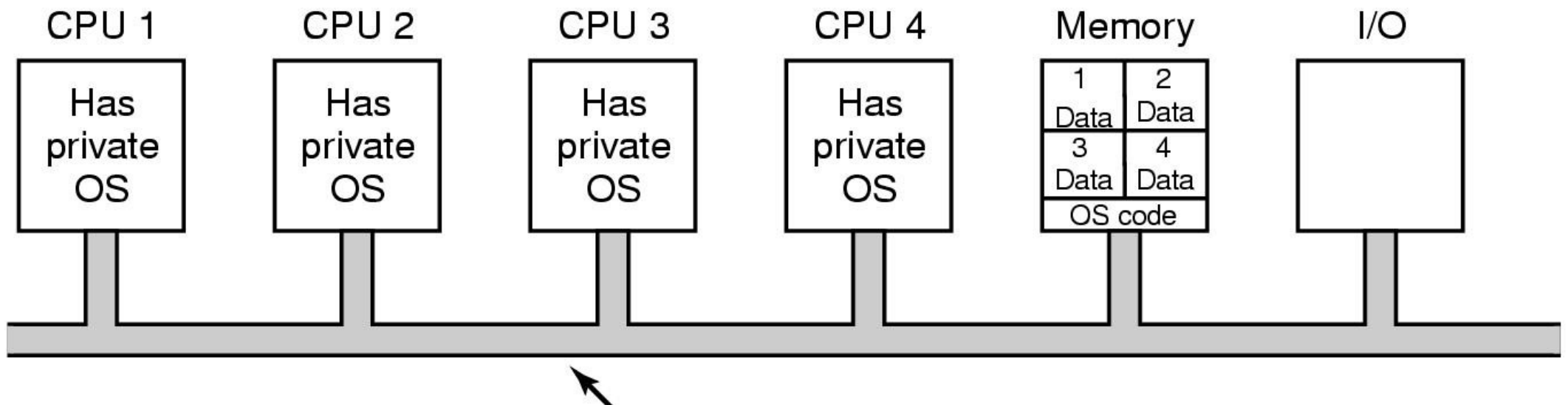

Symmetric Multiprocessors (SMP)

- OS kernel run on all processors
 - Load and resource are balance between all processors
 - Including kernel execution
- Issue: *Real* concurrency in the kernel
 - Need carefully applied synchronisation primitives to avoid disaster

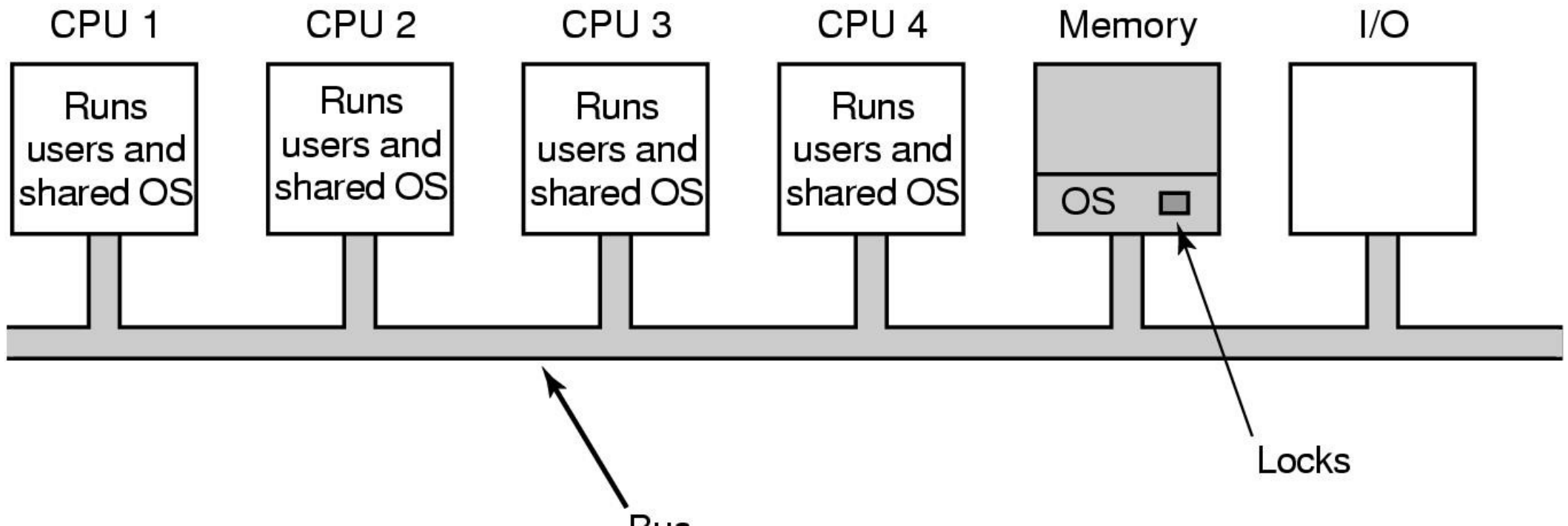

Symmetric Multiprocessors (SMP)

- One alternative: A single mutex that make the entire kernel a large critical section
 - Only one CPU can be in the kernel at a time
 - The “big lock” becomes a bottleneck when in-kernel processing exceeds what can be done on a single CPU

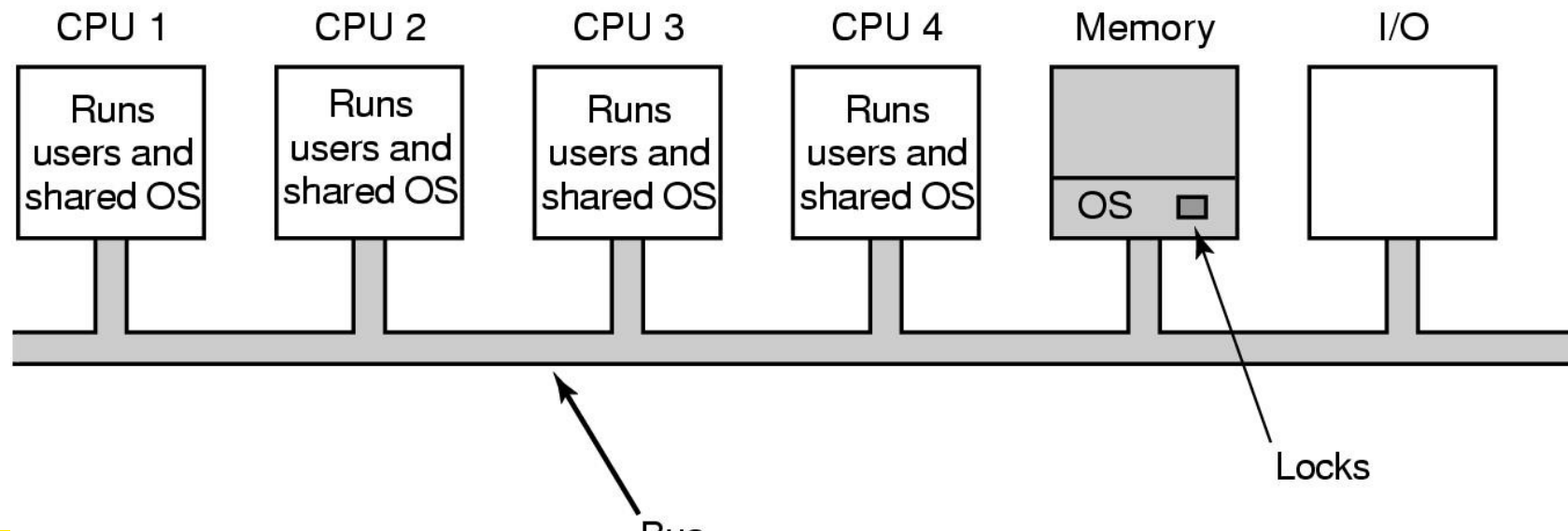

Symmetric Multiprocessors (SMP)

- Better alternative: identify largely independent parts of the kernel and make each of them their own critical section
 - Allows more parallelism in the kernel
- Issue: Difficult task
 - Code is mostly similar to uniprocessor code
 - Hard part is identifying independent parts that don't interfere with each other
 - Remember all the inter-dependencies between OS subsystems.

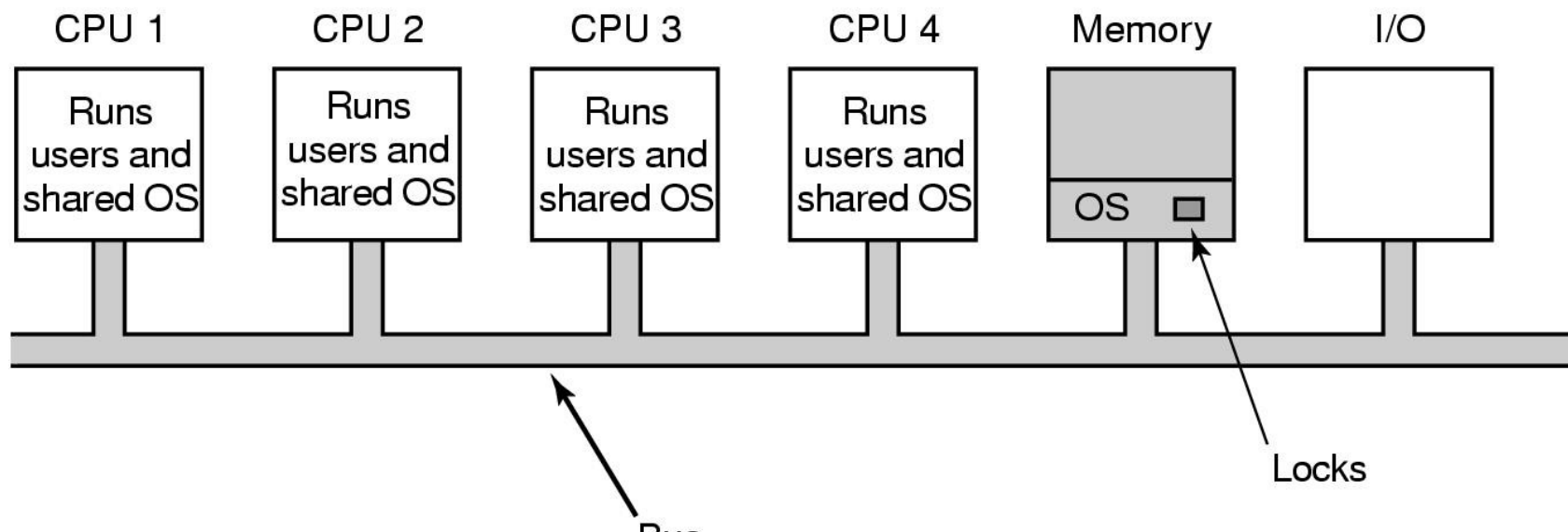

Symmetric Multiprocessors (SMP)

- Example:
 - Associate a mutex with independent parts of the kernel
 - Some kernel activities require more than one part of the kernel
 - Need to acquire more than one mutex
 - Great opportunity to deadlock!!!!
 - Results in potentially complex lock ordering schemes that must be adhered to

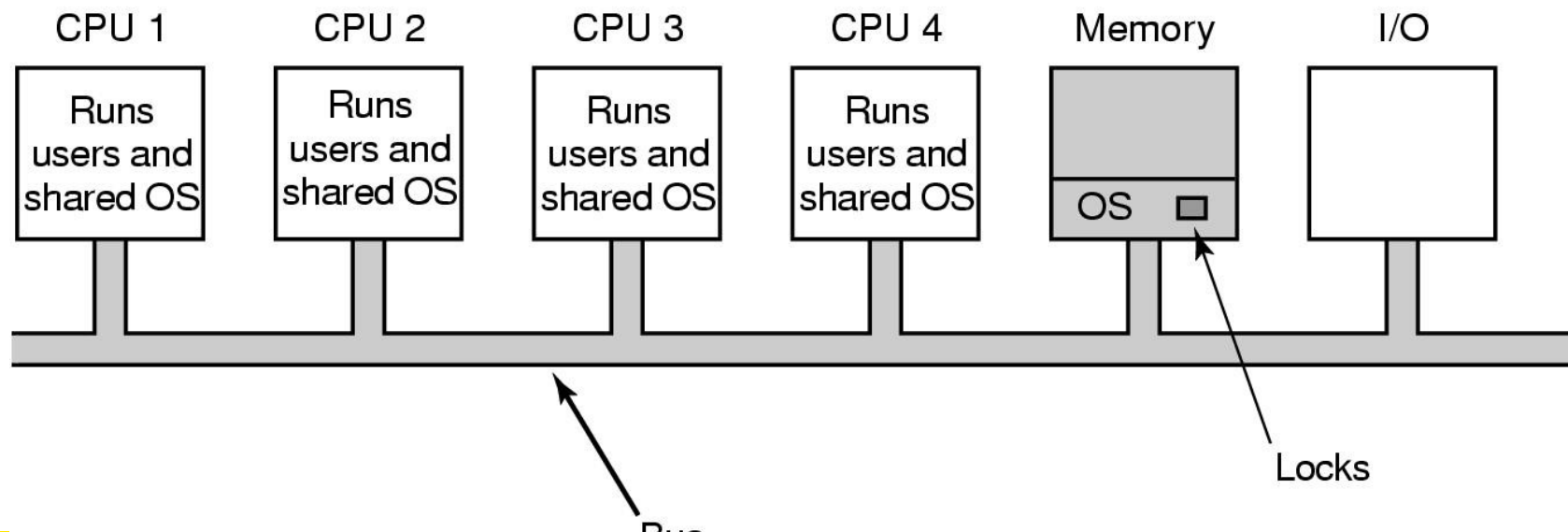

Symmetric Multiprocessors (SMP)

- Example:
 - Given a “big lock” kernel, we divide the kernel into two independent parts with a lock each
 - Good chance that one of those locks will become the next bottleneck
 - Leads to more subdivision, more locks, more complex lock acquisition rules
 - Subdivision in practice is (in reality) making more code multithreaded (parallelised)

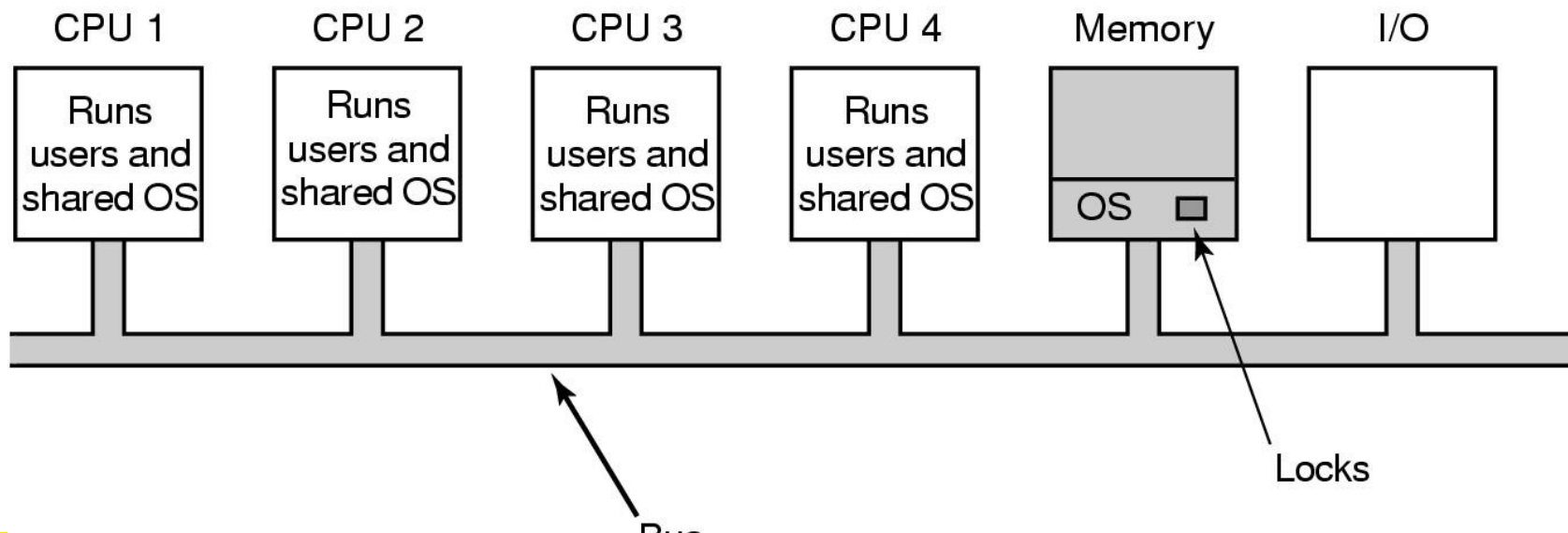

Real life Scalability Example

- Early 1990's, CSE wanted to run 80 X-Terminals off one or more server machines
- Winning tender was a 4-CPU bar-fridge-sized machine with 256M of RAM
 - Eventual config 6-CPU and 512M of RAM
 - Machine ran fine in all pre-session testing

Real life Scalability Example

- Students + assignment deadline = machine unusable

Real life Scalability Example

- To fix the problem, the tenderer supplied more CPUs to improve performance (number increased to 8)
 - No change????
- Eventually, machine was replaced with
 - Three 2-CPU pizza-box-sized machines, each with 256M RAM
 - Cheaper overall
 - Performance was dramatically improved!!!!
 - Why?

Real life Scalability Example

- Paper:
 - Ramesh Balan and Kurt Gollhardt, “A Scalable Implementation of Virtual Memory HAT Layer for Shared Memory Multiprocessor Machines”, Proc. 1992 Summer USENIX conference
- The 4-8 CPU machine hit a bottleneck in the single threaded VM code
 - Adding more CPUs simply added them to the wait queue for the VM locks, and made others wait longer
- The 2 CPU machines did not generate that much lock contention and performed proportionally better.

Lesson Learned

- Building scalable multiprocessor kernels is hard
- Lock contention can limit overall system performance

SMP Linux similar evolution

- Linux 2.0 Single kernel big lock (1996)
- Linux 2.2 Big lock with interrupt handling locks
- Linux 2.4 Big lock plus some subsystem locks
- Linux 2.6 most code now outside the big lock, data-based locking, lots of scalability tuning, etc, etc..
- Big lock removed in 2011 in kernel version 2.6.39

Multiprocessor Synchronisation

- Given we need synchronisation, how can we achieve it on a multiprocessor machine?
 - Unlike a uniprocessor, disabling interrupts does not work.
 - **It does not prevent other CPUs from running in parallel**
 - Need special hardware support

Recall Mutual Exclusion with Test-and-Set

enter_region:

```
TSL REGISTER,LOCK      | copy lock to register and set lock to 1
CMP REGISTER,#0        | was lock zero?
JNE enter_region       | if it was non zero, lock was set, so loop
RET | return to caller; critical region entered
```

leave_region:

```
MOVE LOCK,#0          | store a 0 in lock
RET | return to caller
```

Entering and leaving a critical region using the
TSL instruction

Test-and-Set

- Hardware guarantees that the instruction executes atomically on a CPU.
 - Atomically: As an indivisible unit.
 - The instruction can not stop half way through

Test-and-Set on SMP

- It does not work without some extra hardware support

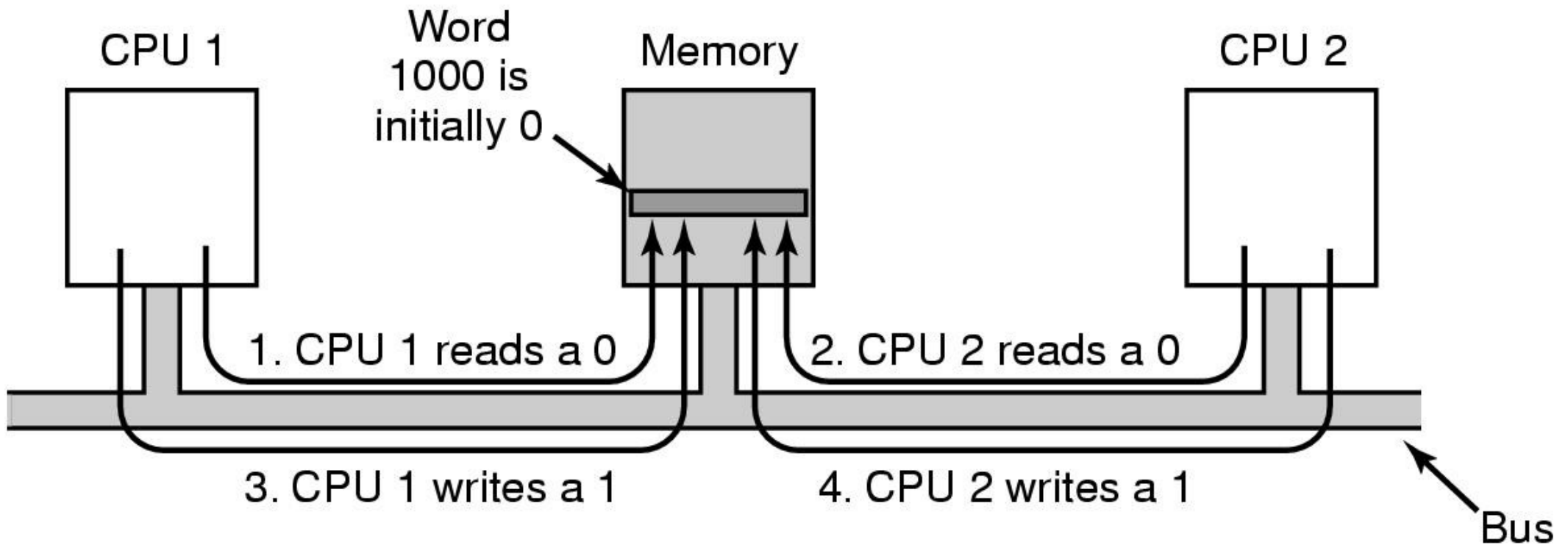

Test-and-Set on SMP

- A solution:
 - Hardware blocks all other CPUs from accessing the bus during the TSL instruction to prevent memory accesses by any other CPU.
 - TSL has mutually exclusive access to memory for duration of instruction.

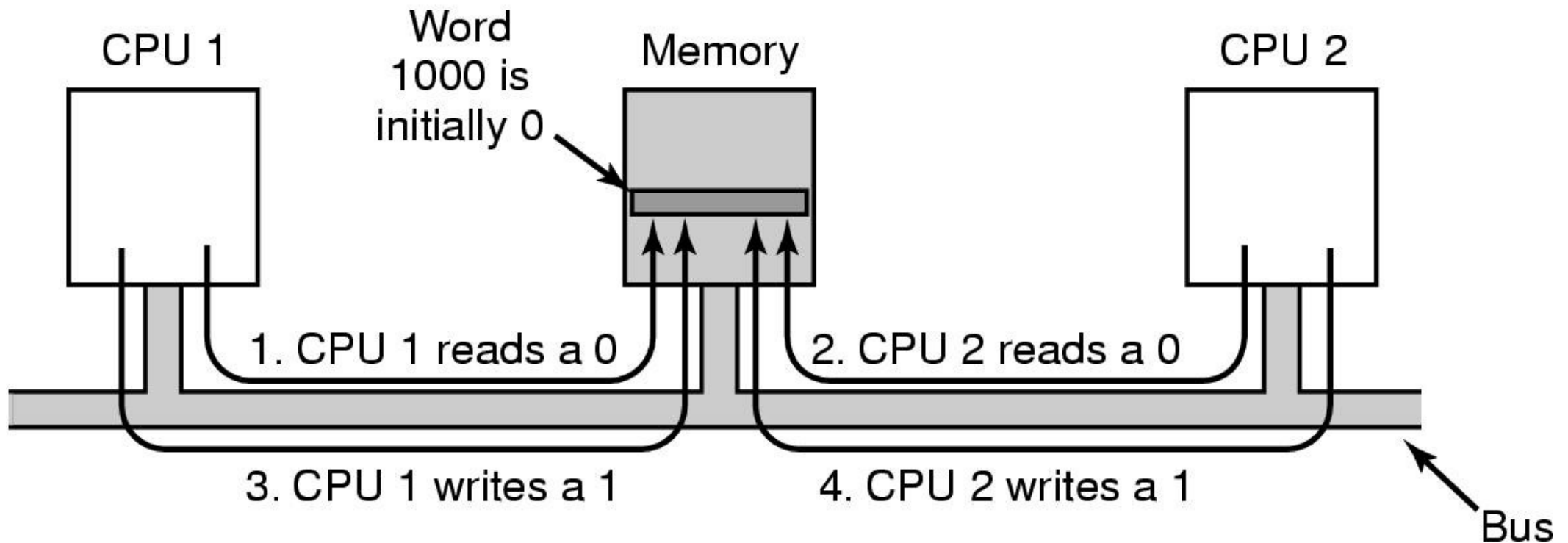

Test-and-Set on SMP

- Test-and Set is a busy-wait synchronisation primitive
 - Called a *spinlock*
- Issue:
 - Lock contention leads to spinning on the lock
 - Spinning on a lock requires blocking the bus which slows all other CPUs down
 - Independent of whether other CPUs need a lock or not
 - Causes bus contention

Test-and-Set on SMP

- Caching does not help reduce bus contention
 - Either TSL still blocks the bus
 - Or TSL requires exclusive access to an entry in the local cache
 - Requires invalidation of same entry in other caches, and loading entry into local cache
 - Many CPUs performing TSL simply bounce a single exclusive entry between all caches using the bus

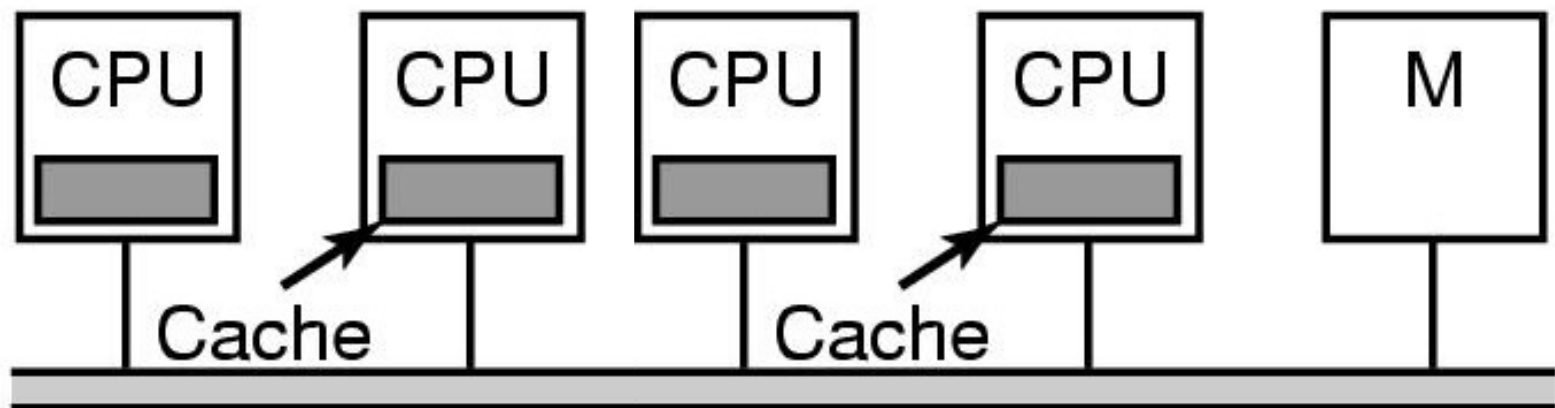

Reducing Bus Contention

- Read before TSL
 - Spin reading the lock variable waiting for it to change
 - When it does, use TSL to acquire the lock
- Allows lock to be shared read-only in all caches until its released
 - no bus traffic until actual release
- No race conditions, as acquisition is still with TSL.

```
start:
```

```
while (lock == 1);
```

```
r = TSL(lock)
```

```
if (r == 1)
```

```
goto start;
```

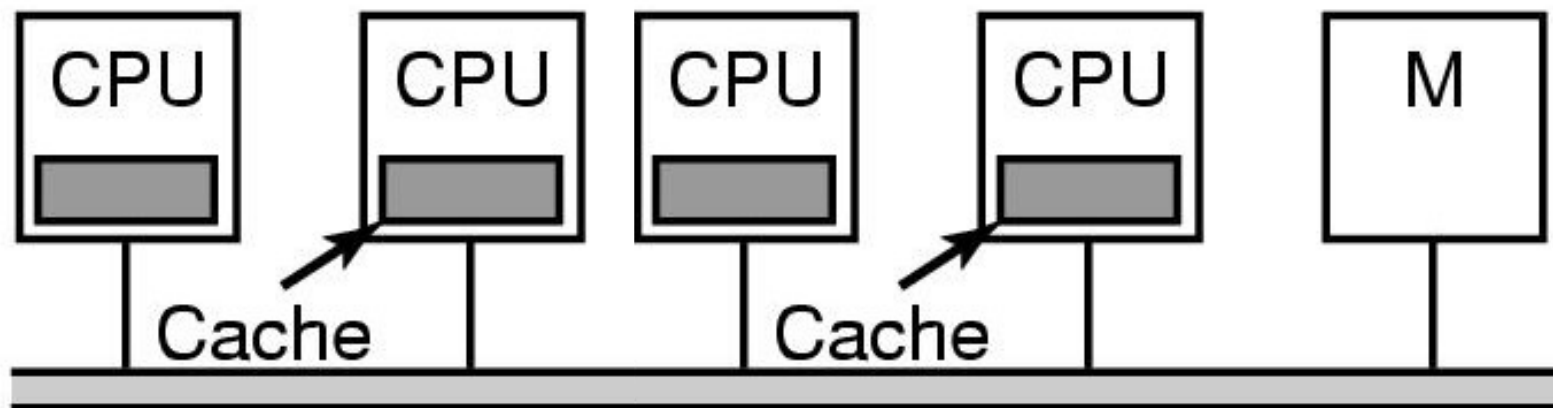

Thomas Anderson, “The Performance of Spin Lock Alternatives for Shared-Memory Multiprocessors”, *IEEE Transactions on Parallel and Distributed Systems*, Vol 1, No. 1, 1990

Compares Simple Spinlocks

- Test and Set

```
void lock (volatile lock_t *l) {  
    while (test_and_set(l)) ;  
}
```

- Read before Test and Set

```
void lock (volatile lock_t *l) {  
    while (*l == BUSY || test_and_set(l)) ;  
}
```

Benchmark

```
for i = 1 .. 1,000,000 {  
  lock(1)  
  crit_section()  
  unlock()  
  compute()  
}
```

- Compute chosen from uniform random distribution of mean 5 times critical section
- Measure elapsed time on Sequent Symmetry (20 CPU 30386, coherent write-back invalidate caches)

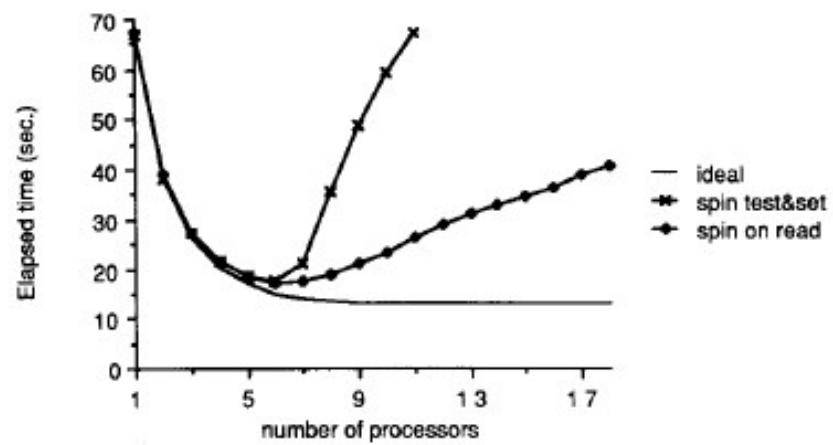

Results

- Test and set performs poorly once there is enough CPUs to cause contention for lock
 - Expected
- Read before Test and Set performs better
 - Performance less than expected
 - Still significant contention on lock when CPUs notice release and all attempt acquisition
- Critical section performance degenerates
 - Critical section requires bus traffic to modify shared structure
 - Lock holder competes with CPU that's waiting as they test and set, so the lock holder is slower
 - Slower lock holder results in more contention

Spinning Locks versus Blocking Locks

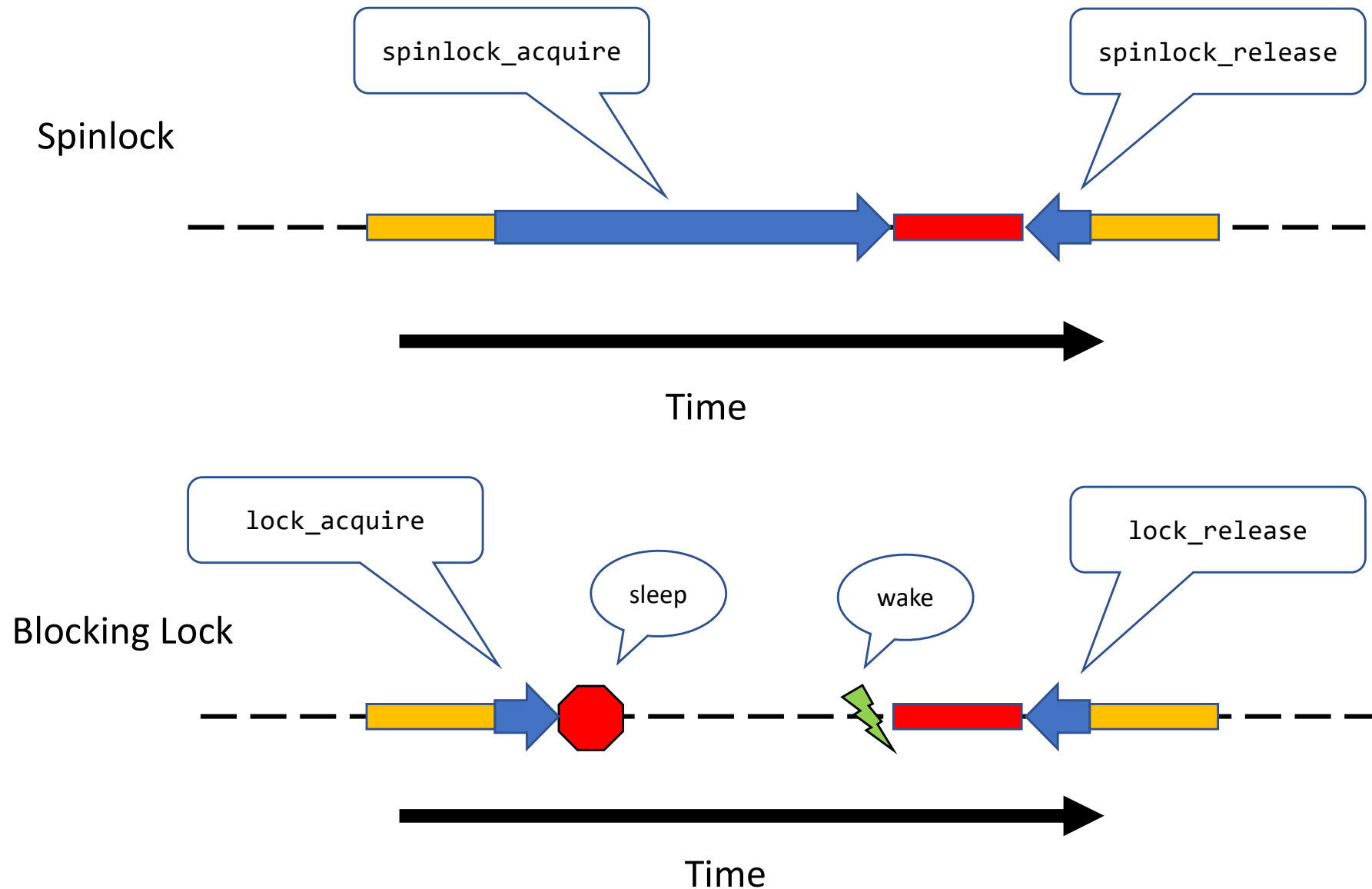

Uniprocessor: Spinning versus Blocking

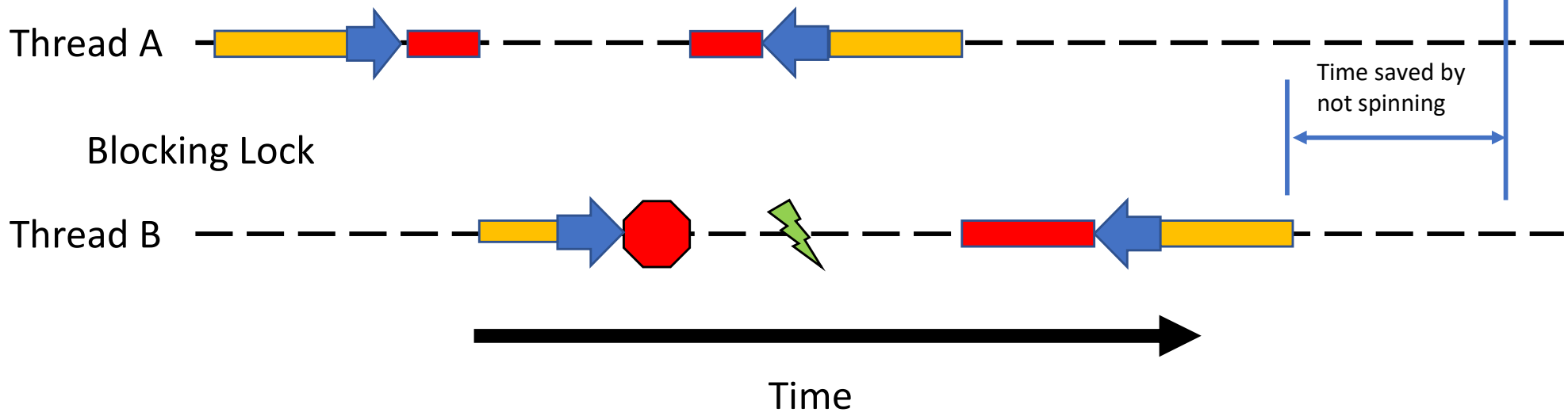
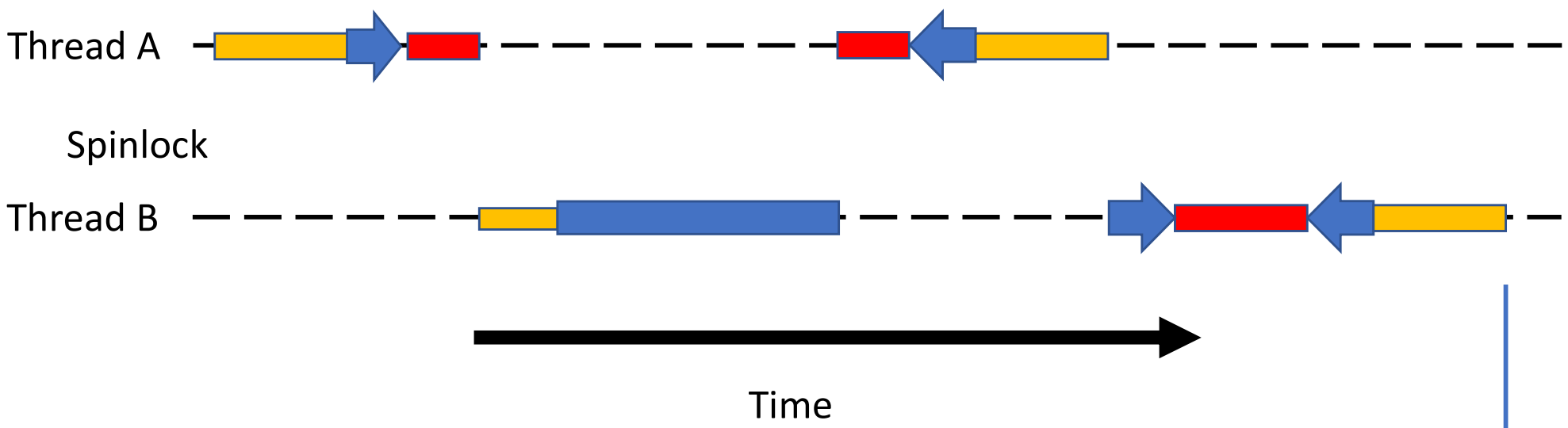

Spinning versus Blocking and Switching

- Spinning (busy-waiting) on a lock makes no sense on a uniprocessor
 - There was no other running process to release the lock
 - Blocking and (eventually) switching to the lock holder is the only sensible option.
- On SMP systems, the decision to spin or block is not as clear.
 - The lock is held by another running CPU and will be freed without necessarily switching away from the requestor

Multiprocessor: Spinning versus Blocking

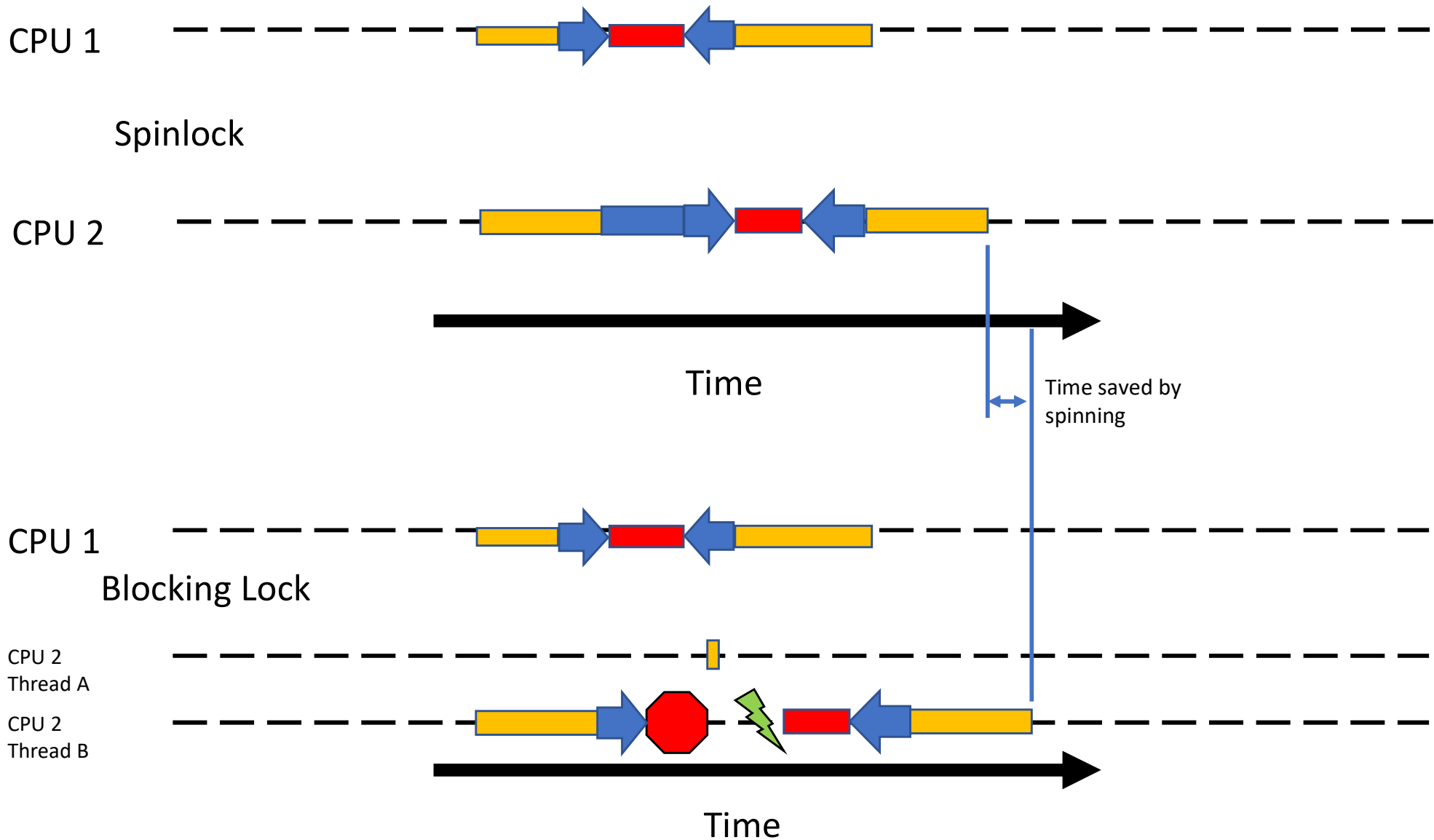

Multiprocessor: Spinning versus Blocking

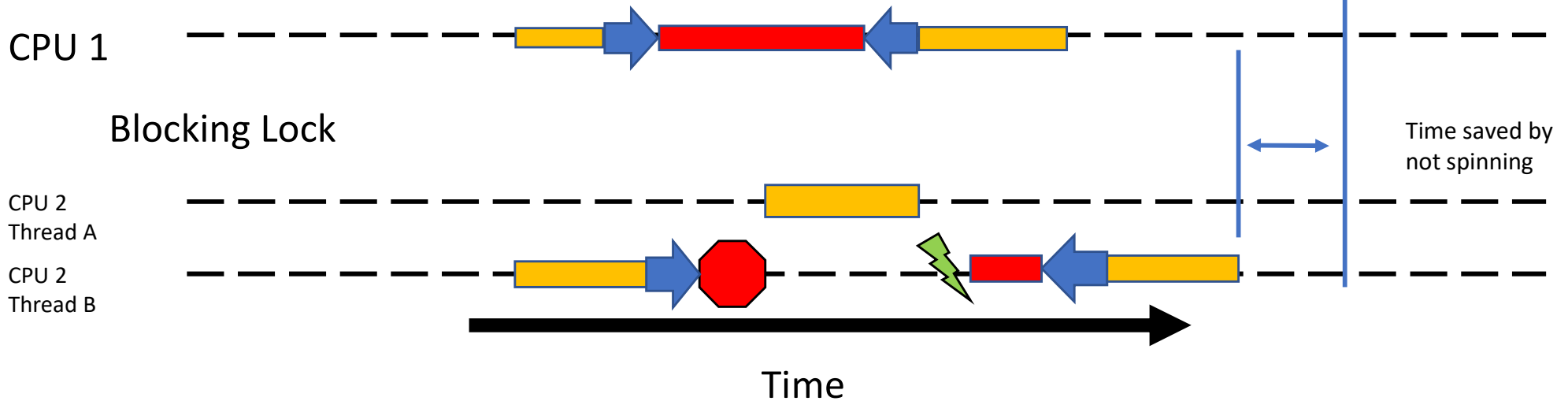
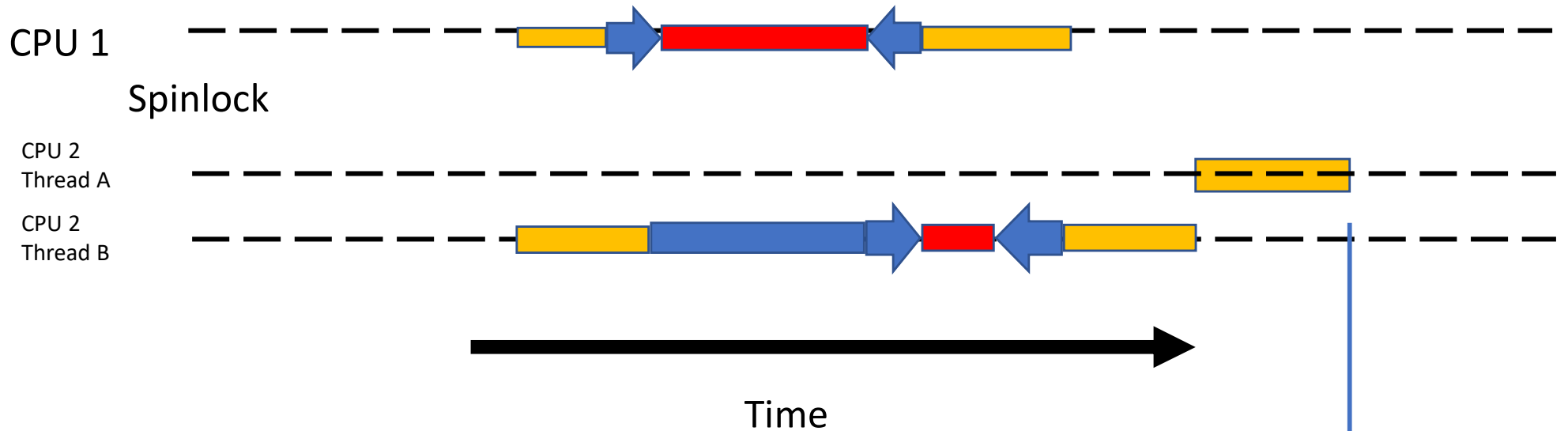

Spinning versus Switching

- Blocking and switching
 - to another process takes time
 - Save context and restore another
 - Cache contains current process not new process
 - Adjusting the cache working set also takes time
 - TLB is similar to cache
 - Switching back when the lock is free encounters the same again
 - Spinning wastes CPU time directly
 - Trade off
 - If lock is held for less time than the overhead of switching to and back
 - ⇒ It's more efficient to spin
- ⇒ Spinlocks expect critical sections to be short
- ⇒ No waiting for I/O within a spinlock
 - ⇒ No nesting locks within a spinlock

Preemption and Spinlocks

- Critical sections synchronised via spinlocks are expected to be short
 - Avoid other CPUs wasting cycles spinning
 - What happens if the spinlock holder is preempted at end of holder's timeslice
 - Mutual exclusion is still guaranteed
 - Other CPUs will spin until the holder is scheduled again!!!!
- ⇒ Spinlock implementations disable interrupts in addition to acquiring locks
- avoids lock-holder preemption
 - avoids spinning on a uniprocessor