

## COMP 9519: Tutorial 1

1. An RGB image is converted to YUV 4:2:2 format. “*The YUV 4:2:2 version of the image is of lower quality than the RGB version of the image*”. Is this statement TRUE or FALSE? Give reasons for your answer.
2. Shown below are two 8x8 image blocks.

10	10	10	10	11	11	13	13
10	10	10	11	12	13	13	15
10	11	11	12	13	13	15	15
11	11	12	13	13	15	15	16
11	12	12	14	14	15	16	16
12	12	14	14	15	16	16	17
12	14	14	15	16	17	17	17
14	14	16	16	17	17	17	17

Block A

10	11	12	13	14	15	16	17
10	11	12	13	14	15	16	17
10	11	12	13	14	15	16	17
10	11	12	13	14	15	16	17
10	11	12	13	14	15	16	17
10	11	12	13	14	15	16	17
10	11	12	13	14	15	16	17
10	11	12	13	14	15	16	17

Block B

Answer the following:

- i) Calculate the entropy for each block.
- ii) If both blocks were directly encoded (i.e. no DCT or quantization) using run-length coding based on a zig-zag scanning pattern, which block would produce a lower number of bits? Justify your answer.

3. Based on 2x2 macroblocks (MB), the X motion estimation algorithm (X-MEN) searches for the best matching motion vector in the following locations:  $\{0,0\}$ ,  $\{-2,-2\}$ ,  $\{+2,-2\}$ ,  $\{-2,+2\}$ ,  $\{+2,+2\}$ . These locations are relative to the current MB and corresponds to the center, top-left, top-right, bottom-left and bottom-right areas. Assume a search range of  $\{-2,+2\}$ , with the current MB at the current frame (frame[N]) as:

113	119
238	107

And the reference frame (frame[N-1]) is:

216	77	87	44	149	203	82	94	150	31	215	41	40	251	49	95
134	138	136	250	108	15	245	147	15	115	44	223	49	141	231	108
52	38	185	69	131	154	185	115	94	183	44	61	108	102	145	152
171	178	79	64	85	13	105	11	161	228	254	165	218	51	161	144
214	96	214	223	110	106	190	7	183	70	112	247	125	159	60	183
5	219	145	188	58	78	68	80	177	65	87	170	208	187	140	130
174	218	94	35	148	223	112	3	21	221	80	222	117	96	238	198
97	151	179	3	194	4	238	98	116	59	93	3	117	3	85	125
212	127	139	228	135	196	174	174	113	205	100	35	115	107	167	47
128	229	113	51	163	248	54	24	90	232	151	209	105	192	100	179
181	210	177	76	53	252	214	9	39	59	31	110	230	202	160	251
109	164	158	169	97	201	160	156	172	61	10	227	1	235	178	206
78	209	203	73	200	112	34	155	178	13	117	187	76	215	101	179
48	168	244	120	174	127	53	4	186	20	222	175	13	94	105	124
49	87	133	17	118	55	155	4	122	163	238	88	177	158	167	29
174	74	224	252	145	164	161	48	141	49	67	42	166	186	214	170

Where the shaded MB is the relative position of the current MB in frame[N] on the reference frame (also called the co-located MB). Answer the following questions:

- i) Calculate the sum of absolute differences at each search location of X-MEN.
- ii) What will be the best motion vector given by X-MEN? Justify your answer.

4. The video encoding process blocks are shown below:

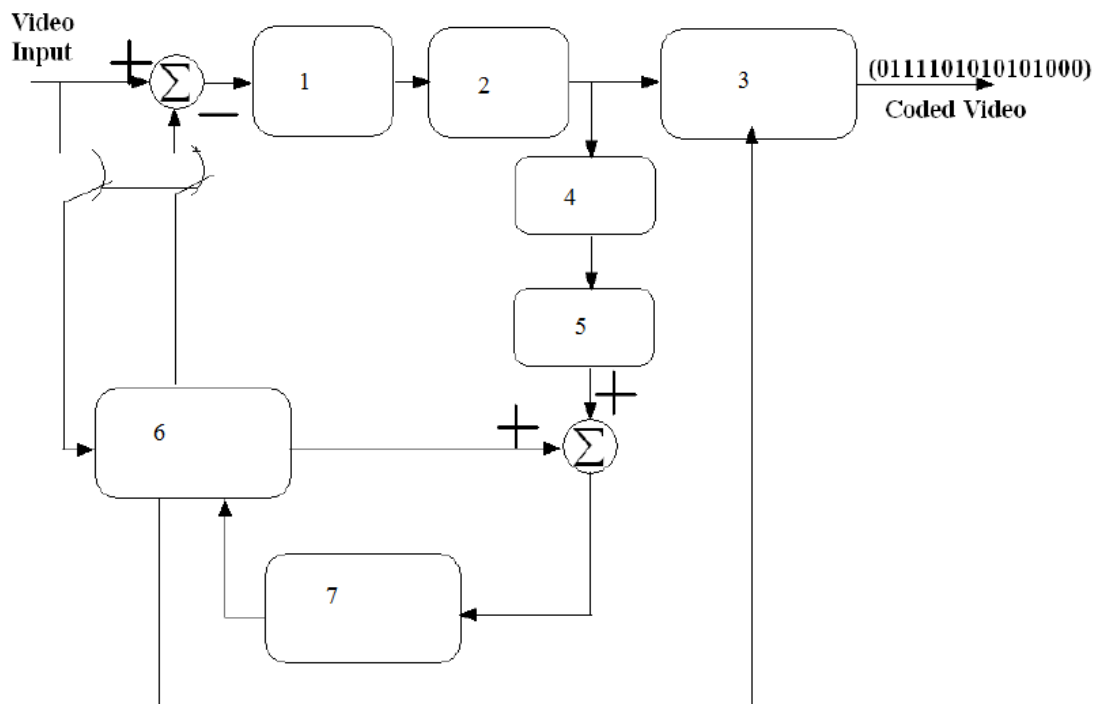

Answer the following questions:

- i) Which block(s) will information loss occur?
- ii) Which block(s) contain the decoded version of the previous frame (Frame[N-1])?
- iii) Which block(s) contain the motion compensated version of the current frame (Frame[N])?
- iv) Assume the current frame is inter-coded (i.e. coded using motion estimation), what will the coded video consist of?