

Abstract Processes in the Absence of Conflicts in General Place/Transition Systems*

Rob van Glabbeek^{1,2}, Ursula Goltz³ & Jens-Wolfhard Schicke-Uffmann³

¹ Data61, CSIRO, Sydney, Australia

² School of Comp. Sc. and Engineering, Univ. of New South Wales, Sydney, Australia

³ Institute for Programming and Reactive Systems, TU Braunschweig, Germany

Abstract. Goltz and Reisig generalised Petri’s concept of *processes* of one-safe Petri nets to general nets where places carry multiple tokens. *BD-processes* are equivalence classes of Goltz-Reisig processes connected through the swapping transformation of Best and Devillers; they can be considered as an alternative representation of runs of nets. Here we present an order respecting bijection between the BD-processes and the *FS-processes* of a countable net, the latter being defined—in an analogous way—as equivalence classes of firing sequences. Using this, we show that a countable net without binary conflicts has a (unique) largest BD-process.

1 Introduction

For the basic class of Petri nets, the *condition/event systems*, there is a well established notion of *process* [Pet77], modelling runs of the represented system. This paper continues the adaptation of this notion of process to general *place/transition systems* (*P/T systems*).

Goltz and Reisig proposed a notion of process for P/T systems which is rather discriminating [GR83]. Depending on which of several “identical” tokens you choose for firing a transition, you may get different processes, with different causal dependencies. We call this notion a *GR-process*.

Best and Devillers [BD87] defined a swapping transformation on GR-processes that identifies GR-processes differing only in the choice which token was removed from a place. They proposed an equivalence notion \equiv_1^∞ on GR-processes, where \equiv_1^∞ -equivalent processes intuitively can be converted into each other through ‘infinitely many’ swapping transformations. We address an \equiv_1^∞ -equivalence class of GR-processes as a *BD-process*.

GR-processes can be seen as an unsatisfactory formalisation of the intuitive concept of a run, since there exist conflict-free¹ systems with multiple maximal GR-processes. We refer to [GGS11a,GGS21] and the many references therein for an example and further discussion. On the other hand, BD-processes can

* This work was partially supported by the DFG (German Research Foundation).

¹ Intuitively, a *conflict* denotes any situation in which there is a choice to resolve. A formalisation of this notion [Gol86,GGS21] occurs in Section 4.

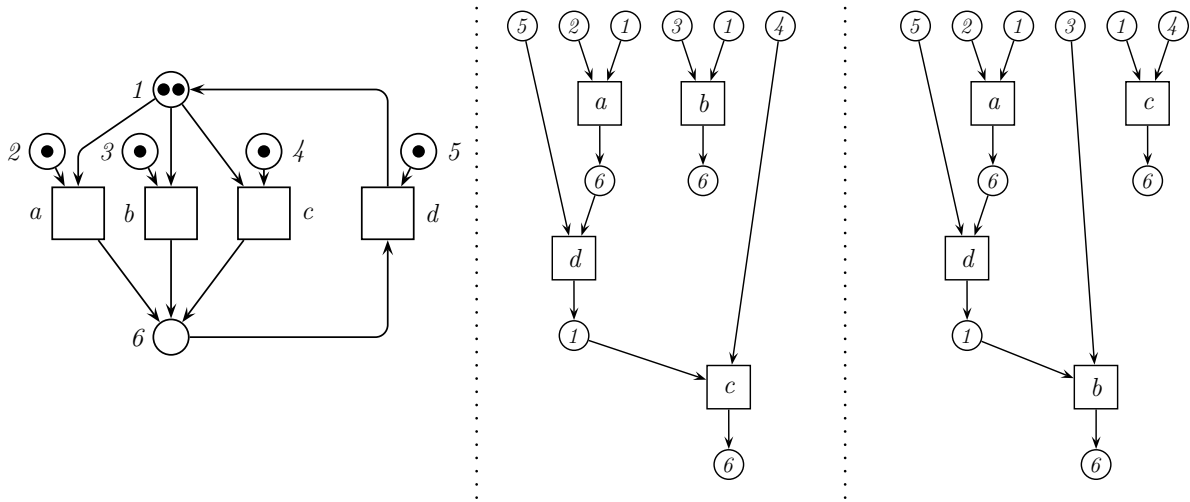

Fig. 1. A net together with two of its maximal GR-processes, which are identified by swapping equivalence.

be seen as unsatisfactory, because there exist systems which do have conflicts, yet still have a unique maximal BD-process. To illustrate this result, we recall in Fig. 1 an example due to Ochmański [Och89] — see also [DMM89, GGS11a]. In the initial situation only two of the three enabled transitions can fire, which constitutes a conflict. However, the equivalence \equiv_1^∞ obtained from the swapping transformation (formally defined in Section 3) identifies all possible maximal GR-processes—two of which are shown here—and hence yields only one complete abstract run of the system. We are not aware of a solution, i.e. any formalisation of the concept of a run of a net that allows only one complete run for a conflict-free net but allocates multiple complete runs to the net of Fig. 1.

In [GGS11a, GGS21] we propose a subclass of P/T systems, called *structural conflict nets*, more general than the well-known class of *safe nets*. On these nets BD-processes are a good formalisation of runs, for we showed that a structural conflict net has a largest BD-process if and only if the net is conflict-free.

The question remains what happens for general P/T systems. As we have illustrated above, systems with conflicts may still have one largest BD-process. In this paper we will show that the “if” part of the above-mentioned correspondence also holds for general countable P/T systems: a countable conflict-free P/T-system has a largest BD-process.²

However, it turns out that the proof of this result is much more complicated than the special case for structural conflict nets established in [GGS21].³

² In fact, we present a slightly stronger result, namely that a countable P/T-system without *binary* conflicts has a largest BD-process. We also give a counterexample showing that this stronger result needs the restriction to *countable* P/T systems. We do not know whether each uncountable P/T-system without any conflicts has a largest BD-process.

³ The proof of [GGS21, Theorem 2], creating a largest BD-process for any given structural conflict net, does not generalise beyond structural conflict nets. We did not find a better method for this generalisation than via the detour of FS-processes, as described below.

Best and Devillers [BD87] defined a swapping transformation also on the firing sequences of a net, allowing two adjacent transitions to be swapped if they can be fired concurrently. They proposed an equivalence notion \equiv_0^∞ on firing sequences, where \equiv_0^∞ -equivalent firing sequences intuitively can be converted into each other through ‘infinitely many’ swaps. We address an \equiv_0^∞ -equivalence class of firing sequences as an *FS-process*. Best and Devillers established a bijective correspondence between the BD-processes and the FS-processes of a countable net. Here we consider the natural preorders \sqsubseteq_1^∞ on GR-processes and \sqsubseteq_0^∞ on firing sequences with kernels \equiv_1^∞ and \equiv_0^∞ . They induce partial orders (also denoted \sqsubseteq_1^∞ and \sqsubseteq_0^∞) on BD-processes and FS-processes respectively. In Section 5 we prove that the bijective correspondence between the BD-processes and the FS-processes of a countable net respects this order, so that a countable net has a largest BD-process iff it has a largest FS-process. This result is interesting in its own right. Additionally we use it as a stepping stone for obtaining our main result discussed above, by showing that a countable conflict-free P/T-system has a largest FS-process.

The results of this paper appeared already in our technical report [GGs11b], although formulated and proven differently, since there we didn’t have the pre-order \sqsubseteq_1^∞ , introduced in [GGs21]. Our revised proofs are conceptually simpler, as they avoid the auxiliary concepts of BD-runs and FS-runs.

2 Place/transition systems⁴

We will employ the following notations for multisets.

Definition 1. Let X be a set.

- A *multiset* over X is a function $A: X \rightarrow \mathbb{N}$, i.e. $A \in \mathbb{N}^X$.
- $x \in X$ is an *element* of A , notation $x \in A$, iff $A(x) > 0$.
- For multisets A and B over X we write $A \subseteq B$ iff $A(x) \leq B(x)$ for all $x \in X$; $A \cup B$ denotes the multiset over X with $(A \cup B)(x) := \max(A(x), B(x))$, $A \cap B$ denotes the multiset over X with $(A \cap B)(x) := \min(A(x), B(x))$, $A + B$ denotes the multiset over X with $(A + B)(x) := A(x) + B(x)$, $A - B$ is given by $(A - B)(x) := A(x) \dot{-} B(x) = \max(A(x) - B(x), 0)$, and for $k \in \mathbb{N}$ the multiset $k \cdot A$ is given by $(k \cdot A)(x) := k \cdot A(x)$.
- The function $\emptyset: X \rightarrow \mathbb{N}$, given by $\emptyset(x) := 0$ for all $x \in X$, is the *empty* multiset over X .
- If A is a multiset over X and $Y \subseteq X$ then $A \upharpoonright Y$ denotes the multiset over Y defined by $(A \upharpoonright Y)(x) := A(x)$ for all $x \in Y$.
- The cardinality $|A|$ of a multiset A over X is given by $|A| := \sum_{x \in X} A(x)$.
- A multiset A over X is *finite* iff $|A| < \infty$, i.e., iff the set $\{x \mid x \in A\}$ is finite.

⁴ The material in Sections 2, 3.1 and 4 follows closely the presentation in [GGs11a], but needs to be included to make the paper self-contained.

- A function $\pi : X \rightarrow Y$ extends to multisets $A \in \mathbb{N}^X$ by $\pi(A)(y) = \sum_{x=\pi(x)} A(x)$. In this paper, this sum will always turn out to be finite.

Two multisets $A : X \rightarrow \mathbb{N}$ and $B : Y \rightarrow \mathbb{N}$ are *extensionally equivalent* iff $A \upharpoonright (X \cap Y) = B \upharpoonright (X \cap Y)$, $A \upharpoonright (X \setminus Y) = \emptyset$, and $B \upharpoonright (Y \setminus X) = \emptyset$. In this paper we often do not distinguish extensionally equivalent multisets. This enables us, for instance, to use $A \cup B$ even when A and B have different underlying domains. With $\{x, x, y\}$ we will denote the multiset over $\{x, y\}$ with $A(x)=2$ and $A(y)=1$, rather than the set $\{x, y\}$ itself. A multiset A with $A(x) \leq 1$ for all x is identified with the set $\{x \mid A(x) = 1\}$.

Below we define place/transition systems as net structures with an initial marking. In the literature we find slight variations in the definition of P/T systems concerning the requirements for pre- and postsets of places and transitions. In our case, we do allow isolated places. For transitions we allow empty postsets, but require at least one preplace, thus avoiding problems with infinite self-concurrency. Moreover, following [BD87], we restrict attention to nets of *finite synchronisation*, meaning that each transition has only finitely many pre- and postplaces. Arc weights are included by defining the flow relation as a function to the natural numbers. For succinctness, we will refer to our version of a P/T system as a *net*.

Definition 2.

A *net* is a tuple $N = (S, T, F, M_0)$ where

- S and T are disjoint sets (of *places* and *transitions*),
- $F : ((S \times T) \cup (T \times S)) \rightarrow \mathbb{N}$ (the *flow relation* including *arc weights*), and
- $M_0 : S \rightarrow \mathbb{N}$ (the *initial marking*)

such that for all $t \in T$ the set $\{s \mid F(s, t) > 0\}$ is finite and non-empty, and the set $\{s \mid F(t, s) > 0\}$ is finite.

Graphically, nets are depicted by drawing the places as circles and the transitions as boxes. For $x, y \in S \cup T$ there are $F(x, y)$ arrows (*arcs*) from x to y .⁵ When a net represents a concurrent system, a global state of this system is given as a *marking*, a multiset of places, depicted by placing $M(s)$ dots (*tokens*) in each place s . The initial state is M_0 .

Definition 3. Let $N = (S, T, F, M_0)$ be a net and $x \in S \cup T$.

The multisets $\bullet x, x^\bullet : S \cup T \rightarrow \mathbb{N}$ are given by $\bullet x(y) = F(y, x)$ and $x^\bullet(y) = F(x, y)$ for all $y \in S \cup T$. If $x \in T$, the elements of $\bullet x$ and x^\bullet are called *pre-* and *postplaces* of x , respectively. These functions extend to finite multisets $X : S \cup T \rightarrow \mathbb{N}$ as usual, by $\bullet X := \sum_{x \in S \cup T} X(x) \cdot \bullet x$ and $X^\bullet := \sum_{x \in S \cup T} X(x) \cdot x^\bullet$.

The system behaviour is defined by the possible moves between markings M and M' , which take place when a finite multiset G of transitions *fires*. When

⁵ This is a presentational alternative for the common approach of having at most one arc from x to y , labelled with the *arcweight* $F(x, y) \in \mathbb{N}$.

firing a transition, tokens on preplaces are consumed and tokens on postplaces are created, one for every incoming or outgoing arc of t , respectively. Obviously, a transition can only fire if all necessary tokens are available in M in the first place. Definition 4 formalises this notion of behaviour.

Definition 4. Let $N = (S, T, F, M_0)$ be a net, $G \in \mathbb{N}^T$, G non-empty and finite, and $M, M' \in \mathbb{N}^S$.

G is a *step* from M to M' , written $M \xrightarrow{G}_N M'$, iff

- $\bullet G \subseteq M$ (G is *enabled*) and
- $M' = (M - \bullet G) + G^\bullet$.

We may leave out the subscript N if clear from context. For a word $\sigma = t_1 t_2 \dots t_n \in T^*$ we write $M \xrightarrow{\sigma} M'$ for

$$\exists M_1, M_2, \dots, M_{n-1}. M \xrightarrow{\{t_1\}} M_1 \xrightarrow{\{t_2\}} M_2 \dots M_{n-1} \xrightarrow{\{t_n\}} M'$$

When omitting σ or M' we always mean it to be existentially quantified. Likewise, for an infinite word $\sigma = t_1 t_2 t_3 \dots \in T^\omega$ we write $M \xrightarrow{\sigma}$ for

$$\exists M_1, M_2, \dots. M \xrightarrow{\{t_1\}} M_1 \xrightarrow{\{t_2\}} M_2 \xrightarrow{\{t_3\}} \dots$$

When $M_0 \xrightarrow{\sigma}_N$, the word $\sigma \in T^* \cup T^\omega$ is called a *firing sequence* of N . The set of all firing sequences of N is denoted by $\text{FS}^\infty(N)$, and the subset of finite firing sequences of N is denoted by $\text{FS}(N)$.

Note that steps are (finite) multisets, thus allowing self-concurrency. Also note that $M \xrightarrow{\{t,u\}}$ implies $M \xrightarrow{tu}$ and $M \xrightarrow{ut}$. We use the notation $t \in \sigma$ to indicate that the transition t occurs in the sequence σ and use $\sigma \leq \rho$ to indicate that σ is a prefix of the sequence ρ , i.e. $\exists \mu. \rho = \sigma \mu$.

3 Processes of place/transition systems

We now define two notions of a process of a net, modelling a run of the represented system on two levels of abstraction.

3.1 GR-processes

A (GR-)process is essentially a conflict-free, acyclic net together with a mapping function to the original net. It can be obtained by unwinding the original net, choosing one of the alternatives in case of conflict. The acyclic nature of the process gives rise to a notion of causality for transition firings in the original net via the mapping function. A conflict present in the original net is represented by the existence of multiple processes, each representing one possible way to decide the conflict.

Definition 5.

A pair $P = (\mathcal{N}, \pi)$ is a (*GR-*)*process* of a net $N = (S, T, F, M_0)$ iff

- $\mathcal{N} = (\mathcal{S}, \mathcal{T}, \mathcal{F}, \mathcal{M}_0)$ is a net, satisfying
 - $\forall s \in \mathcal{S}. |\bullet s| \leq 1 \geq |s\bullet| \wedge \mathcal{M}_0(s) = \begin{cases} 1 & \text{if } \bullet s = \emptyset \\ 0 & \text{otherwise,} \end{cases}$
 - \mathcal{F} is acyclic, i.e. $\forall x \in \mathcal{S} \cup \mathcal{T}. (x, x) \notin \mathcal{F}^+$, where \mathcal{F}^+ is the transitive closure of $\{(x, y) \mid \mathcal{F}(x, y) > 0\}$,
 - and $\{t \in \mathcal{T} \mid (t, u) \in \mathcal{F}^+\}$ is finite for all $u \in \mathcal{T}$.
- $\pi : \mathcal{S} \cup \mathcal{T} \rightarrow S \cup T$ is a function with $\pi(\mathcal{S}) \subseteq S$ and $\pi(\mathcal{T}) \subseteq T$, satisfying
 - $\pi(\mathcal{M}_0) = M_0$, i.e. $M_0(s) = |\pi^{-1}(s) \cap \mathcal{M}_0|$ for all $s \in S$, and
 - $\forall t \in \mathcal{T}, s \in S. F(s, \pi(t)) = |\pi^{-1}(s) \cap \bullet t| \wedge F(\pi(t), s) = |\pi^{-1}(s) \cap t\bullet|$, i.e. $\forall t \in \mathcal{T}. \pi(\bullet t) = \bullet \pi(t) \wedge \pi(t\bullet) = \pi(t)\bullet$.

P is called *finite* if \mathcal{T} is finite. The *end of* P is defined as $P^\circ = \{s \in \mathcal{S} \mid s\bullet = \emptyset\}$.

For example Fig. 1 gives a net and two of its GR-processes, in which each place and transition x is labelled $\pi(x)$. Let $\text{GR}(N)$ (resp. $\text{GR}_{fin}(N)$) denote the collection of (finite) GR-processes of N .

A process is not required to represent a completed run of the original net. It might just as well stop early. In those cases, some set of transitions can be added to the process such that another (larger) process is obtained. This corresponds to the system taking some more steps and gives rise to a natural order between processes.

Definition 6. Let $P = ((\mathcal{S}, \mathcal{T}, \mathcal{F}, \mathcal{M}_0), \pi)$ and $P' = ((\mathcal{S}', \mathcal{T}', \mathcal{F}', \mathcal{M}'_0), \pi')$ be two processes of the same net.

- P' is a *prefix* of P , notation $P' \leq P$, and P an *extension* of P' , iff $\mathcal{S}' \subseteq \mathcal{S}$, $\mathcal{T}' \subseteq \mathcal{T}$, $\mathcal{M}'_0 = \mathcal{M}_0$, $\mathcal{F}' = \mathcal{F} \upharpoonright (\mathcal{S}' \times \mathcal{T}' \cup \mathcal{T}' \times \mathcal{S}')$ and $\pi' = \pi \upharpoonright (\mathcal{S}' \cup \mathcal{T}')$.
- A process of a net is said to be *maximal* if it has no proper extension.

The requirements above imply that if $P' \leq P$, $(x, y) \in \mathcal{F}^+$ and $y \in \mathcal{S}' \cup \mathcal{T}'$ then $x \in \mathcal{S}' \cup \mathcal{T}'$. Conversely, any subset $\mathcal{T}' \subseteq \mathcal{T}$ satisfying $(t, u) \in \mathcal{F}^+ \wedge u \in \mathcal{T}' \Rightarrow t \in \mathcal{T}'$ uniquely determines a prefix of P .

In [Pet77,GSW80,GR83] processes were defined without requiring the third condition on \mathcal{N} from Definition 5. Goltz and Reisig [GR83] observed that certain processes did not correspond with runs of systems, and proposed to restrict the notion of a process to those that can be approximated by finite processes [GR83, end of Section 3]. This is the role of the third condition on \mathcal{N} in Definition 5; it is equivalent to requiring that each transition occurs in a finite prefix. In [Pet77,GSW80,GR83] only processes of finite nets were considered. For those processes, the requirement of *discreteness* proposed in [GR83] is equivalent with imposing the third condition on \mathcal{N} in Definition 5 [GR83, Theorem 2.14].

Two processes $P = (\mathcal{N}, \pi)$ and $P' = (\mathcal{N}', \pi')$ are *isomorphic*, notation $P \cong P'$, iff there exists an isomorphism ϕ from \mathcal{N} to \mathcal{N}' which respects the process mapping, i.e. $\pi = \pi' \circ \phi$. Here an *isomorphism* ϕ between two nets $\mathcal{N} = (\mathcal{S}, \mathcal{T}, \mathcal{F}, \mathcal{M}_0)$ and $\mathcal{N}' = (\mathcal{S}', \mathcal{T}', \mathcal{F}', \mathcal{M}'_0)$ is a bijection between their places and transitions such that $\mathcal{M}'_0(\phi(s)) = \mathcal{M}_0(s)$ for all $s \in \mathcal{S}$ and $\mathcal{F}'(\phi(x), \phi(y)) = \mathcal{F}(x, y)$ for all $x, y \in \mathcal{S} \cup \mathcal{T}$.

3.2 BD-processes

Next we formally introduce the swapping transformation and the resulting equivalence notion on GR-processes from [BD87].

Definition 7. Let $P = ((\mathcal{S}, \mathcal{T}, \mathcal{F}, \mathcal{M}_0), \pi)$ be a process and let $p, q \in \mathcal{S}$ with $(p, q) \notin \mathcal{F}^+ \cup (\mathcal{F}^+)^{-1}$ and $\pi(p) = \pi(q)$.

Then $\text{swap}(P, p, q)$ is defined as $((\mathcal{S}, \mathcal{T}, \mathcal{F}', \mathcal{M}_0), \pi)$ with

$$\mathcal{F}'(x, y) = \begin{cases} \mathcal{F}(q, y) & \text{iff } x = p, y \in \mathcal{T} \\ \mathcal{F}(p, y) & \text{iff } x = q, y \in \mathcal{T} \\ \mathcal{F}(x, y) & \text{otherwise.} \end{cases}$$

We refer to [BD87, GGS21] for an explanation of this definition and further examples. Here we only give the processes of Fig. 1 as being connected via swap.

Definition 8.

- Two processes P and Q of the same net are *one step swapping equivalent* ($P \equiv_1 Q$) iff $\text{swap}(P, p, q)$ is isomorphic to Q for some places p and q .
- We write \equiv_1^* for the reflexive and transitive closure of \equiv_1 .

In [BD87, Definition 7.8] swapping equivalence—denoted \equiv_1^∞ —is defined in terms of *reachable B-cuts*. In [GGS21] this definition was reformulated as follows, also introducing the associated preorder \sqsubseteq_1^∞ .

Definition 9. Let N be a net, and $P, Q \in \text{GR}(N)$.

Then $P \sqsubseteq_1^\infty Q$ iff

$$\forall P'' \in \text{GR}_{fn}(N), P'' \leq P. \exists P', Q' \in \text{GR}_{fn}(N). P'' \leq P' \equiv_1^* Q' \leq Q.$$

Moreover, $P \equiv_1^\infty Q$ iff $P \sqsubseteq_1^\infty Q \wedge Q \sqsubseteq_1^\infty P$.

In [GGS21] it is shown that \sqsubseteq_1^∞ is a preorder, and thus \equiv_1^∞ an equivalence relation on GR-processes. Trivially, \equiv_1^* is included in \equiv_1^∞ .

Definition 10.

We call a \equiv_1^∞ -equivalence class of GR-processes a *BD-process*.

4 Conflicts in place/transition systems

We recall the canonical notion of conflict introduced in [Gol86].

Definition 11. Let $N = (S, T, F, M_0)$ be a net and $M \in \mathbb{N}^S$.

- A finite, non-empty multiset $G \in \mathbb{N}^T$ is in (*semantic*) *conflict* in M iff $\neg M \xrightarrow{G} \wedge \forall t \in G. M \xrightarrow{G \setminus \{t\}}$.
- N is (*semantic*) *conflict-free* iff no finite, non-empty multiset $G \in \mathbb{N}^T$ is in semantic conflict in any M with $M_0 \rightarrow M$.
- N is *binary-conflict-free* iff no multiset $G \in \mathbb{N}^T$ with $|G| = 2$ is in semantic conflict in any M with $M_0 \rightarrow M$.

Thus, N is binary-conflict-free iff whenever two different transitions t and u are enabled at a reachable marking M , then also the step $\{t, u\}$ is enabled at M . The above concept of (semantic) conflict-freeness formalises the intuitive notion that there are no choices to resolve. In [GGs21] the above definition is compared with other notions of conflict and conflict-freeness that occur in the literature.

A finite multiset G of transitions has a *structural conflict* iff it contains two different transitions that share a preplace. We proposed in [GGs11a] a class of P/T systems where this structural definition of conflict matches the semantic definition of conflict as given above. We called this class of nets *structural conflict nets*. For a net to be a structural conflict net, we require that two transitions sharing a preplace will never occur both in one step.

Definition 12. Let $N = (S, T, F, M_0)$ be a net.

N is a *structural conflict net* iff $\forall t, u. (M_0 \rightarrow \{t, u\}) \Rightarrow \bullet t \cap \bullet u = \emptyset$.

Note that this excludes self-concurrency from the possible behaviours in a structural conflict net: as in our setting every transition has at least one preplace, $t = u$ implies $\bullet t \cap \bullet u \neq \emptyset$. Also note that in a structural conflict net a non-empty, finite multiset G is in conflict in a reachable marking M iff G is a set and two distinct transitions in G are in conflict in M . Hence a structural conflict net is conflict-free if and only if it is binary-conflict-free. Moreover, two transitions enabled in M are in (semantic) conflict iff they share a preplace.

5 Characterising BD-processes by firing sequences

In Section 3 a BD-process was defined as a \equiv_1^∞ -equivalence class of GR-processes; moreover the preorder \sqsubseteq_1^∞ on GR-processes induces a partial order on BD-processes, and hence a concept of a largest BD-process.

Best and Devillers [BD87] introduced an equivalence relation \equiv_0^∞ on the firing sequences of a countable net, such that the BD-processes are in a bijective correspondence with the \equiv_0^∞ -equivalence classes of firing sequences, called *FS-processes* in [GGs11a]. In this section we define a preorder \sqsubseteq_0^∞ on the firing sequences of a net, with kernel \equiv_0^∞ , that thus induces a partial order on FS-processes, and hence a concept of a largest FS-process. We show that the bijection

between BD-processes and FS-processes respects these orders, and therefore also the associated notion of a largest process. Thus a countable net has a largest BD-process iff it has a largest FS-process.

Our main result, that a countable P/T system without binary-conflict has a largest BD-process, can therefore be established in terms of FS-processes.

5.1 FS-processes

The behaviour of a net can be described not only by its processes, but also by its firing sequences. The imposed total order on transition firings abstracts from information on causal dependence, or concurrency, between transition firings. To retrieve this information we introduce an *adjacency* relation on firing sequences, recording which interchanges of transition occurrences are due to semantic independence of transitions. Hence adjacent firing sequences represent the same run of the net. We then define *FS-processes* in terms of the resulting equivalence classes of firing sequences. Adjacency is similar to the idea of Mazurkiewicz traces [Maz95], allowing to exchange concurrent transitions. However, it is based on the semantic notion of concurrency instead of the global syntactic independence relation of trace theory, similar as in the approach of generalising trace theory in [HKT95].

Definition 13. Let $N = (S, T, F, M_0)$ be a net, and $\sigma, \rho \in \text{FS}^\infty(N)$.

- σ and ρ are *adjacent*, $\sigma \equiv_0 \rho$, iff $\sigma = \sigma_1 t u \sigma_2$, $\rho = \sigma_1 u t \sigma_2$ and $M_0 \xrightarrow{\sigma_1} \{t, u\}$.
- We write \equiv_0^* for the reflexive and transitive closure of \equiv_0 .

Note that \equiv_0^* -related firing sequences contain the same multiset of transition occurrences. When writing $\sigma \equiv_0^* \rho$ we implicitly claim that $\sigma, \rho \in \text{FS}^\infty(N)$. Furthermore $\sigma \equiv_0^* \rho \wedge \sigma \mu \in \text{FS}^\infty(N)$ implies $\sigma \mu \equiv_0^* \rho \mu$ for all $\mu \in T^* \cup T^\omega$.

Lemma 1. Let $N = (S, T, F, M_0)$ be a net, let $\sigma_1 \equiv_0 \sigma_2 \leq \sigma_3$ for some $\sigma_1, \sigma_2 \in \text{FS}(N)$ and $\sigma_3 \in \text{FS}^\infty(N)$. Then there is a $\sigma' \in \text{FS}^\infty(N)$ with $\sigma_1 \leq \sigma' \equiv_0 \sigma_3$. Moreover, if $\sigma_3 \in \text{FS}(N)$ then $\sigma' \in \text{FS}(N)$.

Proof. We have that $\sigma_1 = \alpha t u \beta$, $\sigma_2 = \alpha u t \beta$, $M_0 \xrightarrow{\alpha} \{t, u\} M_1$ and $\sigma_3 = \sigma_2 \gamma$ for some $\alpha, \beta \in T^*$, $\gamma \in T^* \cup T^\omega$ and $M_1 \in \mathbb{N}^S$. Naturally then, we take $\sigma' = \alpha t u \beta \gamma$. From $M_0 \xrightarrow{\alpha} \{t, u\} M_1$ follows $M_0 \xrightarrow{\alpha t u} M_1$ and $M_0 \xrightarrow{\alpha u t} M_1$. From $\sigma_3 \in \text{FS}^\infty(N)$ follows additionally $M_1 \xrightarrow{\beta \gamma}$. Hence $M_0 \xrightarrow{\alpha t u} M_1 \xrightarrow{\beta \gamma}$ and $\sigma' \in \text{FS}^\infty(N)$. The case $\sigma_3 \in \text{FS}(N)$ follows similarly. That $\sigma_1 \leq \sigma' \equiv_0 \sigma_3$ holds trivially. \square

Corollary 1. Let $\sigma_1 \equiv_0^* \sigma_2 \leq \sigma_3$ for some $\sigma_1, \sigma_2 \in \text{FS}(N)$ and $\sigma_3 \in \text{FS}^\infty(N)$. Then there is a $\sigma' \in \text{FS}^\infty(N)$ with $\sigma_1 \leq \sigma' \equiv_0^* \sigma_3$. Moreover, if $\sigma_3 \in \text{FS}(N)$ then $\sigma' \in \text{FS}(N)$. \square

Lemma 2. Let $\sigma'' \in \text{FS}(N)$, $\rho \in \text{FS}^\infty(N)$. Then $\exists \rho^\dagger \in \text{FS}^\infty(N)$. $\sigma'' \leq \rho^\dagger \equiv_0^* \rho$ iff $\exists \sigma', \rho' \in \text{FS}(N)$. $\sigma'' \leq \sigma' \equiv_0^* \rho' \leq \rho$.

Proof. “If” follows by Corollary 1. For “only if” take ρ' to be the smallest prefix of ρ that contains all transitions interchanged between ρ and ρ^\dagger . \square

For firing sequences $\sigma, \rho \in \text{FS}^\infty(N)$, $\sigma \equiv_0^* \rho$ means that σ can be transformed into ρ by repeated exchange of two successive transitions that can fire concurrently. However, \equiv_0^* allows for only finitely many permutations. In [BD87] a relation \equiv_0^∞ on $\text{FS}^\infty(N)$ is defined that in some sense allows infinitely many permutations:

Definition 14. [BD87] Let N be a net, and $\sigma, \rho \in \text{FS}^\infty(N)$.

- Write $\sigma \sqsubseteq_n \rho$ when σ and ρ are equal or both have the same length $\geq n$ (possible infinite) and agree on the prefix of length n .
- Then $\sigma \equiv_0^\infty \rho$ iff $\forall n \in \mathbb{N}. \exists \sigma', \rho' \in \text{FS}^\infty(N). (\sigma \equiv_0^* \sigma' \sqsubseteq_n \rho \wedge \sigma \sqsubseteq_n \rho' \equiv_0^* \rho)$.

Observation 1 $\sigma \equiv_0^\infty \rho$ iff $\forall \rho'' \in \text{FS}(N), \rho'' \leq \rho. \exists \sigma' \in \text{FS}^\infty(N). \rho'' \leq \sigma' \equiv_0^* \sigma$ and $\forall \sigma'' \in \text{FS}(N), \sigma'' \leq \sigma. \exists \rho' \in \text{FS}^\infty(N). \sigma'' \leq \rho' \equiv_0^* \rho$.

Analogously, \sqsubseteq_0^∞ should be the binary relation on $\text{FS}^\infty(N)$ given by $\sigma \sqsubseteq_0^\infty \rho$ iff $\forall \sigma'' \in \text{FS}(N), \sigma'' \leq \sigma. \exists \rho' \in \text{FS}^\infty(N). \sigma'' \leq \rho' \equiv_0^* \rho$. Lemma 2 allows us to state the formal definition of \sqsubseteq_0^∞ as follows, which will be advantageous later on:

Definition 15. Let N be a net, and $\sigma, \rho \in \text{FS}^\infty(N)$.

Then $\sigma \sqsubseteq_0^\infty \rho$ iff

$$\forall \sigma'' \in \text{FS}(N), \sigma'' \leq \sigma. \exists \sigma', \rho' \in \text{FS}(N). \sigma'' \leq \sigma' \equiv_0^* \rho' \leq \rho.$$

Observation 2 $\sigma \equiv_0^\infty \rho$ iff $\sigma \sqsubseteq_0^\infty \rho$ and $\rho \sqsubseteq_0^\infty \sigma$.

Corollary 1, in combination with the transitivity of \leq and \equiv_0^* , implies the transitivity of \sqsubseteq_0^∞ . Moreover, by definition \sqsubseteq_0^∞ is reflexive.

Corollary 2. \sqsubseteq_0^∞ is a preorder on $\text{FS}^\infty(N)$. So \equiv_0^∞ is an equivalence relation.

Now an *FS-process* of a net N can be defined as an \equiv_0^∞ -equivalence class of possibly infinite firing sequences of N (elements of $\text{FS}^\infty(N)$). Since \equiv_0^∞ is the kernel of \sqsubseteq_0^∞ , the latter introduces a partial order on FS-processes, and hence a notion of a largest FS-process.

5.2 A bijection between FS-processes and countable BD-processes

We now recapitulate a result from [BD87], establishing a correspondence between the GR-processes of a countable net and its firing sequences.

Definition 16. [BD87] Let N be a net, $P = ((\mathcal{S}, \mathcal{T}, \mathcal{F}, \mathcal{M}_0), \pi) \in \text{GR}(N)$ and $\sigma = t_0 t_1 t_2 \dots \in \text{FS}^\infty(N)$. If σ is finite, let $I = \{i \mid \mathbb{N} \ni i < |\sigma|\}$; otherwise let $I = \mathbb{N}$.

P and σ are *compatible* iff there is a bijection $\text{pos} : \mathcal{T} \rightarrow I$ such that

1. $\forall t \in \mathcal{T}. \pi(t) = t_{\text{pos}(t)}$
2. $\forall t, t' \in \mathcal{T}. (t, t') \in \mathcal{F}^+ \Rightarrow \text{pos}(t) < \text{pos}(t')$.

Definition 17. [BD87] Let N be a net and $P \in \text{GR}(N)$.

$$\text{Lin}(P) := \{\sigma \mid \sigma \in \text{FS}^\infty(N) \text{ and } \sigma \text{ is compatible with } P\}.$$

Theorem 1. [BD87] Let $\sigma, \rho \in \text{FS}^\infty(N)$ and $P, Q \in \text{GR}(N)$ such that $\sigma \in \text{Lin}(P)$ and $\rho \in \text{Lin}(Q)$. Then $\sigma \equiv_0^\infty \rho$ iff $P \equiv_1^\infty Q$.

Definition 18. A net, or a GR-process, is *countable* iff it has countably many transitions. A BD-process is countable iff it is an equivalence class of countable GR-processes.

The last definition uses that if $P \equiv_1^\infty Q$, then P is countable iff Q is countable. By definition a finite net is countable. Since each transition in our nets has only finitely many pre- and postplaces, a countable net has only countably many arcs, and countably many places, at least when not counting isolated places, which are irrelevant.

Observation 3 Let N be a net.

For each firing sequence $\sigma \in \text{FS}^\infty(N)$ there exists a process $P \in \text{GR}(N)$ such that $\sigma \in \text{Lin}(P)$. Moreover, for each countable process $P \in \text{GR}(N)$ there exists a firing sequence $\sigma \in \text{FS}^\infty(N)$ such that $\sigma \in \text{Lin}(P)$, but for an uncountable process $P \in \text{GR}(N)$ there exists no firing sequence $\sigma \in \text{Lin}(P)$.

In [BD87] only countable nets are considered, and there Theorem 1, together with Observation 3, establishes a bijection between \equiv_0^∞ -equivalence classes of firing sequences and \equiv_1^∞ -equivalence classes of GR-processes, or, in our terminology, between FS-processes and BD-processes. When allowing uncountable nets, we obtain a bijection between FS-processes and countable BD-processes.

The following theorem says that this bijection preserves the order between FS- and BD-processes.

Theorem 2. Let $\sigma, \rho \in \text{FS}^\infty(N)$ and $P, Q \in \text{GR}(N)$ such that $\sigma \in \text{Lin}(P)$ and $\rho \in \text{Lin}(Q)$. Then $\sigma \sqsubseteq_0^\infty \rho$ iff $P \sqsubseteq_1^\infty Q$.

Together with Observation 3 this theorem establishes an order-preserving bijection between the FS-processes and the countable BD-processes of a net. Consequently, a countable net has a largest BD-process iff it has a largest FS-process.

Although the preorders \sqsubseteq_0^∞ and \sqsubseteq_1^∞ are not considered in [BD87], the proof of Theorem 1 in [BD87] can be adapted in a fairly straightforward way to yield a proof of Theorem 2 as well. A more detailed proof of Theorem 2, and thereby also of Theorem 1, using the notation of the present paper, is presented below.

5.3 This bijection preserves the order between processes

The next three lemmas say that if a process P is compatible with a firing sequence σ , then

- any finite extension of σ can be matched by a compatible extension of P ,
- any finite prefix of σ can be matched by a compatible prefix of P , and
- any finite extension of P can be matched by a compatible extension of σ .

Lemma 3. Let $P'' \in \text{GR}_{fin}(N)$, $\sigma'' \in \text{Lin}(P'')$ and $\sigma' \in \text{FS}(N)$ with $\sigma'' \leq \sigma'$. Then there is $P' \in \text{GR}_{fin}(N)$ with $\sigma' \in \text{Lin}(P')$ and $P'' \leq P'$.

Proof. We have that $\sigma''\alpha = \sigma'$ for some $\alpha \in T^*$. Using induction over the length of α we need to prove the claim only for $\sigma''t = \sigma'$ for arbitrary $t \in T$. Let $P'' = ((\mathcal{T}'', \mathcal{S}'', \mathcal{F}'', \mathcal{M}_0''), \pi'')$. From $\sigma' \in \text{FS}(N)$ follows $M_0 \xrightarrow{\sigma''} M_1 \xrightarrow{t}$. From $\sigma'' \in \text{Lin}(P'')$ we have that $M_1 = \pi''(P''^\circ)$ via Construction 3.9, Proposition 3.10, and Theorem 3.13 of [BD87]. Hence $\bullet t \subseteq M_1 = \pi''(P''^\circ)$. From P''° we select a set of (pre-)places A with $\pi''(A) = \bullet t$ and we create a set of fresh (post-)places B together with a function $\pi_B : B \rightarrow S$ such that $\pi_B(B) = t^\bullet$.

We define P' as $((\mathcal{T}', \mathcal{S}', \mathcal{F}', \mathcal{M}_0'), \pi') := ((\mathcal{T}'' \cup \{t'\}, \mathcal{S}'' \cup B, \mathcal{F}'' \cup \{(a, t', 1) \mid a \in A\} \cup \{(t', b, 1) \mid b \in B\}, \mathcal{M}_0''), \pi'' \cup \{(t', t)\} \cup \pi_B)$. We need to show that P' is a process of N , $P'' \leq P'$ and $\sigma' \in \text{Lin}(P')$.

“ P' is a process of N ”: $\forall s \in S'. |\bullet s| \leq 1$ as the only new entries in \mathcal{F}' which lead to places are for the new places from B , where it holds. $\forall s \in S'. 1 \geq |s^\bullet|$ as the only new entries in \mathcal{F}' which lead from places are for places s from P''° for which $|s^\bullet| = 0$ in P'' . Additionally $\mathcal{M}_0' = \mathcal{M}_0'$. \mathcal{F}' is acyclic as the new entries all contain t' and B is disjoint from \mathcal{S}'' . $\{t \in \mathcal{T}' \mid (t, u) \in \mathcal{F}'^+\}$ is finite for all $u \in \mathcal{T}'$ since \mathcal{T}'' and hence \mathcal{T}' is finite. $\pi'(\mathcal{M}_0') = \pi''(\mathcal{M}_0'') = M_0$ as B is distinct from \mathcal{S}'' , hence π_B contributes nothing to $\pi'(\mathcal{M}_0')$. Finally $\pi'(\bullet t') = \pi'(A) = \pi''(A) = \bullet t = \bullet \pi'(t')$ and $\pi'(t'^\bullet) = \pi'(B) = \pi_B(B) = t^\bullet = \pi'(t')^\bullet$. Hence P' is indeed a process.

“ $P'' \leq P'$ ”: As P' was construction from P'' using disjoint unions, this follows immediately.

“ $\sigma' \in \text{Lin}(P')$ ”: From $\sigma'' \in \text{Lin}(P'')$ we get a pos'' function. We define $\text{pos}' := \text{pos}'' \cup (t', |\sigma'| - 1)$. Checking Definition 16 we find $\pi'(t') = t$, which is the last transition in σ' . As $|\sigma'| - 1$ is one larger than the largest value of pos'' , pos' is a bijection, and since there is no $u' \in \mathcal{T}'$ with $(t', u') \in \mathcal{F}'^+$ we conclude that σ' is compatible with P' . \square

Lemma 4. Let $P \in \text{GR}(N)$, $\sigma \in \text{Lin}(P)$ and $\sigma'' \in \text{FS}(N)$ with $\sigma'' \leq \sigma$. Then there is $P'' \in \text{GR}_{fin}(N)$ with $\sigma'' \in \text{Lin}(P'')$ and $P'' \leq P$.

Proof. To be precise, let, in this proof only, $\bullet x, x^\bullet$ denote pre- respectively post-sets in N , $^\circ x, x^\circ$ denote pre- respectively post-sets in P , and $^* x, x^*$ denote pre- respectively post-sets in P'' .

We have that $\sigma''\alpha = \sigma$ for some $\alpha \in T^* \cup T^\omega$.

Let $P = ((S, \mathcal{T}, \mathcal{F}, \mathcal{M}_0), \pi)$. From $\sigma \in \text{Lin}(P)$ we get a bijection pos between \mathcal{T} and the elements of σ . As $\alpha \subseteq \sigma$, we can take the preimage $\phi := \text{pos}^{-1}(\alpha)$. We define $S'' := S \setminus \phi^\circ$ and $\mathcal{T}'' := \mathcal{T} \setminus \phi$ and take

$$P'' = ((S'', \mathcal{T}'', \mathcal{F} \upharpoonright (S'' \times \mathcal{T}'' \cup \mathcal{T}'' \times S''), \mathcal{M}_0), \pi \upharpoonright (S'' \cup \mathcal{T}'')).$$

We need to show that P'' is a finite process of N , $P'' \leq P$ and $\sigma'' \in \text{Lin}(P'')$.

“ P'' is a process of N ”: As elements were only removed from P and none of them were from \mathcal{M}_0 , all clauses of Definition 5 but the last follow. It remains

to be shown that for all $t \in \mathcal{T}''$ we have $\pi(*t) = \bullet\pi(t) \wedge \pi(t^*) = \pi(t)^\bullet$. By processhood of P we already have $\pi({}^\circ t) = \bullet\pi(t) \wedge \pi(t^\circ) = \pi(t)^\bullet$.

“ $\pi(*t) = \bullet\pi(t)$ ”: By $*t = {}^\circ t$, as follows: Take any $s \in {}^\circ t$. If we had $s \in t'^\circ$ for any $t' \in \phi$, then $\text{pos}(t) < |\sigma''|$ and $\text{pos}(t') \geq |\sigma''|$ (from their order in σ) but also $(t', t) \in \mathcal{F}^+$ and thus $\text{pos}(t') < \text{pos}(t)$ (from compatibility of P and σ). Hence we cannot have such a t' . Thus $s \notin \phi^\circ$, $s \in \mathcal{S}''$ and $s \in *t$.

“ $\pi(t^*) = \pi(t)^\bullet$ ”: By $t^* = t^\circ$, as follows: Take any $s \in t^\circ$. As $t \notin \phi$ and $|{}^\circ s| \leq 1$ for all $s \in \mathcal{S}$, we have $s \notin \phi^\circ$, $s \in \mathcal{S}''$ and $s \in t^*$.

“ P is finite”: This follows since $\mathcal{T}'' = \text{pos}^{-1}(\sigma'')$ and σ'' is finite.

“ $P'' \leq P$ ”: This follows immediately from the construction of P'' .

“ $\sigma'' \in \text{Lin}(P'')$ ”: Using $\text{pos} \upharpoonright \mathcal{T}''$ it follows that σ'' is compatible with P'' . \square

Lemma 5. Let $P'', P' \in \text{GR}_{\text{fin}}(N)$ with $P'' \leq P'$, and let $\sigma'' \in \text{Lin}(P'')$. Then there is a $\sigma_0 \in \text{Lin}(P')$ with $\sigma'' \leq \sigma_0$.

Proof. Let $P' = ((\mathcal{S}', \mathcal{T}', \mathcal{F}', \mathcal{M}'_0), \pi')$ and $P'' = ((\mathcal{S}'', \mathcal{T}'', \mathcal{F}'', \mathcal{M}''_0), \pi'')$. Applying induction over the number of transitions in \mathcal{T}' , we can restrict attention to the case where $\mathcal{T}' = \mathcal{T}'' \cup \{t'\}$ for one new transition t' .

We take $\sigma_0 = \sigma''\pi'(t')$ and need to show that $\sigma_0 \in \text{Lin}(P')$ (for by construction $\sigma'' \leq \sigma_0$). As $\sigma'' \in \text{Lin}(P'')$, it is compatible with P'' , so there exists a bijection $\text{pos}'' : \mathcal{T}'' \rightarrow \{0, \dots, |\sigma''| - 1\}$ as per Definition 16.

We define $\text{pos}_0 : \mathcal{T}' \rightarrow \{0, \dots, |\sigma_0| - 1\}$ as $\text{pos}_0(t) := \text{pos}''(t)$ iff $t \neq t'$ and $\text{pos}_0(t') := |\sigma_0| - 1 = |\sigma''|$ and need to show that σ_0 is compatible with P' :

1. For all $t'' \in \mathcal{T}''$ we have $\pi'(t'') = \pi''(t'') = t_{\text{pos}''(t'')} = t_{\text{pos}_0(t'')}$. Furthermore, by construction $t_{\text{pos}_0(t')} = t_{|\sigma_0|-1} = \pi'(t')$.
2. For all $u, u' \in \mathcal{T}'$ with $(u, u') \in \mathcal{F}'^+$ we need to show $\text{pos}_0(u) < \text{pos}_0(u')$. If $u \neq t' \neq u'$ then this follows from the compatibility of pos'' . For $u = t'$ there cannot be any $(u, u') \in \mathcal{F}'^+$ because t' was added last in an extension to a process. If $u' = t'$ we find that by definition $(t', t') \notin \mathcal{F}'^+$, and for all other possible u , $\text{pos}_0(u) = \text{pos}''(u) \leq |\sigma''| - 1 < |\sigma''| = \text{pos}_0(t')$.

Finally, we show that $\sigma_0 \in \text{FS}(N)$. Since $P'' \leq P'$ we have $\bullet t' \subseteq P''^\circ$. So $\bullet\pi'(t') = \pi'(\bullet t') \subseteq \pi'(P''^\circ) = \pi''(P''^\circ)$. Moreover, as $\sigma'' \in \text{Lin}(P'')$ we have $M_0 \xrightarrow{\sigma''} M$, where $M = \pi''(P''^\circ)$ via Construction 3.9, Proposition 3.10, and Theorem 3.13 of [BD87]. Hence $M \xrightarrow{\pi'(t')} \text{ and } \sigma_0 \in \text{FS}(N)$. \square

In line with the last three lemmas, one might expect that if a process P is compatible with a firing sequence σ , then any finite prefix of P can be matched by a compatible prefix of σ . This, however, is obviously false. Take for instance a process P consisting of two parallel transitions a and b , with the compatible firing sequence ab ; now the prefix of P containing only the transition b has no compatible prefix of ab . The following is our best approximation.

Lemma 6. Let $P'' \in \text{GR}_{\text{fin}}(N)$ and $P \in \text{GR}(N)$ with $P'' \leq P$, and let $\sigma \in \text{Lin}(P)$. Then there are $\sigma'' \in \text{Lin}(P'')$ and $\sigma_1, \sigma_2 \in \text{FS}(N)$ with $\sigma'' \leq \sigma_1 \equiv_0^* \sigma_2 \leq \sigma$.

Proof. Let $P = ((\mathcal{S}, \mathcal{T}, \mathcal{F}, \mathcal{M}_0), \pi)$ and $P'' = ((\mathcal{S}'', \mathcal{T}'', \mathcal{F}'', \mathcal{M}_0), \pi'')$. From $\sigma \in \text{Lin}(P)$ we have a bijection pos between \mathcal{T} and the indices of σ . Every finite process can be linearised to a firing sequence. Hence there exists some $\sigma'' \in \text{Lin}(P'')$. Thence we obtain a bijection $\text{pos}'' : \mathcal{T}'' \rightarrow \{0 \dots |\sigma''| - 1\}$. Since $P'' \leq P$ we find pos''^{-1} to be an injection $\{0 \dots |\sigma''| - 1\} \rightarrow \mathcal{T}$. As σ'' is finite, $j_{\max} := \max_{i \in \{0 \dots |\sigma''| - 1\}} \text{pos}(\text{pos}''^{-1}(i))$ exists. Let σ_2 be the prefix of σ of length $j_{\max} + 1$. Then $\text{pos}^{-1}(\sigma_2)$ selects a set of transitions from \mathcal{T} which together with the connecting places forms a prefix $P_2 \leq P$ (cf. Lemma 4). Let $P_2 = ((\mathcal{S}_2, \mathcal{T}_2, \mathcal{F}_2, \mathcal{M}_0), \pi_2)$. As σ_2 was chosen long enough, we find $\text{pos} \circ \text{pos}''^{-1}$ to be an injection from $\{0 \dots |\sigma''| - 1\}$ into $\{0 \dots |\sigma_2| - 1\}$ and hence $\text{pos}^{-1} \circ \text{pos} \circ \text{pos}''^{-1}$ to be an injection not only into \mathcal{T} but also into just \mathcal{T}_2 . Clearly then $\mathcal{T}'' \subseteq \mathcal{T}_2$. Also $\pi'' = \pi \upharpoonright (\mathcal{S}'' \cup \mathcal{T}'') = (\pi \upharpoonright (\mathcal{S}_2 \cup \mathcal{T}_2)) \upharpoonright (\mathcal{S}'' \cup \mathcal{T}'') = \pi_2 \upharpoonright (\mathcal{S}'' \cup \mathcal{T}'')$ which is to say, since both σ'' and σ_2 select some prefix from the beginning of the same P , they must have the same structure between shared transitions. Hence $P'' \leq P_2$. From Lemma 5 we then obtain a $\sigma_1 \in \text{Lin}(P_2)$ with $\sigma'' \leq \sigma_1$. As $\sigma_1 \in \text{Lin}(P_2)$ and $\sigma_2 \in \text{Lin}(P_2)$ we conclude, using Theorem 7.10 from [BD87], that $\sigma_1 \equiv_0^* \sigma_2$. \square

Besides these lemmas, we only need the following ‘‘finitary’’ version of Theorem 1.

Proposition 1. Let $\sigma, \rho \in \text{FS}(N)$ and $P, Q \in \text{GR}_{\text{fin}}(N)$ such that $\sigma \in \text{Lin}(P)$ and $\rho \in \text{Lin}(Q)$. Then $\sigma \equiv_0^* \rho$ iff $P \equiv_1^* Q$.

Proof. In [GGS11a] as Theorem 3 and an immediate conclusion from two theorems of [BD87].

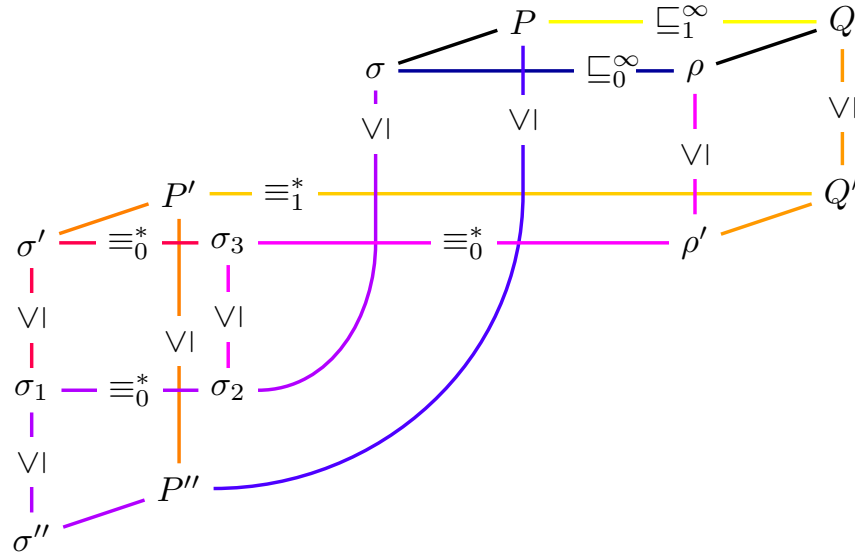

Proof of Theorem 2: ‘‘Only if’’: Suppose $\sigma \sqsubseteq_0^\infty \rho$. Let $P'' \in \text{GR}_{\text{fin}}(N)$ with $P'' \leq P$. It suffices to show that there are $P', Q' \in \text{GR}_{\text{fin}}(N)$ with $P'' \leq P' \equiv_1^* Q' \leq Q$. By Lemma 6 there are $\sigma'' \in \text{Lin}(P'')$ and $\sigma_1, \sigma_2 \in \text{FS}(N)$ with $\sigma'' \leq \sigma_1 \equiv_0^* \sigma_2 \leq \sigma$. By Definition 15, using that $\sigma \sqsubseteq_0^\infty \rho$ and $\sigma_2 \leq \sigma$, there are $\sigma_3, \rho' \in \text{FS}(N)$ with $\sigma_2 \leq \sigma_3 \equiv_0^* \rho' \leq \rho$. By Corollary 1, using that $\sigma_1 \equiv_0^* \sigma_2 \leq \sigma_3$, there is a $\sigma' \in \text{FS}(N)$ with $\sigma_1 \leq \sigma' \equiv_0^* \sigma_3$. Hence $\sigma'' \leq \sigma' \equiv_0^* \rho' \leq \rho$ by the transitivity of \leq and \equiv_0^* . By Lemma 3, using that $\sigma'' \leq \sigma'$ and $\sigma'' \in \text{Lin}(P'')$, there is

a $P' \in \text{GR}_{fin}(N)$ with $\sigma' \in \text{Lin}(P')$ and $P'' \leq P'$. By Lemma 4, substituting Q , ρ and ρ' for P , σ and σ'' , and using that $\rho' \leq \rho$ and $\rho \in \text{Lin}(Q)$, there is a $Q' \in \text{GR}_{fin}(N)$ with $\rho' \in \text{Lin}(Q')$ and $Q' \leq Q$. By Proposition 1, using that $\sigma' \in \text{Lin}(P')$, $\rho' \in \text{Lin}(Q')$ and $\sigma' \equiv_0^* \rho'$, we conclude $P' \equiv_1^* Q'$.

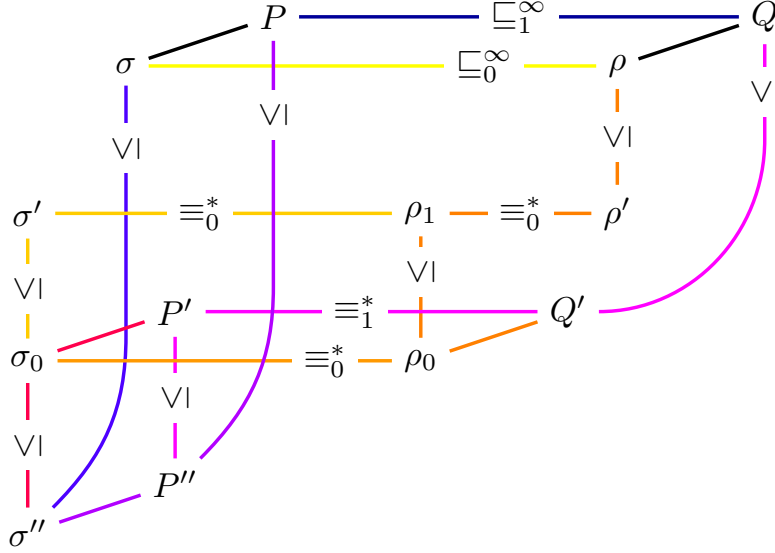

“If”: Suppose $P \sqsubseteq_1^\infty Q$. Let $\sigma'' \in \text{FS}(N)$ with $\sigma'' \leq \sigma$. It suffices to show that there are $\sigma', \rho' \in \text{FS}(N)$ with $\sigma'' \leq \sigma' \equiv_0^* \rho' \leq \rho$. By Lemma 4, using that $\sigma'' \leq \sigma \in \text{Lin}(P)$, there is a $P'' \in \text{GR}_{fin}(N)$ with $\sigma'' \in \text{Lin}(P'')$ and $P'' \leq P$. By Definition 9, using that $P \sqsubseteq_1^\infty Q$ and $P'' \leq P$, there are $P', Q' \in \text{GR}_{fin}(N)$ with $P'' \leq P' \equiv_1^* Q' \leq Q$. By Lemma 5, using that $P'' \leq P'$ and $\sigma'' \in \text{Lin}(P'')$, there is a $\sigma_0 \in \text{Lin}(P')$ with $\sigma'' \leq \sigma_0$. By Lemma 6, substituting Q', Q and ρ for P'', P and σ , and using that $Q' \leq Q$ and $\rho \in \text{Lin}(Q)$, there are $\rho_0 \in \text{Lin}(Q')$ and $\rho_1, \rho' \in \text{FS}(N)$ with $\rho_0 \leq \rho_1 \equiv_0^* \rho' \leq \rho$. By Proposition 1, using that $\sigma_0 \in \text{Lin}(P')$, $\rho_0 \in \text{Lin}(Q')$ and $P' \equiv_1^* Q'$, we obtain $\sigma_0 \equiv_0^* \rho_0$. By Corollary 1, using $\sigma_0 \equiv_0^* \rho_0 \leq \rho_1$, there is a $\sigma' \in \text{FS}(N)$ with $\sigma_0 \leq \sigma' \equiv_0^* \rho_1$. Hence $\sigma'' \leq \sigma' \equiv_0^* \rho' \leq \rho$ by the transitivity of \leq and \equiv_0^* . \square

6 A countable conflict-free net has a largest process

We now show that a countable conflict-free net has a largest process. As we have an order-preserving bijection between FS-process or BD-process, it does not matter which notion of process we use here. We prove an even stronger result, using binary-conflict-free instead of conflict-free. In preparation we need the following lemmas.

Lemma 7. Let $N = (S, T, F, M_0)$ be a binary-conflict-free net, $\sigma t, \sigma u \in \text{FS}(N)$ with $\sigma \in T^*$, $t, u \in T$, and $t \neq u$.

Then $\sigma t u, \sigma u t \in \text{FS}(N)$ and $\sigma t u \equiv_0^* \sigma u t$.

Proof. As we have unlabelled transitions, σ leads to a unique marking. From $M_0 \xrightarrow{\sigma t} \wedge M_0 \xrightarrow{\sigma u}$ we thus have that an M_1 exists with $M_0 \xrightarrow{\sigma} M_1 \wedge M_1 \xrightarrow{t} \wedge$

$M_1 \xrightarrow{u}$. Due to binary-conflict-freeness then also $M_1 \xrightarrow{\{t,u\}}$. Hence $M_0 \xrightarrow{\sigma} \xrightarrow{\{t,u\}}$, so $\sigma t u, \sigma u t \in \text{FS}(N)$ and $\sigma t u \equiv_0^* \sigma u t$. \square

Lemma 8. Let $N = (S, T, F, M_0)$ be a binary-conflict-free net, $\sigma t, \sigma \rho \in \text{FS}(N)$ with $t \in T$, $\sigma, \rho \in T^*$, and $t \notin \rho$.

Then $\sigma t \rho, \sigma \rho t \in \text{FS}(N)$ and $\sigma t \rho \equiv_0^* \sigma \rho t$.

Proof. Via induction on the length of ρ .

If $\rho = \varepsilon$, $\sigma t \in \text{FS}(N)$ trivially implies $\sigma \varepsilon t, \sigma t \varepsilon \in \text{FS}(N)$ and $\sigma \varepsilon t \equiv_0^* \sigma t \varepsilon$.

For the induction step take $\rho := u\mu$ (thus $u \neq t$). With $\sigma t, \sigma u \in \text{FS}(N)$ and Lemma 7 also $\sigma u t \in \text{FS}(N)$ and $\sigma t u \equiv_0^* \sigma u t$. Together with $\sigma u \mu \in \text{FS}(N)$, the induction assumption then gives us $\sigma u t \mu \in \text{FS}(N)$ and $\sigma u t \mu \equiv_0^* \sigma u \mu t = \sigma \rho t$. With $\sigma u t \equiv_0^* \sigma t u$ also $\sigma u t \mu \equiv_0^* \sigma t u \mu = \sigma t \rho$ and $\sigma \rho t, \sigma t \rho \in \text{FS}(N)$. \square

Lemma 9. Let $N = (S, T, F, M_0)$ be a binary-conflict-free net, $\sigma, \rho_1, \rho_2 \in T^*$, $t \in T$, $t \notin \rho_1$.

If $\sigma t \in \text{FS}(N) \wedge \sigma \rho_1 t \rho_2 \in \text{FS}(N)$ then $\sigma t \rho_1 \rho_2 \in \text{FS}(N) \wedge \sigma t \rho_1 \rho_2 \equiv_0^* \sigma \rho_1 t \rho_2$.

Proof. Applying Lemma 8 with $\sigma t \in \text{FS}(N) \wedge \sigma \rho_1 \in \text{FS}(N)$ we get $\sigma t \rho_1 \in \text{FS}(N) \wedge \sigma t \rho_1 \equiv_0^* \sigma \rho_1 t$. Since $\sigma \rho_1 t \rho_2 \in \text{FS}(N)$ the latter yields $\sigma t \rho_1 \rho_2 \equiv_0^* \sigma \rho_1 t \rho_2$ and thus $\sigma t \rho_1 \rho_2 \in \text{FS}(N)$. \square

Lemma 10. Let N be a binary-conflict-free net.

If $\sigma, \sigma' \in \text{FS}(N)$ then $\exists \mu, \mu'. \sigma \mu \in \text{FS}(N) \wedge \sigma' \mu' \in \text{FS}(N) \wedge \sigma \mu \equiv_0^* \sigma' \mu'$.

Proof. Via induction on the length of σ .

If $\sigma = \varepsilon$ we take $\mu = \sigma'$ and $\mu' = \varepsilon$.

For the induction step we start with

$$\sigma, \sigma' \in \text{FS}(N) \Rightarrow \exists \mu, \mu'. \sigma \mu \in \text{FS}(N) \wedge \sigma' \mu' \in \text{FS}(N) \wedge \sigma \mu \equiv_0^* \sigma' \mu'$$

and need to show that

$$\sigma t, \sigma' \in \text{FS}(N) \Rightarrow \exists \bar{\mu}, \bar{\mu}'. \sigma t \bar{\mu} \in \text{FS}(N) \wedge \sigma' \bar{\mu}' \in \text{FS}(N) \wedge \sigma t \bar{\mu} \equiv_0^* \sigma' \bar{\mu}' .$$

If $t \in \mu$, μ must be of the form $\mu_1 t \mu_2$ with $t \notin \mu_1$. We then take $\bar{\mu} := \mu_1 \mu_2$ and $\bar{\mu}' := \mu'$. By Lemma 9 we find $\sigma t \mu_1 \mu_2 \in \text{FS}(N)$, i.e. $\sigma t \bar{\mu} \in \text{FS}(N)$. By the induction assumption $\sigma' \bar{\mu}' \in \text{FS}(N)$. Per Lemma 9 $\sigma t \bar{\mu} = \sigma t \mu_1 \mu_2 \equiv_0^* \sigma \mu_1 t \mu_2 = \sigma \mu$. From the induction assumption we obtain $\sigma \mu \equiv_0^* \sigma' \mu' = \sigma' \bar{\mu}'$.

If $t \notin \mu$, we take $\bar{\mu} := \mu$ and $\bar{\mu}' := \mu' t$. By Lemma 8 we find that $\sigma t \mu, \sigma \mu t \in \text{FS}(N)$, i.e. also $\sigma t \bar{\mu} \in \text{FS}(N)$. From $\sigma \mu t \in \text{FS}(N)$ and $\sigma \mu \equiv_0^* \sigma' \mu'$ follows that $\sigma' \mu' t \in \text{FS}(N)$, i.e. $\sigma' \bar{\mu}' \in \text{FS}(N)$. Also by Lemma 8 we find $\sigma t \bar{\mu} = \sigma t \mu \equiv_0^* \sigma \mu t$. From the induction assumption we obtain $\sigma \mu t \equiv_0^* \sigma' \mu' t = \sigma' \bar{\mu}'$. \square

Theorem 3. Let $N = (S, T, F, M_0)$ be a countable, binary-conflict-free net.

Then N has a \sqsubseteq_0^∞ -largest FS-process.

Proof. Since N is countable, so is the set $\text{FS}(N)$ of its finite firing sequences. Enumerate its elements as $\sigma_1, \sigma_2, \dots$

By induction, we will construct two sequence ρ_1, ρ_2, \dots and $\sigma'_1, \sigma'_2, \dots$ of finite firing sequences, such that, for all $i > 0$, (1) $\rho_i \leq \rho_{i+1}$, and (2) $\sigma_i \leq \sigma'_i \equiv_0^* \rho_i$. Now let $\rho \in \text{FS}^\infty(N)$ be the limit of all the ρ_i . Then trivially $\sigma \sqsubseteq_0^\infty \rho$ for any $\sigma \in \text{FS}^\infty(N)$, so that ρ is the \sqsubseteq_0^∞ -largest FS-process of N .

Induction base: Take $\rho_1 := \sigma'_1 := \sigma_1$.

Induction step: Given ρ_i , by Lemma 10 there are $\mu, \mu' \in T^*$ such that $\rho_i \mu$ and $\sigma_{i+1} \mu' \in \text{FS}(N)$ and $\rho_i \mu \equiv_0^* \sigma_{i+1} \mu'$. Take $\rho_{i+1} = \rho_i \mu$ and $\sigma'_{i+1} := \sigma_{i+1} \mu'$. \square

Corollary 3. A countable and binary-conflict-free net N has exactly one \sqsubseteq_1^∞ -largest BD-process.

Proof. By Theorem 3, N has a \sqsubseteq_0^∞ -largest FS-process. Take any representative firing sequence σ thereof. By Observation 3 there is a $P \in \text{GR}(N)$ with $\sigma \in \text{Lin}(P)$.

Now take any $Q \in \text{GR}(N)$. As N is countable, so is Q . From Observation 3 thus exists $\rho \in \text{Lin}(Q)$. As σ comes from the largest FS-process, $\rho \sqsubseteq_0^\infty \sigma$. By Theorem 2 then $Q \sqsubseteq_1^\infty P$.

Thus P is a representative of the largest BD-process of N . \square

Corollary 3 does not hold for uncountable nets, as witnessed by the counterexample in Fig. 2. This binary-conflict-free net N has a transition t for each real number $t \in \mathbb{R}$. Each such transition has a private preplace s_t with $M_0(s_t) = 1$ and $F(s_t, t) = 1$, which ensures that t can fire only once. Furthermore there is one shared place s with $M_0(s) = 2$ and a loop $F(s, t) = F(t, s) = 1$ for each transition t . There are no other places, transitions or arcs besides the ones mentioned above.

Each GR-process of N , and hence also each BD-process P , has only countably many transitions. Moreover, any two GR-processes firing the same countable set of transitions of N are swapping equivalent. Thus a BD-process is fully determined by a countable set of reals, and the \sqsubseteq_1^∞ -order between BD-processes corresponds with set-inclusion. It follows that N does not have a \sqsubseteq_1^∞ -largest BD-process.

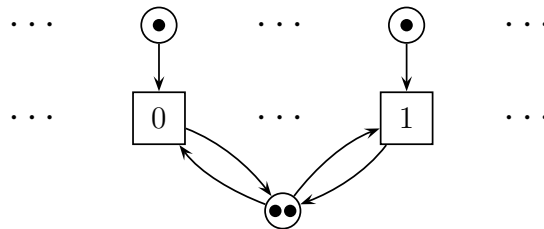

Fig. 2. A net without a \sqsubseteq_1^∞ -largest BD-process.

7 Conclusion

Best and Devillers [BD87] established a bijective correspondence between BD-processes and FS-processes (our terminology) of countable place/transition systems. A BD-process is an equivalence class of Goltz-Reisig processes under the notion of swapping equivalence proposed in [BD87]. An FS-process is an equivalence class of firing sequences under a related notion of equivalence also proposed in [BD87]. Here we considered natural partial orders on BD-processes as well as on FS-processes, and showed that the bijective correspondence between BD- and FS-processes preserves these orders, and hence the notion of a largest process.

Moreover, we showed that a countable place/transition system without binary conflicts has a largest FS-process, and hence a largest BD-process. By means of a counterexample we indicated that this result does not extend to uncountable nets.

We showed in [GGs11a] that the reverse direction, that a place/transition system with a largest BD-process is binary-conflict-free, holds for a large class of Petri nets, called structural conflict nets, which include the safe nets. The example from Fig. 1 shows it does not hold for arbitrary countable place/transition systems. This system has a largest BD-process but does have a binary conflict: after the a -transition, both b and c are possible, but the step $\{b, c\}$ is not.

The question whether an uncountable net without (any) conflict always has a largest BD-process is left open.

References

- [BD87] E. Best & R.R. Devillers (1987): *Sequential and Concurrent Behaviour in Petri Net Theory*. *Theoretical Computer Science* 55(1), pp. 87–136, doi:10.1016/0304-3975(87)90090-9. See also: E. Best and R.R. Devillers (1987): *Interleaving and Partial Orders in Concurrency: A Formal Comparison*. In M. Wirsing, editor: *Formal Description of Programming Concepts III*, 1987, pp. 299–321, North-Holland.
- [DMM89] P. Degano, J. Meseguer & U. Montanari (1989): *Axiomatizing Net Computations and Processes*. In: *Proceedings LICS'89, IEEE*, pp. 175–185. See also P. Degano, J. Meseguer & U. Montanari (1996): *Axiomatizing the Algebra of Net Computations and Processes*. *Acta Informatica* 33(5), pp. 641–667, doi:10.1007/BF03036469.
- [GGs11a] R.J. van Glabbeek, U. Goltz & J.-W. Schicke (2011): *Abstract Processes of Place/Transition Systems*. *Information Processing Letters* 111(13), pp. 626 – 633, doi:10.1016/j.ip1.2011.03.013.
- [GGs11b] R.J. van Glabbeek, U. Goltz & J.-W. Schicke (2011): *On Causal Semantics of Petri Nets*. Informatik Bericht Nr. 2011-06, Institut für Programmierung und Reaktive Systeme, TU Braunschweig, Germany. Available at <http://theory.stanford.edu/~rvg/abstracts.html#90>. Extended abstract in J.-P. Katoen and B. König, editors: *Proceedings CONCUR'11, LNCS 6901*, Springer, 2011, pp. 43–59.
- [GGs21] R.J. van Glabbeek, U. Goltz & J.-W. Schicke-Uffmann (2021): *Abstract Processes and Conflicts in General Place/Transition Systems*. To appear in *Information and Computation*, doi: [10.1016/j.ic2021.104706](https://doi.org/10.1016/j.ic2021.104706).

- [Gol86] U. Goltz (1986): *How Many Transitions may be in Conflict?* *Petri Net Newsletter* 25, pp. 4–9. Available at <http://theory.stanford.edu/~rvg/HowManyTransitionsMayBeInConflict.pdf>.
- [GR83] U. Goltz & W. Reisig (1983): *The Non-Sequential Behaviour of Petri Nets.* *Information and Control* 57(2-3), pp. 125–147, doi:10.1016/S0019-9958(83)80040-0.
- [GSW80] H.J. Genrich & E. Stankiewicz-Wiechno (1980): *A Dictionary of Some Basic Notions of Net Theory.* In W. Brauer, editor: *Advanced Course: Net Theory and Applications*, LNCS 84, Springer, pp. 519–531, doi:10.1007/3-540-10001-6_39.
- [HKT95] P.W. Hoogers, H.C.M. Kleijn & P.S. Thiagarajan (1995): *A Trace Semantics for Petri Nets.* *Information and Computation* 117, pp. 98–114, doi:10.1006/inco.1995.1032.
- [Maz95] A.W. Mazurkiewicz (1995): *Introduction to Trace Theory.* In V. Diekert & G. Rozenberg, editors: *The Book of Traces*, World Scientific, pp. 3–41.
- [Och89] Edward Ochmański (1989): Personal communication.
- [Pet77] C.A. Petri (1977): *Non-sequential Processes.* GMD-ISF Report 77.05, GMD.